



Scientific Laboratory Equipment, Supplied Worldwide

## Product Catalog

## About us

Formerly known as Scientific Equipment & Services, we have the pleasure of introducing ourselves as a reputed manufacturers of complete laboratory experiments and precision measuring instruments for BS and MS laboratories of Physics and Electronics.

For the last 39 years, we have been catering to the needs of over 1200 institutions in over 32 countries. We, while orienting ourselves to the need of laboratories have been trying our best to develop and introduce progressively more advanced laboratory experiments and general-purpose measuring instruments.

Our strict quality control ensures uncompromising quality of our instruments, low overheads and direct sales to the customers have enabled us to keep our rates very affordable.

The product catalogue highlights some of our manufacturing activities. The technical specifications given here are meant to give an accurate statement of performance of instruments manufactured by us.

## Note of thanks

We at *(Formerly Scientific Equipment & Services)*, are grateful to the staff of IIT- , particularly Professor K.C. Mittal, and Professor M.K. Srivastava, for their tremendous support all through these years by giving innovative suggestions and constructive criticism thereby helping in constantly adding new products and improving the existing ones.

## Warranty

All our products are manufactured under high level of quality control. They are warranted free from defects for a period of one year from the date of purchase. We will repair or replace as find suitable, any piece of defective equipment during this period. Even after this period after sales service is undertaken at very nominal charges.

## Specifications

Specifications of all products are subject to change without notice. reserves the right to make improvements to the products without incurring any obligation to incorporate these changes in products previously sold.

## Power requirement

# Index

1.	Digital D.C. Microvoltmeter: DMV-001 & DMV-001-C2	7
2.	Digital Nanometer: DNM-121 & DNM-121-C2	9
3.	Digital Picoammeter: DPM-111	11
4.	Digital Picoammeter: DPM-111-C2	12
5.	High Voltage Power Supply: EHT-11 & EHT-11-C1	14
6.	True RMS A.C. Millivoltmeter: ACM-102/ACM-103	15
7.	Electromagnet & Power Supply: EMU-75 & DPS-175M	16
8.	Electromagnet & Power Supply: EMU-75 & DPS-175-C2	18
9.	Electromagnet & Power Supply: DPS-175-BPC	20
10.	Electromagnet & Power Supply: EMU-50	22
11.	Constant Current Power Supply: DPS-50 & DPS-50-C1	23
12.	Digital Gaussmeter: DGM-202 & DGM-202-C1	24
13.	Digital Gaussmeter: DGM-204 & DGM-204-C2	25
14.	Hand Held Gaussmeter: DGM-HH-02	27
15.	Hand Held Gaussmeter: DGM-HH-02C	28
16.	Teslameter: TM-400	29
17.	PID Controlled Oven: PID-TZN/ PID-TZN-CT	30
18.	PID Controlled Oven: PID-TZ-C1	31
19.	Travelling Microscope: TVM-02	32
20.	Travelling Microscope: TVM-03	33
21.	Regulated Power Supply: PS-12	34
22.	DDS Function Generator: JDS-6600	35
23.	Magnetic Field Measurement Apparatus: MFM-01	37
24.	Study of Dielectric Constant and Curie Temperature of Ferroelectric Ceramics: DEC-01	38
25.	Frequency Dependence of Dielectric Constant: FDD-01	40
26.	Dielectric Constant of Liquids: DCL-01	42
27.	Dielectric Constant of Solids & Liquids: DSL-01	43
28.	Dielectric Measurement Setup: DEC-600	44

# Index

29.	Zeeman Effect Experiment: ZEX-01	46
30.	Millikan's Oil Drop Experiment: MOD-01 (LED TV)	47
31.	Planck's Constant by Photoelectric Effect: PC-101	49
32.	Determination of Planck's Constant by means of LED's: PCA-01	51
33.	Frank Hertz Experiment: FH-3001	53
34.	Ionisation Potential Set-up: IP-01	55
35.	Resistivity of Semiconductors by Four Probe Method at Different Temperatures and Determination of the Band-gap: DFP-02 (Basic :)	57
36.	Resistivity of Semiconductors by Four Probe Method at Different Temperatures and Determination of the Band-gap: DFP-03 (Advance :)	59
37.	Four Probe Set-Up for measuring the resistivity of very low to highly resistive thin sheet samples at different temperatures: DFP-RM-200N (Research :)	61
38.	Four Probe Set-Up for measuring the resistivity of very low to highly resistive thin sheet samples at different temperatures: DFP-RM-200NC (Research)	64
39.	Four Probe measurement set-up for wide range of resistivity samples from 170°C to 200°C temperatures: DFP-LHN	67
40.	Four Probe measurement set-up for wide range of resistivity samples from -190°C to 200°C temperatures: DFP-LHC	70
41.	Four Probe Set-up for Mapping the Resistivity of Large Samples: FP-01	73
42.	Four Probe Set-up for Mapping the Resistivity of Large Samples: FP-01C	76
43.	Van der Pauw Experiment for measuring both resistivity and hall coefficients of given semiconductor samples: VDX-01	79
44.	Measurement of Magnetoresistance of Semiconductors: MRX-01	81
45.	Measurement of Magnetoresistance in Different Samples: MRX-RMN	83
46.	Measurement of Magnetoresistance in Different Samples: MRX-RMC	86
47.	Two Probe Method for Resistivity Measurement of Insulators: TPX-200N (upto $10^{13}\Omega\cdot\text{cm.}$ ) at Different Temperatures	89
48.	Two Probe Method for Resistivity Measurement of Insulators: TPX-200C (upto $10^{13}\Omega\cdot\text{cm.}$ ) at Different Temperatures with USB based computer interface	91

# Index

50.	High Temperature Two Probe Set-up: TPX-600C with USB based computer interface facility	94
51.	Electron Spin Resonance Spectrometer: ESR-105	96
52.	NMR Experiment: NMR-01	98
53.	Study of Thermoluminescence of F-centres in Alkali Halide Crystals: TLX-02	100
54.	Thermoluminescence Irradiation Unit: TIU-02	102
55.	Hall Effect Experiment: HEX-21	103
56.	Hall Effect Experiment: HEX-21C	105
57.	Hall Effect Experiment: HEX-RM-150/ HEX-RM-150C	107
58.	Hall Effect in Metals: HEM-01	110
59.	Dependence of Hall Coefficient on Temperature: HEX-33	112
60.	Dependence of Hall Coefficient on Temperature: HEX-33C	114
61.	Apparatus for the Measurement of Susceptibility of Paramagnetic Solution by Quinck's Tube Method: QTX-01	116
62.	Apparatus for the Measurement of Susceptibility of Solids by Gouy's Method: GMX-01 (with EMU-75 & DPS-175M)	118
63.	Apparatus for the Measurement of Susceptibility of Solids by Gouy's Method: GMX-02 (50) (with EMU-50T & DPS-50)	120
64.	Apparatus for the Measurement of Susceptibility of Solids by Gouy's Method: GMX-02 (75) (with EMU-75T & DPS-175)	122
65.	Magnetic Hysteresis Loop Tracer: HLT-111	123
66.	Magnetic Hysteresis Loop Tracer: HLT-111C	125
67.	Ferroelectric PE Loop Tracer: PEL-01C	127
68.	Study of energy band-gap and diffusion potential of P-N Junctions: PN-01	129
69.	Diode Characteristics & Boltzman Constant: DCBC-01	131
70.	Characteristics of Photo Devices: PD-01	132
71.	Study of a Transistor Amplifier (RC Coupled) Cum-Feed Back Amplifier: RC-01	133
72.	Study of Multivibrators: MV-01	134
73.	Study of Characteristics of Semiconductors Diodes Si: Ge: Zener & LED: D-1	135
74.	Study of Hybrid Parameters of Transistors: HP-01	136

# Index

75.	Study of a Solid State Power Supply: SSPS-02	137
76.	Study of Modulation & Demodulation with Built-in Carrier Frequency (Solid State): MD-01	138
77.	Study of a Basic Operational Amplifier Type-741: 741-01	139
78.	Study of Op Amp 741 Applications: 741-03	140
79.	Signal Generation Applications of Op Amp 741: 741-05	141
80.	Study of Op Amp Based LC Oscillators: 741-07	142
81.	Study of Active Filters: Type AF-01	143
82.	Study of Astable & Monostable Multivibrators using Timer IC: 555	144
83.	Study of an Integrated Circuit Regulator: 723	145
84.	Vibrating Sample Magnetometer: VSM-1000	146

# DMV-001

## Digital Microvoltmeter

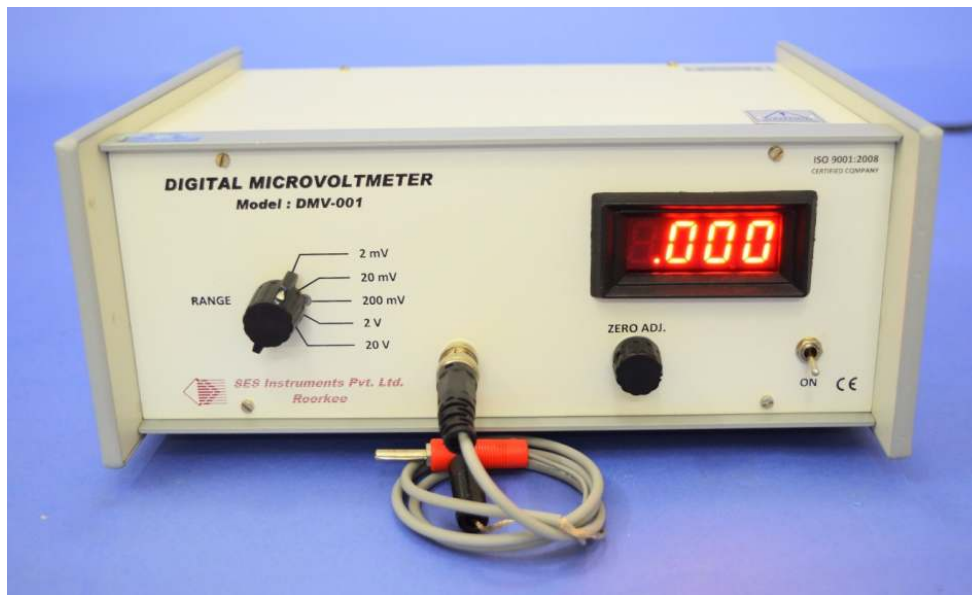

- Very low temperature drift
- Low dc input bias current-10pA
- Measures voltage down to 1 $\mu$ V
- Automatic polarity indication
- Built-in polarity indication
- Recorder facility (optional)

### Introduction

Digital Microvoltmeter, DMV-001 is a very versatile multipurpose instrument for the measurement of low dc voltage. It has 5 decade ranges from 1mV to 10V with 100% over-ranging. For better accuracy and convenience, readings are directly obtained on 3½ digit DPM (Digital Panel Meter). This instrument uses a very well designed chopper stabilized IC amplifier. This amplifier offers exceptionally low offset voltage and input bias parameters, combined with excellent speed characteristics. Filter circuit is provided to reduce the line pickups of 50Hz. All internal power supplies are IC regulated.

### Applications

- DC voltage measurements from high impedance sources; output of photomultiplier tubes, photo cells, radiation detector etc.
- Very low voltage measurement, direct measurement of thermocouple output to read temperatures with a resolution of 1/40th of a degree (Chromel-Alumel).
- General purpose laboratory instrument for voltages upto 19.99VDC. (Hall Effect, Four Probe, Thermoluminescence, Transistor and Diode characteristics etc.).

### Specification

Range	: 1mV, 10mV, 100mV, 1V & 10V with 100% over-ranging.
Resolution	: 1 $\mu$ V
Accuracy	: $\pm 0.2\%$ $\pm 1$ digit
Stability	: Within $\pm 1$ digit
Input Impedance	: >1000M $\Omega$ (10M $\Omega$ on 10V range)
Display	: 3½ digit, 7 segment LED with autopolarity and decimal indication
Interfacing	: USB (in DMV-001-C2 only)
Software	: DACC and CAMM, both Window compatible
Power Supply	: 220V $\pm 10\%$ , 50Hz
Weight	: 2.5Kg
Dimensions	: 245mm X 280mm X 120mm

# DMV-001

## Digital Microvoltmeter

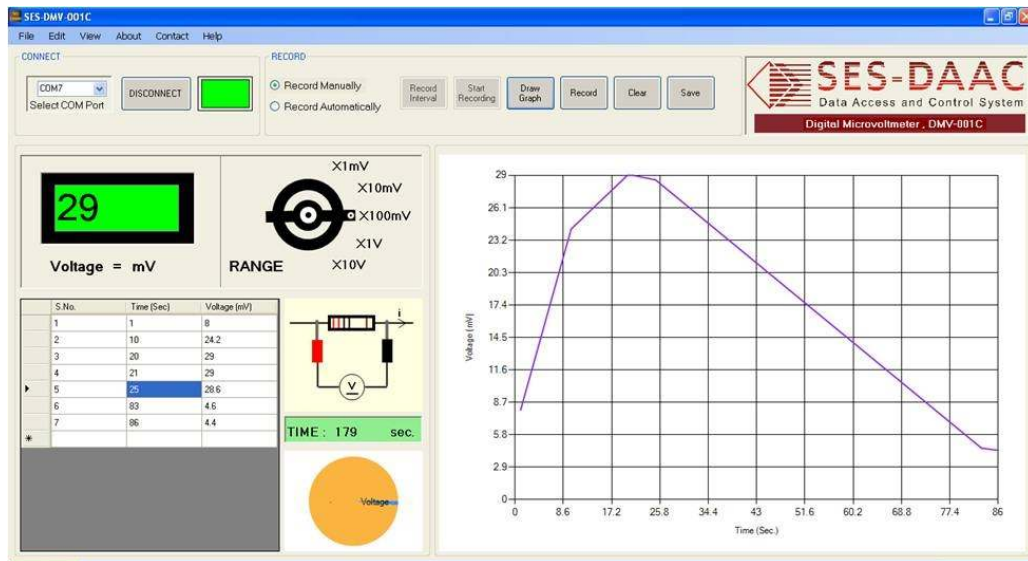

### Computer Interface, SES-DAAC (In DMV-001-C2 only)

The unit can be connected directly to a PC through a USB. SES-Data Access And Control is a built-in interface which gives user an option to store a value as displayed on the meter and tabulate it by the click of a button on the screen. Alternatively the data may be automatically entered into a table at user selectable interval. An 'END' button on the screen terminates the automatic tabulation. The data stored in the table may then be displayed as a graph on the screen and may also be stored in an excel file for further processing. The software supplied with the unit is menu driven and is simple to operate.

### SES-CAMM Compatible (In DMV-001-C2 only)

This unit can also be connected to a PC through an interface module SES-CAMM to record the voltage values. SES-CAMM is a computer aided measurement module for connecting multiple subunits of experiments, such as Four Probe Setup, to same interface on a computer. This feature is particularly useful in making this model compatible with computerized versions of complete experiments from our company.



# DNM-121

## Digital Nanoammeter



- Measures current down to 100pA
- All solid state and IC design
- Accepts either polarity of input current
- Build-in computer interface

### Introduction

Digital Nanoammeter, DNM-121, a rugged and low cost instrument, is a product of extensive R&D using high input impedance integrated circuits. It has 4 decade ranges with 100% over-ranging. The unit is suitable for current measurement in the range of 100pA to 200pA. For the ease, readings are directly obtained on a 3 1/2 digit DPM. The instrument is capable of accepting either polarity of the input current.

The very low leakage current of the input stage combined with the high linearity fast response due to high negative feedback enables accurate and easily reproducible measurements. The instrument uses a FET input operational amplifier that offers the very low input bias current, low offset voltage, low drift and noise. These characteristics have been fully utilized in the present Nanoammeter. This operational amplifier is used in low level current to voltage configuration.

### Applications

- To measure current from photomultiplier tubes, photometer etc.
- Leakage currents in solid state devices. FET gate and tube grid voltages without loading errors.
- Current through very high resistance in conjunction with a power supply.
- Potentials across semiconductors, piezoelectric systems & pH electrodes.

### Specifications

Range	: 100nA, 1µA, 10µA, 100µA with 100% over-ranging
Accuracy	: 0.2% for all ranges
Resolution	: 0.1nA
Input Impedance	: 25Ω, 2.5Ω, 0.25Ω, 0.025Ω
Display	: 3 1/2 digit 7 segment LED (12.5mm height) with auto polarity and decimal indication
Input	: Through BNC connector
Interfacing	: USB (In DNM-121-C2 only)
Software	: DACC and CMM, both Window compatible (In DNM-121-C2 only)
Power Supply	: 220V ±10%, 50Hz
Weight	: 2.5Kg

# DNM-121

## Digital Nanoammeter

Page-2

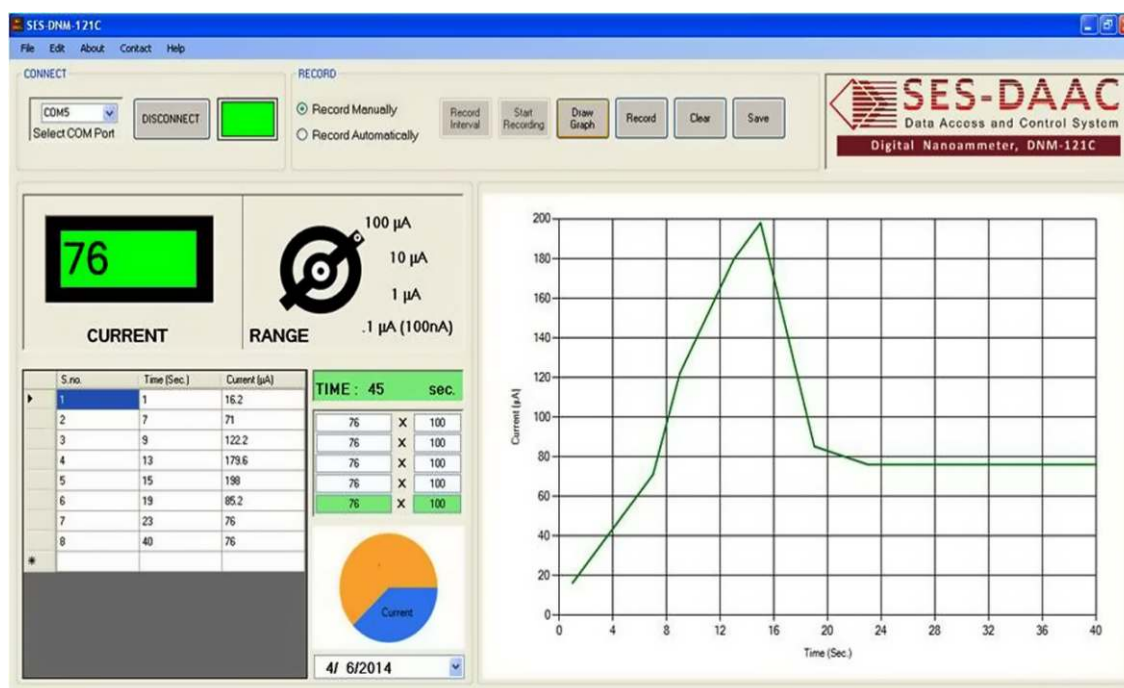

### Computer Interface, SES-DAAC (In DNM-121-C2 only)

The unit can be connected directly to a PC through an USB. SES-Data Access And Control is a built-in interface which gives user an option to store a value as displayed on the meter and tabulate it by the click of a button on the screen. Alternatively the data may be automatically entered into a table at user selectable interval. An 'END' button on the screen terminates the automatic tabulation. The data stored in the table may then be displayed as a graph on the screen and may also be stored in an excel file for further processing. The software supplied with the unit is menu driven and is simple to operate.

### SES-CAMM Compatible (In DNM-121-C2 only)

This unit can also be connected to a PC through an interface module SES-CAMM. SES-CAMM is a computer aided measurement module for connecting multiple subunits of experiments such as Two Probe Setup to same interface on a computer. This feature is particularly useful in making this model compatible with computerized versions of complete experiments from our company.



# DPM-111

## Digital Picoammeter



- Measures current down to 1pA
- All solid state and IC design
- Very low offset current
- Built-in computer interface

### Introduction

This is a very versatile multipurpose equipment for the measurement of low dc currents. It has 6 decade ranges with 100% over-ranging from 10<sup>-9</sup>A to 10<sup>-4</sup>A. For the ease, readings are directly obtained on a 3½ digit DPM. The instrument uses a well designed precision FET input electrometer operational amplifier AD549, which offers the lowest input bias currents (50fA with ±5V supplies) available in any standard operational amplifier. The excellent characteristics of AD549, ultra low bias current, low offset voltage, low drift and low noise have been fully utilized to obtain best results in the present picoammeter. The first operational amplifier AD549 is used in low level current to voltage configuration and the output has been directly read on a 3½ digit panel meter. The instrument is capable of accepting either polarity of the input current. Well-regulated power supplies are incorporated to use the instrument upto 10% changes in a.c. main's voltage.

### Applications

- Current from photo multiplier tubes, photometers etc.
- Leakage currents in solid state devices.
- FET gate and tube grid-currents.
- Current through very high resistance's in conjunction with a power supply. Potentials across semiconductors, piezoelectric system & pH/plon sensitive electrodes.
- Electrical conductivity of air.
- Very low current oxygen sensors.

### Specifications

Multiplier	: X1, X10, X10 <sup>2</sup> , X10 <sup>3</sup> , X10 <sup>4</sup> , X10 <sup>5</sup>
Accuracy	: 0.2% for all ranges
Resolution	: 1pA, 10pA, 100pA, 1nA, 10nA, 100nA
Input Resistance	: 2.5KΩ, 0.25KΩ, 25Ω, 2.5Ω, 0.25Ω, 0.025Ω
Display	: 3½ digit 7 segment LED
Power Supply	: 220V ±10%, 50Hz
Input	: Through BNC connector
Interfacing	: USB (DPM-111-C2 model)
Software	: DACC and CAMM, both Window compatible (DPM-111-C2 model)

# DPM-111-C2

## Digital Picoammeter



- Measures current down to 1pA
- All solid state and IC design
- Very low offset current
- Built-in computer interface

### Introduction

This is a very versatile multipurpose equipment for the measurement of low dc currents. It has 6 decade ranges with 100% over-ranging from 10-9A to 10-4A. For the ease, readings are directly obtained on a 3½ digit DPM. The instrument uses a well designed precision FET input electrometer operational amplifier AD549, which offers the lowest input bias currents (50fA with ±5V supplies) available in any standard operational amplifier. The excellent characteristics of AD549, ultra low bias current, low offset voltage, low drift and low noise have been fully utilized to obtain best results in the present picoammeter. The first operational amplifier AD549 is used in low level current to voltage configuration and the output has been directly read on a 3½ digit panel meter. The instrument is capable of accepting either polarity of the input current. Well-regulated power supplies are incorporated to use the instrument upto 10% changes in a.c. main's voltage.

### Applications

- Current from photo multiplier tubes, photometers etc.
- Leakage currents in solid state devices.
- FET gate and tube grid-currents.
- Current through very high resistance's in conjunction with a power supply. Potentials across semiconductors, piezoelectric system & pH/plon sensitive electrodes.
- Electrical conductivity of air.
- Very low current oxygen sensors.

### Specifications

Multiplier	: X1, X10, X10 <sup>2</sup> , X10 <sup>3</sup> , X10 <sup>4</sup> , X10 <sup>5</sup>
Accuracy	: 0.2% for all ranges
Resolution	: 1pA, 10pA, 100pA, 1nA, 10nA, 100nA
Input Resistance	: 2.5KΩ, 0.25KΩ, 25Ω, 2.5Ω, 0.25Ω, 0.025Ω
Display	: 3½ digit 7 segment LED
Power Supply	: 220V ±10%, 50Hz
Input	: Through BNC connector
Interfacing	: USB
Software	: DACC and CAMM, both Window compatible

# DPM-111-C2

## Digital Picoammeter

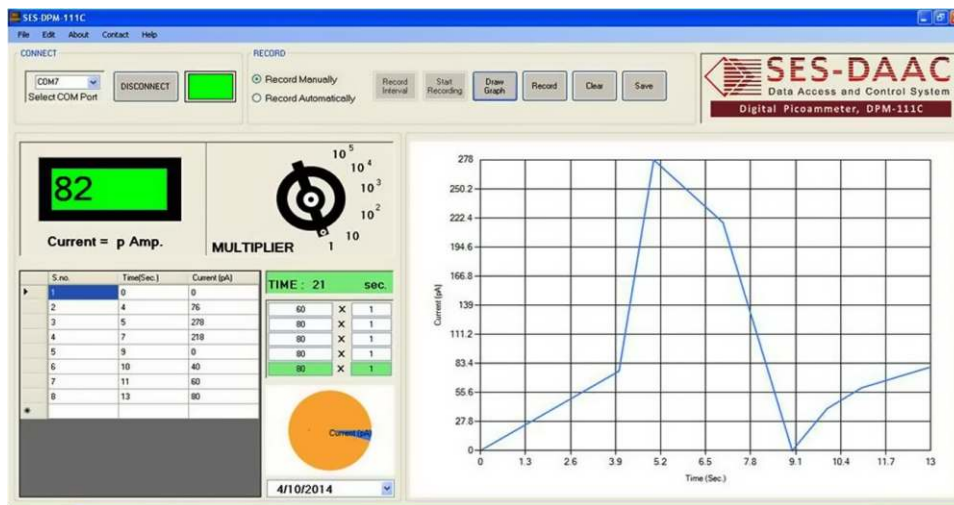

### Computer Interface, SES-DAAC (In DPM-111-C2 only)

The unit can be connected directly to a PC through an USB. SES-Data Access And Control is a built-in interface which gives user an option to store a value as displayed on the meter and tabulate it by the click of a button on the screen. Alternatively the data may be automatically entered into a table at user selectable interval. An 'END' button on the screen terminates the automatic tabulation.

The data stored in the table may then be displayed as graph on the screen and may also be stored in an excel file for further processing. The software supplied with the unit is menu driven and is simple to operate.

### SES-CAMM Compatible (In DPM-111-C2 only)

This unit can also be connected to a PC through an interface module SES-CAMM to record current values. SES-CAMM is a computer aided module for connecting multiple subunits of experiments, such as Two Probe Setup, to same interface on a computer. This feature is particularly useful in making this model compatible with computerized versions of complete experiments from our company.



# EHT-11

## High Voltage Power Supply

- Continuously variable
- Electronically regulated
- Fully solid state circuit
- Low power consumption
- Computer connectivity through SES-CAMM



### Introduction

Power supply, EHT–11 principle of operation is entirely different from conventional supplies, and thereby eliminating many drawbacks; bulky high voltage transformer, need of high voltage components and excessive heating of components etc., associated with them.

This power supply consists of a stable power oscillator whose output is controlled by an input signal. The output of this oscillator is boosted with the help of a step-up transformer and then rectified and filtered. A portion of this output is compared with a high stability, temperature compensated reference and the error signal is used in the feedback path to control the oscillator's output. There is a built-in protection against accidental overloading.

For high reliability, compactness and ruggedness, integrated circuits are extensively used along with a few discrete silicon devices. The components are mounted in a glass epoxy printed circuit card.

### Applications

EHT-11 is designed to meet the power requirements of a broad range of radiation detectors: G.M. Counters, Ionization Chambers, Scintillation Detectors, Photo multiplier Tubes and any application where a high voltage source with high degree of regulation and stability is required.

### SES-CAMM Compatible (In EHT-11-C1 only)

This unit can also be connected to a PC through an interface module SE5-CAMM to record voltage values. SES-CAMM is a computer aided module for connecting multiple subunits of experiments such as Two Probe Setup to same interface on a computer. This feature is particularly useful in making this model compatible with computerized versions of complete experiments from our company.

### Specifications

Output	:	0-1500V continuously adjustable
Current	:	1mA (max.)
Polarity	:	+ve or -ve, as required
Regulation	:	±0.05% for 0 to 1mA load
Stabilization	:	±0.02% for ±10% mains variation
Display	:	3½ digit, 7 segment LED DPM
Connection	:	Output through a TNC connector on the front panel
Protection	:	Fully protected against overload and short circuit by current limiting technique
Interfacing	:	Through SES-CAMM module (In EHT-11-C1 model only)
Software	:	Software provided with SES-CAMM is Window compatible ( In EHT-11-C1 model only)
Power requirements	:	220V ±10%, 50Hz
Weight	:	5Kg
Dimensions	:	240mm X 390mm X 130mm

# ACM-102, ACM-103

## True RMS A.C. Millivoltmeter

- Measures True RMS Voltage
- Accuracy 1%
- High Input Impedance
- High Stability
- Excellent Linearity

### Applications

Measurement of low signal like microphone outputs e.g. in r.m.s. sound level monitoring Amplifier

frequency response well beyond audio ranges RMS voltage measurement of modulated signals Power measurements with external standard resistance.

ACM-102: True RMS A.C. Millivoltmeter, ACM-102 is based on AD536. This is a completely monolithic integrated circuit which performs true rms-to-dc conversion of any waveform. The true rms value of a waveform is more useful quantity than average rectified value, since it relates directly to the power of the signal. The crest factor compensation scheme of the AD536 allows measurement of highly complex signals with wide dynamic range. The crest factor is often overlooked in determining the accuracy of an ac measurement. Crest factor is defined as the ratio of the peak signal amplitude to the rms value of the signal ( $C.F. = V_p / V_{rms}$ ). Input signal is appropriately processed through a FET input wide band, extremely fast settling time, low noise amplifier.



**ACM-103:** In model ACM-103 besides all features of ACM-102, an IC based 1KHz oscillator followed by a buffer, is in-built. This eliminates the need of an external oscillator for purpose, such as determination of h-parameters of a transistor, bridge measurement etc., where spot frequency of 1KHz is most commonly used.

### Specifications

Voltage Range : 20mV, 200mV, 2V and 20V

Frequency Range: 10Hz to 200KHz

Input Impedance: 1MΩ shunted by 25pf on all ranges

Accuracy : 1% in the range 10Hz-100KHz;  
2% in the range 100KHz-200KHz

Display : 3½ digit, 7 segment LED (12.5mm height) with decimal and overflow indication

Power Supply : 220V ±10%, 50Hz

Weight : 2.5Kg & 3Kg

Accessories : 75cm shielded cable with a coaxial connector at one end and banana plugs on the other end

### ACM-103 (Additional Features)

Oscillator Output : 0-300mV continuously variable

Frequency : 1KHz fixed



# Electromagnet & Power Supply

EMU-75  
DPS-175M

SES Instruments Pvt Ltd.

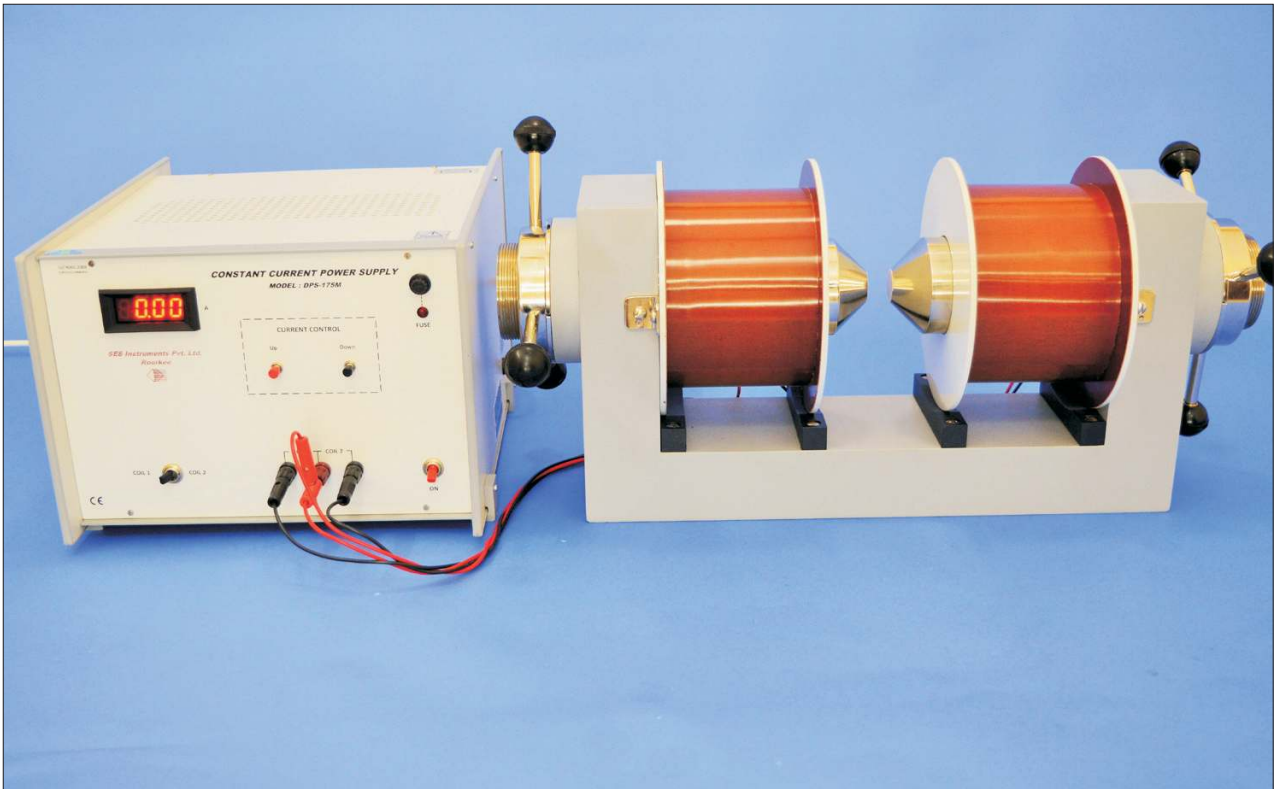

EMU-75 has the most widely used 'U' shaped soft iron yoke. The soft iron is of a special quality, structurally uniform, well machined and finished to meet the rigid standards.

The pole pieces are made from dead annealed soft iron blocks of the best quality available. They are well shaped, machined and finished. The air-gap is continuously variable upto 75mm with two way knobbed wheel screw adjusting system. Normally flat pole pieces are supplied. Tapered pole pieces can be supplied on special request.

The coils are wound on non-magnetic formers with uniform layers of S.E. copper wire. The new and modern design of the coils provides good thermal conductivity characteristics and eliminates troublesome hot spots even at high magnetic fields.

## Specifications

- **Field Intensity**  
11KG at 10mm air-gap with flat pole pieces
- **Pole Pieces**  
75mm diameter
- **Energising Coils**  
Two, each having a resistance of about 12 $\Omega$
-

**DPS-175M** is designed to be used with the Electromagnet, Model: EMU-75 as a constant current power supply to generate magnetic field upto 11KG. The current requirement of 3A per coil, i.e. a total of 6A is met by connecting six closely matched constant current sources in parallel. In this arrangement the first unit works as the 'master' with current adjustment control. All others are 'slave' units generating exactly the same current as the master. All the six constant current sources are individually IC controlled. The current is set by Up/ Down push button switches under the control of a microcontroller. The embedded software further ensures low power dissipation by selecting the primary and secondary tapplings of the mains transformer approximately. The unit is therefore capable of continuously operations for long periods. The supply is protected against overload, short circuit and transients caused by the load inductance.



### Specifications

- **Current Range** : Up/ Down switch operated, 0-3A per coil, i.e. 6A
- **Load Regulation** : 0.1% for load variation from 0 to max.
- **Line Regulation** : 0.1% for  $\pm 10\%$  mains variation
- **Display** : 3½ digit, 7 segment LED DPM
- **Power** : 220V  $\pm 10\%$ , 50Hz
- **Weight** : 13Kg
- **Dimensions** : 340mm X 350mm X 235mm

# Electromagnet & Power Supply

SES Instruments Pvt Ltd.

EMU-75  
DPS-175-C2

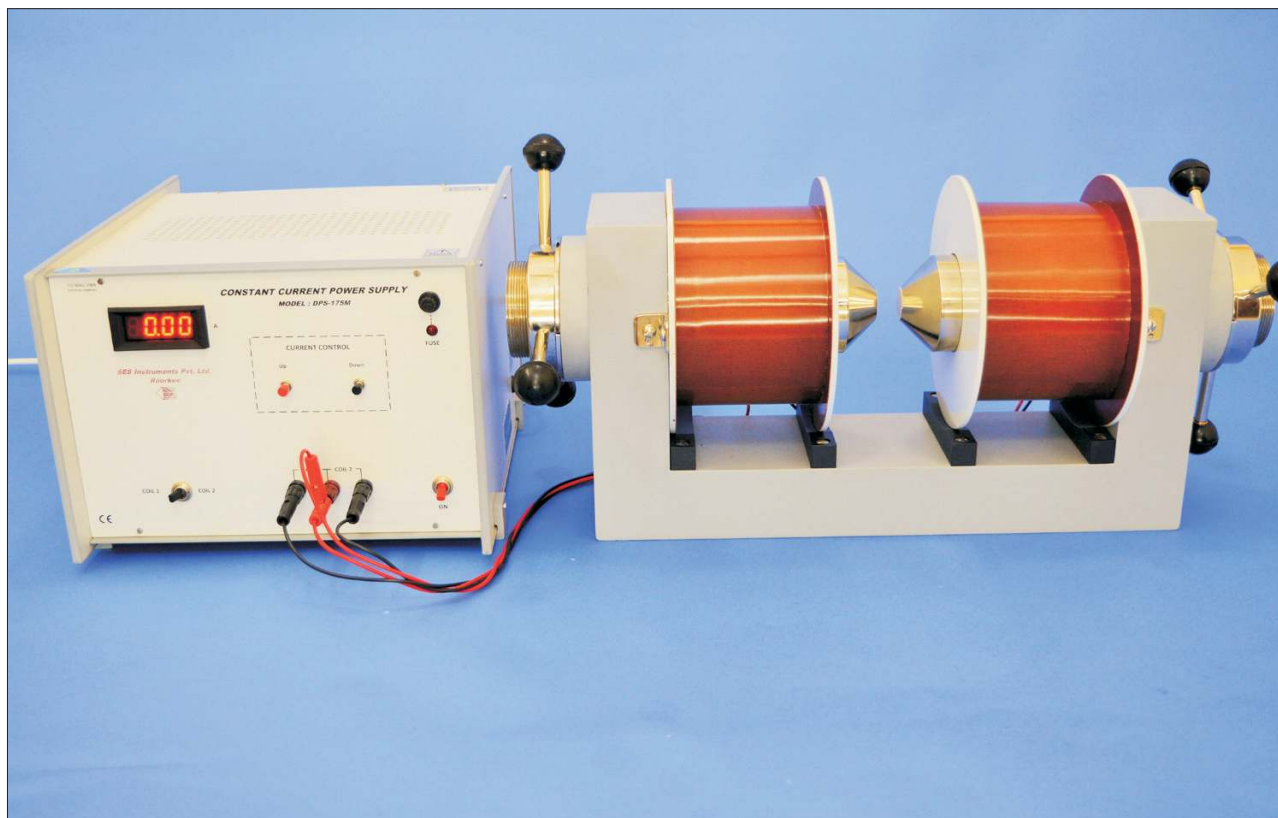

## EMU-75

EMU-75 has the most widely used 'U' shaped soft iron yoke. The soft iron is of a special quality, structurally uniform, well machined and finished to meet the rigid standards.

The pole pieces are made from dead annealed soft iron blocks of the best quality available. They are well shaped, machined and finished. The air-gap is continuously variable up to 75mm with two way knobbed wheel screw adjusting system. Normally flat pole pieces are supplied. Tapered pole pieces can be supplied on special request.

The coils are wound on non-magnetic formers with uniform layers of S.E. copper wire. The new and modern design of the coils provides good thermal conductivity characteristics and eliminates troublesome hot spots even at high magnetic fields.

## SPECIFICATIONS

<b>Field Intensity</b>	11KG at 10mm air-gap with flat pole pieces
<b>Pole Pieces</b>	75mm diameter
<b>Energizing Coils</b>	Two, each having a resistance of about 12 $\Omega$
<b>Power Requirement</b>	0-90Vdc, 3A, if coils are connected in series. 0-45Vdc, 6A, if coils are connected in parallel
<b>Weight:</b>	81Kg

## DPS-175-C2

DPS-175-C2 is designed to be used with the Electromagnet, Model: EMU-75 as a constant current power supply to generate magnetic field upto 11KG. The current requirement of 3A per coil, i.e. a total of 6A is met by connecting six closely matched constant current sources in parallel. In this arrangement the first unit works as the 'master' with current adjustment control. All others are 'slave' units generating exactly the same current as the master. All the six constant current sources are individually IC controlled. Four options are provided for adjusting current.

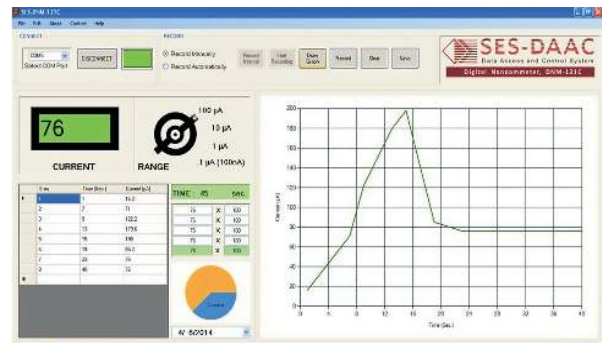

1) **Manual:** Through Up/Down push button switches.

2) **External:** Controlled through a dc voltage 0-10V obtained from dSpace or otherwise.

3) **USB:** The unit can be connected directly to a PC through an USB. SES-Data Access And Control is a built-in interface which gives user an option to store a value as displayed on the meter and tabulate it by a click of a button on the screen. Alternatively the data may be automatically entered into a table at user selectable interval. An 'END' button on the screen terminates the automatic tabulation. The data stored in the table may then be displayed as a graph on the screen and may also be stored in an excel file for further processing. The software supplied with the unit is menu driven and is simple to operate.

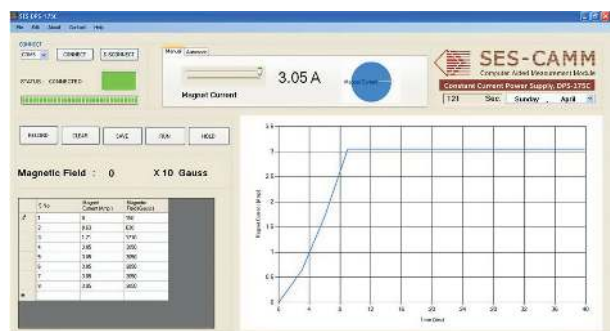

4) **SES-CAMM:** This unit can also be connected to a PC through an interface module SES-CAMM. SES-CAMM is a computer aided module for connecting multiple subunits of experiments, such as Two Probe Setup to same interface on a computer. This feature is particularly useful in making this model compatible with computerized versions of complete experiments from our company.

## SPECIFICATIONS

- Current Range** : Up/ Down switch operated, 0-3A per coil, i.e. 6A
- Load Regulation** : 0.1% for load variation from 0 to max.
- Line Regulation** : 0.1% for  $\pm 10\%$  mains variation
- Display** : 3½ digit, 7 segment LED DPM
- Interfacing** : USB
- Software** : DACC and CAMM, both Window compatible
- Power** : 220V  $\pm 10\%$ , 50Hz
- Weight** : 13Kg
- Dimensions** : 340mm X 350mm X 235mm

*Computer is not included with the instruments.*

# DPS-175-BPC

## Electromagnet & Power Supply

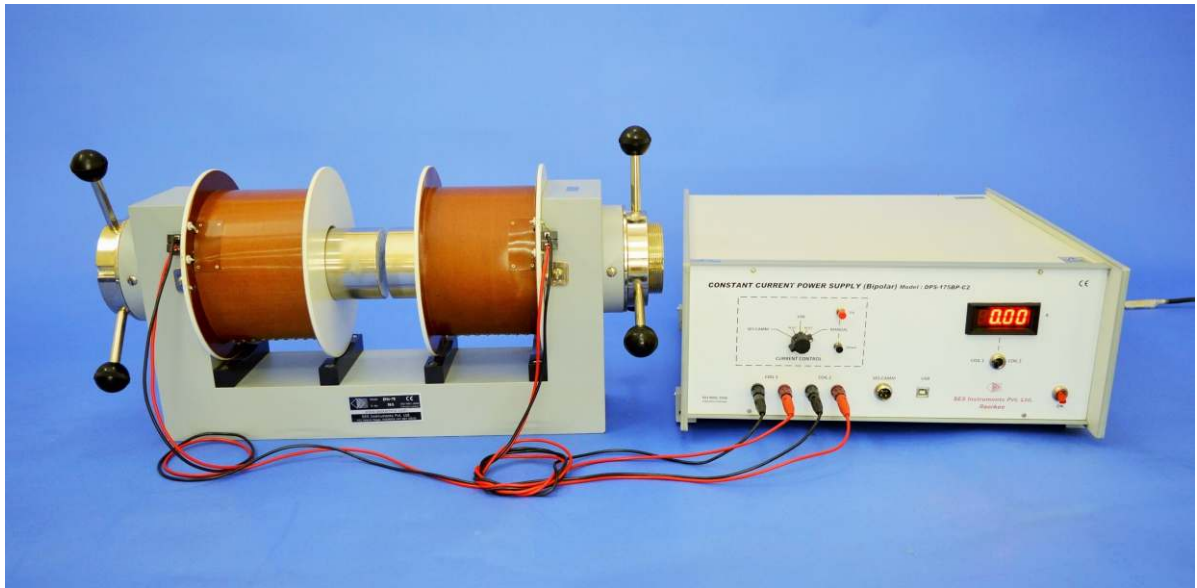

### DPS-175-BPC

DPS-175-BPC is designed to be used with the Electromagnet, Model: EMU-75 as a bi-polar constant current power supply to generate magnetic field up to 11KG. The current requirement of  $\pm 3A$  per coil, i.e. a total of 6A is met by connecting six closely matched constant current sources in parallel. In this arrangement the first unit works as the 'master' with current adjustment control. All others are 'slave' units generating exactly the same current as the master. All the six constant current sources are individually IC controlled. The supply is protected against overload, short circuit and transients caused by inductance of the magnet coil. Three options are provided for adjusting current.

**1) Manual:** Up/ Down push button switches.

**2) USB:** The unit can be connected directly to a PC through an USB. SES-Data Access And Control is a built-in interface which gives user an option to set the current, store and tabulate it by a click of a button on the screen. Alternatively the data may be automatically entered into a table at user selectable interval. An 'END' button on the screen terminates the automatic tabulation. The data Stored in the table may then be displayed as a graph on the screen and may also be stored in an excel file for further processing. The software supplied with the unit is menu driven and is simple to operate.

# DPS-175-BPC

## Electromagnet & Power Supply

**3) SES-CAMM:** The unit can also be connected to a PC through an interface module SES-CAMM. SES-CAMM is a computer aided module for connecting multiple subunits of experiments. This enables the user to set a current profile on the screen and read the current, magnetic field with the help of one of our Gaussmeters and also one more arbitrary parameter. Typical application may be to automatically display the hysteresis loop of a material. This feature is particularly useful in making this model compatible with computerized versions of complete experiments from our company.

### Specifications

Current Range : -3A to +3A each coil connected in parallel

Load Regulation : 0.1% for load variation from 0 to max.

Line Regulation : 0.1% for  $\pm 10\%$  mains variation

Display : 3½ digit, 7 segment LED DPM

Interfacing : USB

Software : DACC and CAMM, both window compatible

Power : 220V  $\pm 10\%$ , 50Hz

Weight : 13Kg

Dimensions : 340mmx350mmx235mm

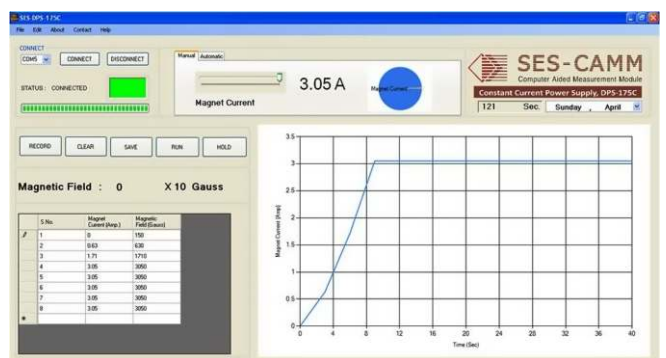
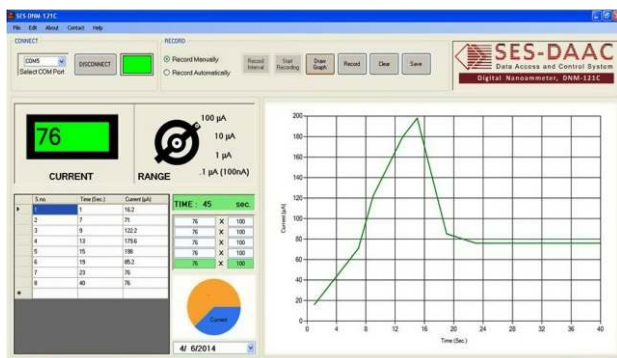

Computer is not included with the instruments.

# EMU-50

## Electromagnet

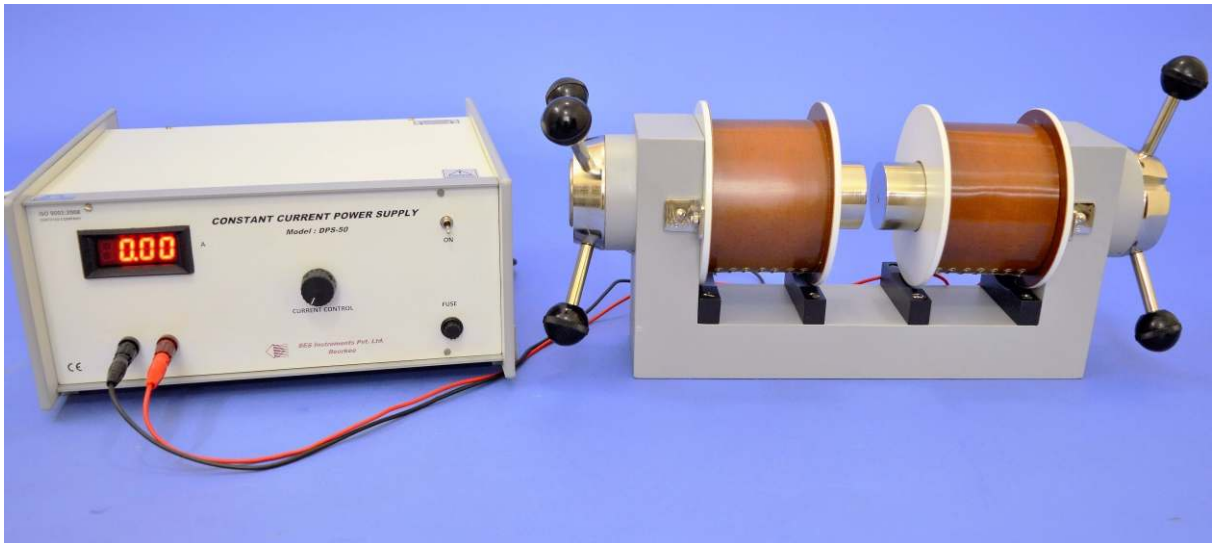

### EMU-50, EMU-50T

These electromagnets have the most widely used 'U' shaped soft iron yoke. The soft iron is of a special quality, structurally uniform, well machined and finished to meet the rigid standards.

The pole pieces are made from dead annealed soft iron blocks of the best quality available. They are well shaped, machined and finished. The air-gap is continuously variable with two way knobbed wheel screw adjusting system. EMU-50V is supplied with flat pole pieces and EMU-50T is supplied with tapered pole pieces.

The coils are wound on non-magnetic former with uniform layers of S.E. copper wire. The new and modern design of the coils provides good thermal conductivity characteristics and eliminates troublesome hot spots even at high magnetic fields.

### Specifications

Field Intensity	:	7.5KG at 10mm air-gap with flat pole pieces (In EMU-50V) 9.0KG at 10mm air-gap with tapered pole pieces (In EMU-50T)
Pole Pieces	:	50mm diameter
Energising Coils	:	Two, each with a resistance of about 3.0Ω
Power Requirement	:	0-30Vdc, 4A, if coils are connected in series
Weight	:	33Kg

Constant Current Power Supply, DPS-50 shown in above picture need to be purchased separately and it is not included in the cost of Electromagnet.

# DPS-50

## Constant Current Power Supply



### DPS-50, DPS-50-C1

DPS-50 is an inexpensive and high performance constant current source suitable for small and medium sized electromagnets. Although the equipment is designed for the Electromagnet, Model: EMU-50, it can be used satisfactorily with any other electromagnet provided the coil resistance does not exceed 6W.

The current regulation circuit is IC controlled and hence results in the highest quality of performance. Matched power transistors are used to share the load current. The supply is protected against overload, short circuit and transient caused by the inductive load of the magnet.

### Specifications

Current Range	: Smoothly adjustable from 0-4A
Load Regulation	: 0.1% for load variation from 0 to max.
Line Regulation	: 0.1% for $\pm 110\%$ mains variation
Display	: 3½ digit, 7 segment LED DPM
Power	: 220V $\pm 10\%$ , 50Hz
Weight	: 9Kg
Dimensions	: 335mm X 305mm X 155mm

### SES-CAMM Compatible (In DPS-50-C1 only)

This unit can also be connected to a PC through an interface module SES-CAMM. SES-CAMM is a computer aided module for connecting multiple subunits of experiment such as Hall Effect Setup to same interface on a computer. This feature is particularly useful in making this model compatible with computerized versions of complete experiments from our company.



# DGM-202

## Digital Gaussmeter (with interchangeable probe)

- Wide range (1G to 20KG)
- Excellent linearity
- Excellent stability
- Interchangeable Hall probes

### Introduction

DGM-202 operates on the principle of Hall Effect in Semiconductors. A semiconductor carrying current develops an electromotive force, when placed in a magnetic field, in a direction perpendicular to the direction of both electric current and magnetic field. The magnitude of this e.m.f. is proportional to the field intensity if the current is kept constant. This e.m.f. is called the Hall Voltage. The small Hall Voltage is amplified through a high stability amplifier so that a millivoltmeter connected at the output of the amplifier can be calibrated directly in magnetic field unit (gauss).

### Applications

- Wide application in industry where accurate measurements of magnetic field is required.
- Measurement of steady magnetic field e.g. in loud speakers, dynamo, moving coil instruments etc.
- Useful in laboratory experiment involving measurement of magnetic field.
- With easy interchangeability of Hall Probe, same gaussmeter can be used with both transverse and axial probe.

### SES-CAMM Compatible (In DGM-202-C1 only)

This unit can also be connected to a PC through an interface module SES-CAMM. SES-CAMM is a computer aided module for connecting multiple subunits of experiments, such as Hall Effect Setup, to same interface on a computer. This feature is particularly



useful in making this model compatible with computerized versions of complete experiments from our company.

### Specifications

Resolution	: 1 gauss at 2 kilogauss range
Range	: 2KG and 20KG
Accuracy	: $\pm 0.5\%$
Temperature	: Upto 40°C
Display	: 3½ digit, 7 segment LED DPM with auto polarity and overflow indication
Power	: 220V $\pm 10\%$ , 50Hz
Transducer	: Hall Probe-GaAs
Special Feature	: Indicates the direction of the magnetic field
Interfacing	: USB (In DGM-202-C1 model only)
Software	: DACC and CAMM, both Window compatible (In DGM-202-C1 model only)
Weight	: 3Kg
Dimensions	: 280mm X 255mm X 120mm

# DGM-204

## Digital Gaussmeter (with wide measurement range)

- Wide range (0.1G to 40KG)
- Excellent linearity
- Excellent stability
- Interchangeable Hall probes
- Built-in computer interface



### Introduction

DGM-204 operates on the principle of Hall Effect in semiconductors. A semiconductor carrying current develops an electromotive force, when placed in a magnetic field in a direction perpendicular to the direction of both electric current and magnetic field. The magnitude of this e.m.f. is proportional to the field intensity if the current is kept constant. This e.m.f. is called the Hall Voltage. This small Hall Voltage is amplified through a high stability amplifier so that a millivoltmeter connected at the output of the amplifier can be calibrated directly in magnetic field unit (gauss).

### Applications

- Current from photo multiplier tubes, photometers etc.
- Wide application in industry where accurate measurements of magnetic field is required.
- Measurement of steady magnetic field e.g. in loud speakers, dynamo, moving coil instruments etc.
- Useful in laboratory experiment involving measurement of magnetic field.
- With easy interchangeability of Hall Probe, same gaussmeter can be used with both transverse and axial probe.

### Specifications

Resolution	: 0.1 gauss at 200G range
Range	: 200G, 2KG, 20KG and 40KG.
Accuracy	: $\pm 0.5\%$ , $\pm 1/2$ digit at 2KG, 20KG & 40KG range $\pm 1\%$ ; $\pm 1$ digit at 200G range
Temperature	: Upto 40°C
Display	: 3 1/2 digit, 7 segment LED with autopolarity and decimal indication
Power	: 220V $\pm 10\%$ , 50Hz
Special Feature	: Indicate the direction of the magnetic field
Interfacing	: USB ( In DGM-204-C2 model)
Software	: DACC and CAMM, both Window compatible (In DGM-204-C2 model)
Weight	: 3Kg
Dimensions	: 280mm X 255mm X 120mm

Computer interface available in DGM-204-C2 Model.

# DGM-204

## Digital Gaussmeter (with wide measurement range)

Page-2

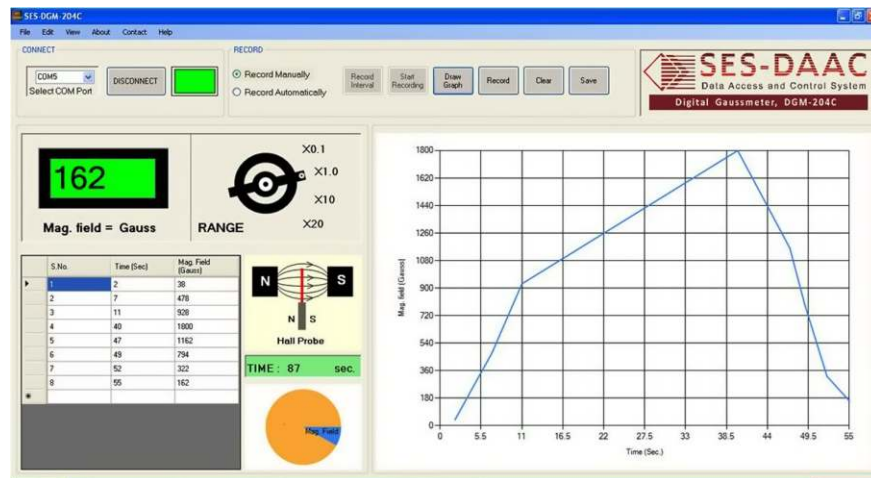

### Computer Interface, SES-DAAC (In DGM-204-C2 only)

The unit can be connected directly to a PC through an USB port. SES-Data Access And Control is a built-in interface which gives user an option to store a value as displayed on the meter and tabulate it by the click of a button on the screen. Alternatively the data may be automatically entered into a table at user selectable interval. An 'END' button on the screen terminates the automatic tabulation.

The data stored in the table may then be displayed as a graph on the screen and may also be stored in an excel file for further processing. The software supplied with the unit is menu driven and is simple to operate.



### SES-CAMM Compatible (In DGM-204-C2 only)

This unit can also be connected to a PC through an interface module SES-CAMM to record magnetic field values. SES-CAMM is a computer aided module for connecting multiple subunits of experiments such as Hall Effect Setup to same interface on a computer. This feature is particularly useful in making this model compatible with computerized versions of complete experiments from our company.



# Digital Gaussmeter

DGM-HH-02

SES Instruments Pvt Ltd.

- Long Battery Life
- Measurement range (1G to 20KG)
- DC to 50 kHz frequency range
- Max. and Min. field capture
- 20 data storage location
- Self calibration of Hall Probe



## Introduction

DGM-HH-02 operates on the principle of Hall Effect in semiconductors. A semiconductor carrying current develops an electromotive force when placed in a magnetic field. The direction of this emf is perpendicular to both the electric current and the magnetic field directions. Also this emf, called hall voltage, is proportional to the intensity of the magnetic field if the current is kept constant. The small Hall Voltage is amplified in the unit by highly stable amplifiers so that its value could be read on an 16x2 LCD. The complete unit operates from a 3200mAh Li-ion battery pack, ensuring 7-8 hrs of continuous operation. Charging cable comes with the unit.

## Specifications

<b>Resolution</b>	1G at 2KG range & 10G at 20KG/ 40KG range
<b>Range</b>	2KG, 20KG
<b>Display Units</b>	Gauss (G), millTesla (mT)
<b>Field</b>	DC/ AC magnetic fields
<b>Measurement Feature</b>	Selectable Range, Max/Min Hold
<b>Memory</b>	Upto 20 data sample storage
<b>Accuracy</b>	$\pm 0.5\%$ $\pm \frac{1}{2}$ digit
<b>Temperature</b>	Upto 60°C (typical) (Sensor temperature can go higher)
<b>Display</b>	16x2 digit, backlit LCD
<b>Power</b>	Li-ion 3200mAh in-built chargeable battery
<b>Transducer</b>	Hall Probe – GaAs (Included)
<b>Special Feature</b>	Indicate the direction of the magnetic field

## Applications

- Wide application in industry where accurate measurements of magnetic field are required.
- Laboratory experiments involving electromagnets.
- Extremely convenient magnetic field measurement in industrial environment. Can operate on battery for long durations without recharging.
- Multiple measurements can be stored and checked later.
- To check maximum and minimum fields of a surface.

# Digital Gaussmeter

DGM-HH-02C

SES Instruments Pvt Ltd.

- Long life rechargeable battery
- Measurement range (1G to 20KG)
- DC to 30kHz frequency range
- Max. and min. field capture
- 25 data storage location
- Self calibration of Hall Probe
- Computer link with software



## Introduction

DGM-HH-02 operates on the principle of Hall Effect in semiconductors. A semiconductor carrying current develops an electromotive force when placed in a magnetic field. The direction of this emf is perpendicular to both the electric current and the magnetic field directions. Also this emf, called hall voltage, is proportional to the intensity of the magnetic field if the current is kept constant. The small Hall Voltage is amplified in the unit by highly stable amplifiers so that its value could be read on an 16x2 LCD. The complete unit operates from a 3200mAh Li-ion battery pack, ensuring 7-8 hrs of continuous operation. Charging cable comes with the unit.

## Specifications

<b>Resolution</b>	1G at 2KG range & 10G at 20KG range
<b>Range</b>	2KG, 20KG
<b>Display Units</b>	Gauss (G), millTesla (mT)
<b>Field</b>	DC/ AC magnetic fields
<b>Measurement</b>	Selectable Range, Max/Min Hold Feature
<b>Memory</b>	Upto 20 data sample storage
<b>Accuracy</b>	$\pm 0.5\%$ $\pm \frac{1}{2}$ digit
<b>Temperature</b>	Upto 60°C (typical) (Sensor temperature can go higher)
<b>Display</b>	16x2 digit, backlit LCD
<b>Power</b>	Li-ion 3200mAh in-built chargeable battery
<b>Transducer</b>	Hall Probe – GaAs (Included)
<b>Connectivity</b>	USB connectivity for data transfer
<b>Special Feature</b>	Indicate the direction of the magnetic field
<b>Calibration</b>	Auto-Calibration

## Applications

- Wide application in industry where accurate measurements of magnetic field are required.
- Laboratory experiments involving electromagnets.
- Extremely convenient magnetic field measurement in industrial environment. Can operate on battery for long durations without recharging.
- Multiple measurements can be stored and checked later.
- To check maximum and minimum fields of a surface.

# Teslameter

TM-400

## Teslameter/ Gaussmeter



- AC/ DC field measurements
- Wide range (0.1G to 40KG)
- Differential mode
- Maximum/ Minimum
- Hold function
- Built-in computer interface



### Introduction

TM-400 operates on the principle of Hall Effect in semiconductors. A semiconductor carrying current develops an electromotive force, when placed in a magnetic field in a direction perpendicular to the direction of both electric current and magnetic field. The magnitude of this e.m.f. is proportional to the field intensity if the current is kept constant. This e.m.f. is called the Hall Voltage. This small Hall Voltage is amplified through a high stability amplifier, the output of which is processed through a microcontroller and displayed on a graphical LCD display.

### Specifications

- Range-1: 0 to  $\pm 4$  Tesla (0 to  $\pm 40$  KiloGauss)
- Range-2: 0 to  $\pm 2$  Tesla (0 to  $\pm 20$  KiloGauss)
- Range-3: 0 to  $\pm 200$  milliTesla (0 to  $\pm 2$  KiloGauss)
- Range-4: 0 to  $\pm 20$  milliTesla (0 to  $\pm 200$  Gauss)
- Display : 4 digit dot matrix graphic LCD, with appropriate decimal placement
- Units: Tesla, Gauss
- Functions: DC, AC (Freq. limited by hall probe)
- Accuracy :  $\pm 0.5\% \pm 1$ digit
- Hall Probe: GaAs, upto 500KHz
- Mode: Normal, Differential
- Hold: Maximum, Minimum
- Refresh Rate: 3 samples per second
- Operating Temperature : Upto 40°C
- Memory Type: Non Volatile, upto 25 samples
- Computer link: USB
- Software : DACC and CMM, both Window compatible
- Power : 220V  $\pm 10\%$ , 50Hz  
110V  $\pm 10\%$ , 50Hz (optional)

# PID-TZ

## PID Controlled Oven

### Introduction

Small ovens are frequently used in class room experiments for the determination of temperature coefficients of resistances, capacitances, zener diodes, and also for studying the leakage currents of semiconductor devices at various temperatures. Conventional arrangement with oven fed from an auto transformer and thermometer type temperature measurement is unsatisfactory due to the long time it takes the oven to heat or cool, large time constant of mercury thermometers and difficulty in setting and maintaining a particular temperature.



### Description

The unit is a high quality PID controller wherein the temperatures can be set and controlled easily. The P, I and D parameters are factory set for immediate use however the user may adjust these for specific applications as well as auto-tune the oven whenever required. The steps for these are given in the user manual. The controller can be used for both small oven, up to 200°C or a larger oven up to 600°C. The controller uses thermocouple as temperature sensor.



Above is 200° oven which is supplied with this unit.  
600°c oven is also available on order.

### Specifications Of The Oven Controller

The controller is designed around Autonics Temperature Controller Model TZN4S. Although this is a very versatile piece of equipment, below is a summary of the specifications that are relevant to the present application.

Temperature Range	: Ambient to 600°C (as per order)
Power Supply	: 00-240VAC; 50/60Hz
Display Method	: 7 Segment LED display [Process value (PV):Red, Set value (SV):Green]
Input Sensor	: Thermocouple (Chromel - Alumel)
Control Method	: PID, PIDF, PIDS
Display Accuracy	: ±0.3%
Setting Type	: Setting by front push bottoms
Proportional Band (P)	: 0 to 100.0%
Integral Time (I)	: 0 to 3600 Sec
Derivative Time (D)	: 0 to 3600 Sec
Control Time (T)	: 1 to 120 Sec
Sampling Time	: 0.5 Sec
Setting (P, I & D)	: Manual / Auto-tuned

# PID-TZ-C1

## PID Controlled Oven (with computer interface)

### Introduction

Small ovens are frequently used in class room experiments for studying the different parameters of various devices/materials at various temperatures. Conventional arrangement with oven fed from an auto transformer and thermometer type temperature measurement is unsatisfactory due to the long time it takes the oven to heat or cool, large time constant of mercury thermometers and difficulty in setting and maintaining a particular temperature.

### Description

The unit is a high quality PID controller wherein the temperatures can be set and controlled easily. The P, I and D parameters are factory set for immediate use however the user may adjust these for specific applications as well as auto-tune the oven whenever required. The steps for these are given in the user manual. The controller can be used for both small oven, up to 200°C or a larger oven up to 600°C. With present setup small oven is provided by default. The controller uses thermocouple as temperature sensor. The setup comes with computer output which can be connected to SES-CAMM unit for further interface to a computer.

### Specifications Of The Oven Controller

The controller is designed around Autonics Temperature Controller Model TK4S. Although this is a very versatile piece of equipment, below is a summary of the specifications that are relevant to the present application.



### Specification

Temperature Range	: Ambient to 600°C (of controller only)
Power Supply	: 100-240VAC; 50/60Hz
Display Method	: 7 Segment LED display [Process value (PV):Red, Set value (SV):Green]
Input Sensor	: Thermocouple (Chromel - Alumel)
Control Method	: PID, PIDF, PIDS
Display Accuracy	: $\pm 0.3\%$
Setting Type	: Setting by front push buttons
Proportional Band (P)	: 0 to 100.0%
Integral Time (I)	: 0 to 3600 Sec
Derivative Time (D)	: 0 to 3600 Sec
Control Time (T)	: 1 to 120 Sec
Sampling Time	: 0.5 Sec
Setting (P, I & D)	: Manual / Auto-tuned
Interface	: Computer Interface through SES-CAMM unit



# TVM-02

## Traveling Microscope

### Introduction

The bed is of a heavy casting, thoroughly aged and machined, is fitted with leveling screws. On the dovetail guide ways slides the horizontal carriage which can be clamped at any position by means of a thumbscrew. A second sliding carriage slides along a gunmetal vertical pillar fitted on the horizontal carriage. The slow motion guide bars are made of sturdy material and the motion is very smooth. For reading convenience, screw gauge arrangement is provided with a large dial.

### Microscope Tube

inclinable in any angle. True vertical and horizontal positions marked focusing.

### Guide Ways

The guide ways over which slides the carriage is made of gunmetal and this makes the instrument Rust Proof, because this is the part which is directly exposed to the weather.

### Scale and Verniers

Made of lifetime Stainless Steel.

### Optics

- (i) True achromatic objective with 7.5 cm. focussing distance from object
- (ii) 10X Ramsden Eyepiece with fine cross wire

### Scale and Verniers

- (i) Horizontal scale : 18cm divided at 1mm interval
- (ii) Vertical scale : 16cm divided at 1mm interval
- (iii) Screw gauge dial : 100 divisions with a least count of 0.01mm

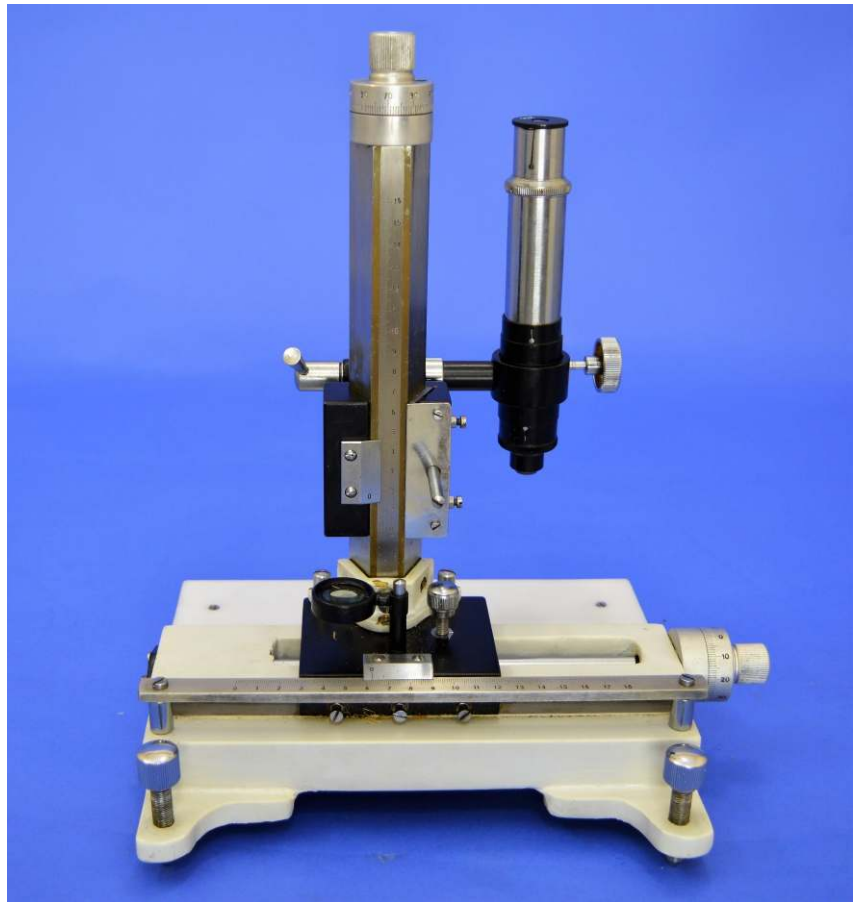

# TVM-03

## Traveling Microscope

### Introduction

The bed is of a heavy casting, thoroughly aged and machined, is fitted with leveling screws. On the dovetailed guide ways slide the carriage which can be clamped at any position by means of a thumbscrew. A sliding carriage slides along a gunmetal Vertical pillar fitted on the horizontal carriage. The slow motion guide bars are made of sturdy material and the motion is very smooth. For reading convenience, screw gauge arrangement is provided with a large dial.

### Microscope Tube

inclined in any angle. True vertical and horizontal positions marked focusing.

### Guide Ways

The guide ways over which slides the carriage is made of gunmetal and this makes the instrument Rust Proof, because this is the part which is directly exposed to the weather.

### Scale and Verniers

Made of lifetime Stainless Steel.

### Optics

True achromatic objective with 7.5 cm. focusing distance from object 10X Ramsden Eyepiece with fine cross wire is provided.

### Scale

20 cm. Horizontally, 15 cm. Vertically and 6 cm Lateral.

### Scale and Verniers

- (i) horizontal scale : 20cm divided at 1mm interval (Screw gauge dial 100 divisions with a least count of 0.01 mm)
- (ii) Vertical scale : 15cm divided at 1mm interval
- (iii) Lateral scale : 6cm divided at 1mm interval

### Scale and Verniers

Horizontal scale : 0.001 cm.

Lateral Scale : 0.001 cm.

Vertical scale : 0.001 cm.

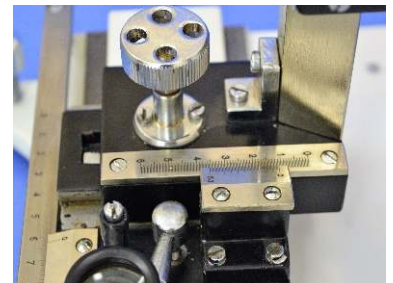
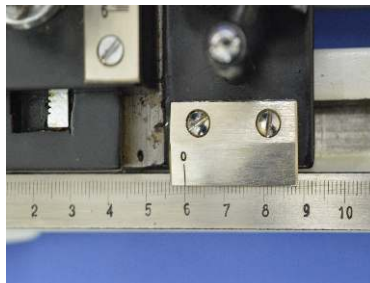
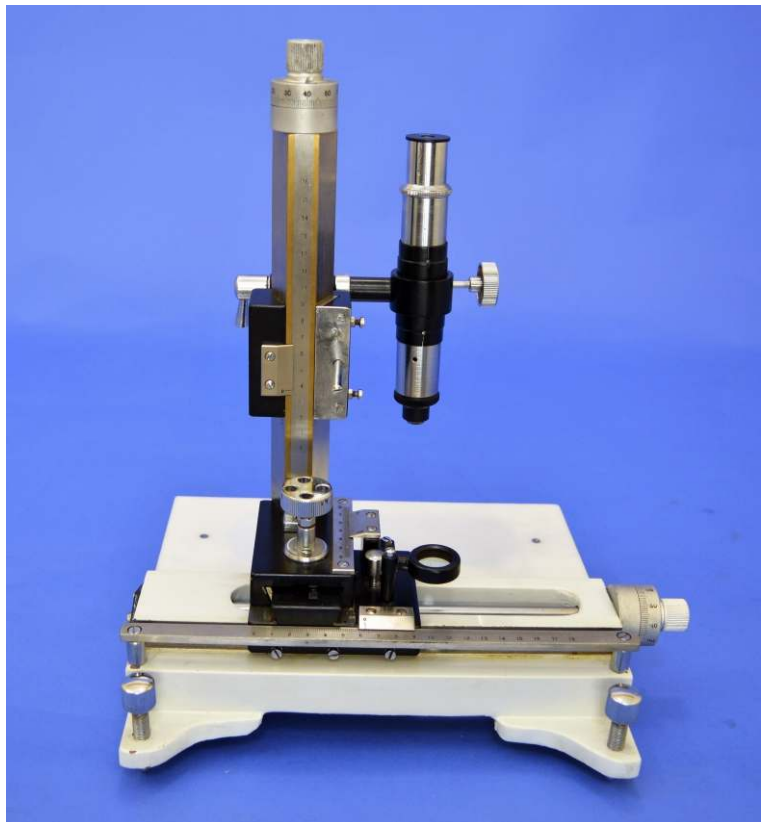

# PS-12

## IC Regulated Power Supply



### Introduction

PS-12 is general purpose power supply consists of four independent fixed voltage regulated sources viz. +12 V, -12 V, +5 V and -5 V referred to a common ground. The current rating for each is specified at 300 mA, although it is possible to exceed this limit safely when all four sources are not operating simultaneously. The compact power supply unit is well suited for any general laboratory which uses linear and digital circuits and IC's. At the same time the excellent performance of the 3-terminal regulators enables the supplies to be used equally satisfactorily for sophisticated instrumentation applications. The built-in protection of the regulator in the form of over current and safe area shutdown ensure continued fault free operation of the unit without any maintenance.

### Specifications

Output voltage	: +12 V, -12 V, +5 V, -5 V fixed
Current	: 300 mA (each supply)
Line Regulation	: $\pm 0.05\%$ for 10 % variation of mains voltage.
Load Regulation	: $\pm 0.1\%$ for a full load of 300 mA
Protection	: Thermal and overcurrent.
Dimensions	: 210 m.m. X 180 m.m. X 100 m.m.
Weight	: 2.25 Kg

# DDS Function Generator

JDS6600

## 60MHz Digital Control Dual-channel DDS Function Signal Generator/frequency meter

- 2.4" Color TFT display
- Precise stable, low distortion output
- Dual channel output
- Storage Feature
- Counter function
- USB Interface
- Arbitrary waveform editing function



### Introduction

JDS6600 is a dual-channel high precision multifunctional signal generator. It adopts large scale of FPGA integrated circuits, high-speed MCU microprocessor and high precision oscillator, which make the signals highly stable. It contains two independent dual-channel DDS signal and TTL level output and is capable of generating sine/triangle/square/sawtooth/pulse wave, white noise, etc. This is a multifunction instrument capable of generating signal, scanning waveform and measuring various electrical parameters. With frequency range of upto 60MHz, it has built-in functions including amplitude modulation and frequency sweep function etc. Output signal amplitude and frequency are continuously displayed. It's a great testing/measuring instrument for electronics engineers, electronic laboratory, teaching and research.

## Specifications

### Frequency Characteristics

Sine frequency range	: 60MHz
Square/Triangle frequency range	: 60MHz
Pulse frequency range	: 6MHz
Square rise time	: 25nS

### Waveform Characteristics

Waveform	: Sine, Square, Triangle, Pulse), Partial Sine, DC level, Half-wave, Full-Wave, Positive Ramp, Negative Ramp, and many other user defined waveforms
Waveform length	: 2048 points
Waveform sampling rate	: 266 MSamples/s
Waveform vertical resolution	: 14 bits

### External Measurement Function

Frequency meter function	: 1Hz-100MHz
Counter function	: 0-4294967295 counts
Input signal voltage range	: 2Vpp-20Vpp
Pulse width measurement	: 0.01us (resolution),
Period measurement	: 20s (max measuring time)

### General technical parameters

Display	: 2.4 inch TFT color LCD
Interface	: USB to serial interface
Communication speed	: 115200bps
Communication protocol	: Command-line mode, Open protocol
Power supply voltage	: 5V±0.5V DC
Manufacturing process	: Surface-mount technology, FPGA design, high reliability, long service life

### Environmental conditions

Temperature	: 0-40C, Humidity:<80%
-------------	------------------------

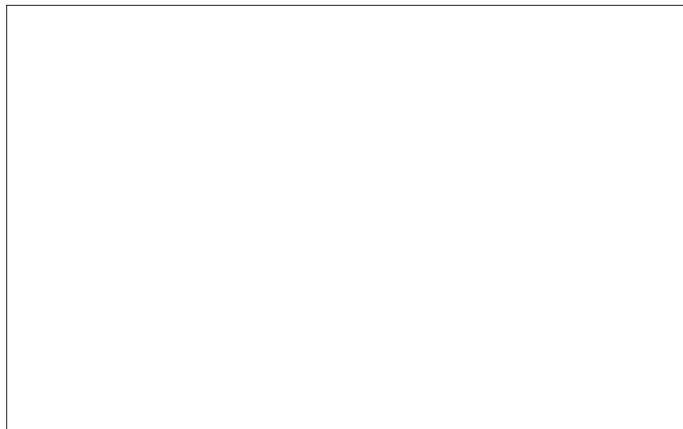

# MFM-01

## Magnetic Field Measurement Apparatus (Biot Savart's Law Set-up)

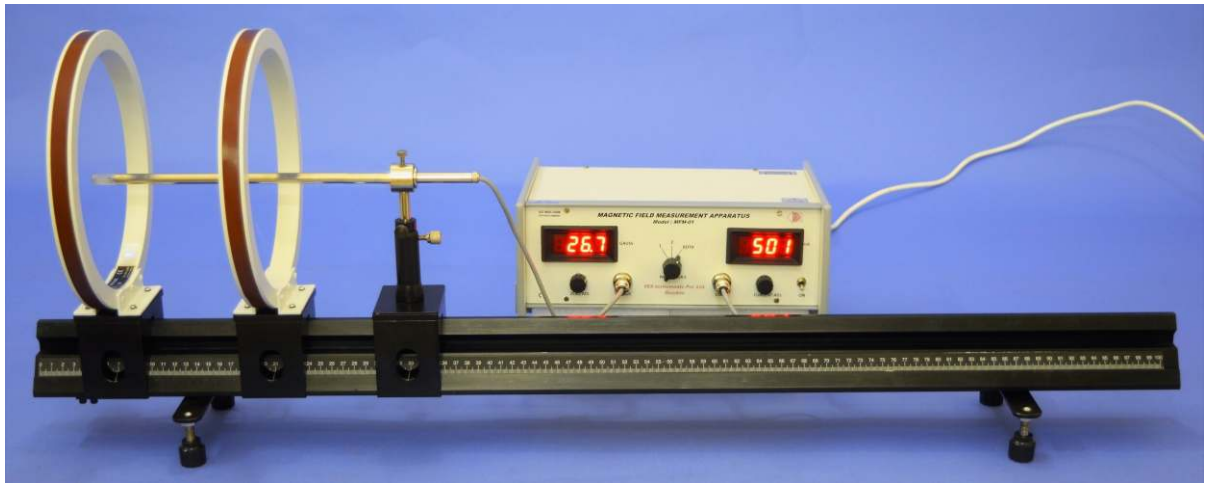

### Introduction

The experiment consists of two coils, Constant Current Power Supply and Gaussmeter. The Gaussmeter probe is mounted on a rail with a scale. It can move smoothly and precisely for measurement of magnetic field along the centre of the coils.

**The following studies Biot Savart's Law can be carried out with the set-up:**

1. Study of magnetic field due to one coil and calculation of its diameter.
2. Study of Principal of super-imposition of magnetic field due to 2 coils by keeping the distance between the coils at  $a$ ,  $>a$  and  $<a$ , where  $a$  is the radius of the coil.

### Legend

- Line 1 : Magnetic Profile when the distance between the coils is  $>a$
- Line 2 : Magnetic Profile when the distance between coils is  $=a$
- Line 3 : Magnetic Profile when the distance between coils is  $<a$   
Superimposition overlaps completely

### Apparatus consists of the following

#### 1. Digital Gaussmeter

Range	:	0-200
Resolution	:	0.1G
Accuracy	:	$\pm 0.5\%$
Display	:	3½ digit 7 segment LED with autopolarity.

#### 2. Two Coil

Diameter	:	200mm
Number of turn	:	1000

#### 3. Constant Current Power Supply

Current	:	0-0.5A Smoothly adjustable
Line Regulator	:	$\pm 0.2\%$ for 10% mains variation.
Load Regulator	:	$\pm 0.2\%$ for 0 to full load
Display	:	3½ digit 7 Segment LED Display
Protection	:	Against overload/ short current.

The 2 coils are mounted on platform one coil is fixed and other coil move smoothly on a rail along with the axis of the coils.

**The experiment is complete in itself.**

# DEC-01

## Study Dielectric Constant

### Study of Dielectric Constant and Curie Temperature of Ferroelectric Ceramics

Dielectric or electrical insulating material are understood as the material in which electrostatic field can persist for long times. Layers of such substance are commonly inserted into capacitors to improve their performance, and the term dielectric refers specifically to this application.

An electric field polarizes the molecules of dielectric producing concentrations of charge on its surface that create an electric field opposed (antiparallel) to that of capacitor. This reduces the electric potential. Considered in reverse, this means that, with a dielectric, a given electric potential causes the capacitor to accumulate a larger charge.

#### Applications

Beside the common and well known application of capacitors in electrical and electronic circuits, the capacitors with an exposed and porous dielectric can be used to measure humidity in air.

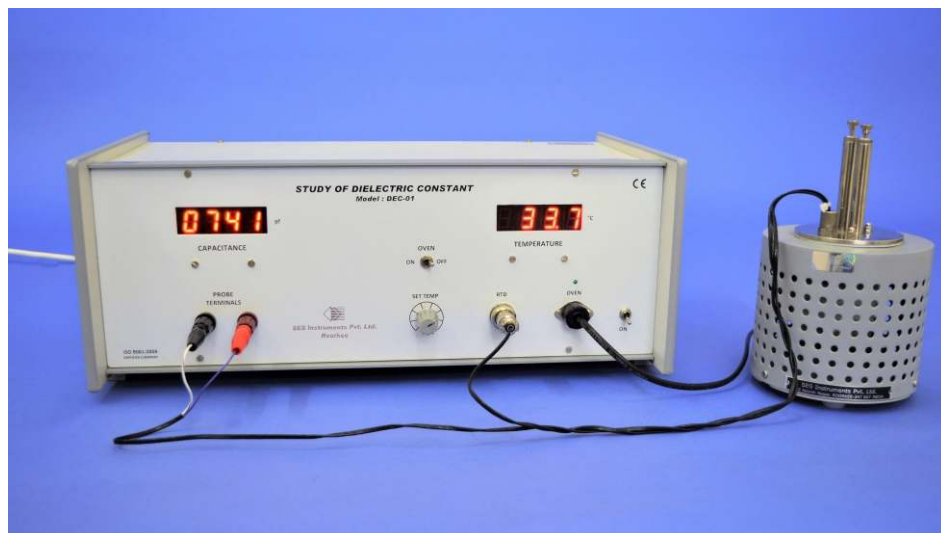

in capacitor applications and piezoelectric transducer devices. Since then, many other ferroelectric ceramics have been developed and utilized for variety of applications: various type of capacitors, non volatile memories in computers, etc.

#### Perovskite Structure

Perovskite is family name of a group of materials and the mineral name of calcium titanate ( $\text{CaTiO}_3$ ) having a structure of the type  $\text{ABO}_3$  (Fig 1)

A practical advantage of perovskite structure is that many different cations can be substituted on both A and B sites without changing the over all structure. Even though two cations are compatible in solution, their behaviour can be radically different when apart from each other. Thus it is possible to manipulate material's properties such as Curie temperature or dielectric constant with only a small substitution of given cation.

All ferroelectric material have a transition called the Curie point ( $T_c$ ). At  $T > T_c$ , the crystal does not exhibit ferroelectricity, while for  $T < T_c$  it is ferroelectric. If there is more than one ferroelectric phase, the temperature at which the crystal transforms one phase to another is called transition temperature. Near the Curie temperature point or transition temperatures, the thermodynamic properties including dielectric, elastic, optical and thermal constants show an anomalous behavior.

Fig.2 shows the variation of dielectric constant ( $\epsilon$ ) with temperature for Lanthanum doped Lead Zirconate Titanate (PLZT) ceramic, which is cooled from its paraelectric cubic

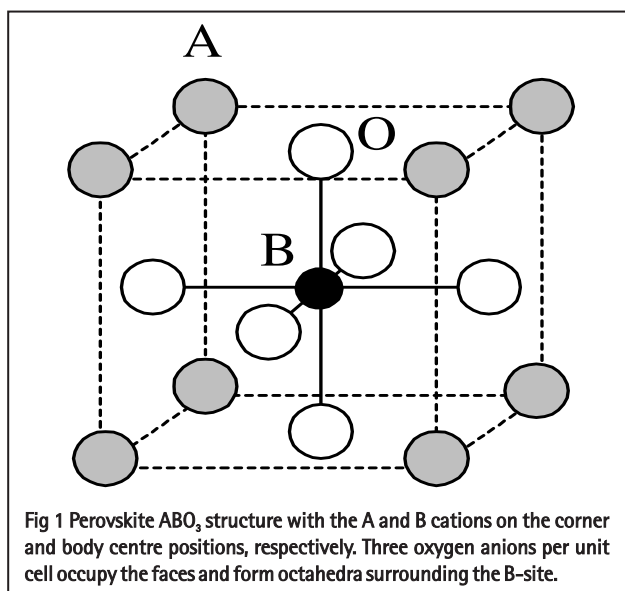

A huge leap in the research on dielectric (ferroelectric materials) came in 1950's, leading to the wide spread use of Barium Titanate ( $\text{BaTiO}_3$ -Perovskite Structure) based ceramics

### Description of the Experimental Set-up

#### 1. Probes Arrangement

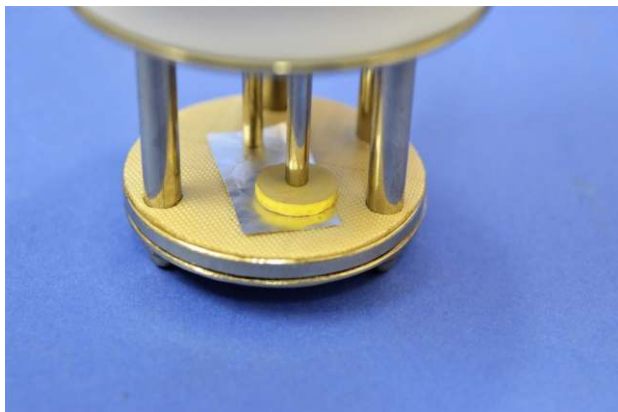

It has two individually spring loaded probes. The probes arrangement is mounted in a suitable stand, which also holds the sample plate. To ensure the correct measurement of sample temperature, the RTD is embedded in the sample plate just below the sample. This stand also serves as the lid of temperature controlled oven. Proper leads are provided for connection to Capacitance Meter and Temperature Controller.

#### 2. Sample

Barium Titanate ( $\text{BaTiO}_3$ )

#### 3. Oven



This is a high quality temperature controlled oven. The oven has been designed for fast heating and cooling

rates, which enhances the effectiveness of the controller.

#### 4. Main Units

The Set-up consists of two units housed in the same cabinet.

##### (i) Oven Controller

Platinum RTD (A class) has been used for sensing the temperature. A Wheatstone bridge and an instrumentation amplifier are used for signal conditioning. Feedback circuit ensures offset and linearity trimming and a fast accurate control of the oven temperature.

##### Specifications

Temperature Range : Ambient to 200°C

Display : 3½ digit, 7 segment LED with autopolarity & decimal indication

Resolution : 0.1°C

Accuracy : ±0.5°C (typical)

Stability : ±0.1°C

Power : 150W

##### (ii) Digital Capacitance Meter

This is a compact direct reading Instrument for the measurement of capacitance of the sample.

##### Specifications

Range : 50–6000 pf

Resolution : 1pf

Display : 3½ digit, 7 segment LED

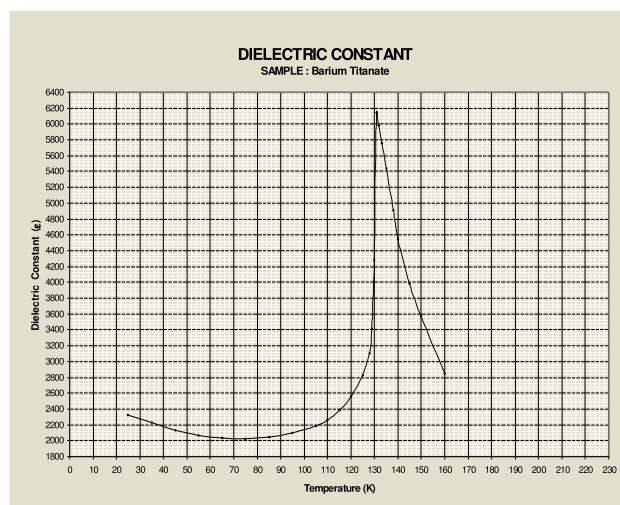

# Frequency Dependence of Dielectric Constant

FDD-01

SES Instruments Pvt Ltd.



## Frequency Dependence of Dielectric Constant

- Capacitance measurement from 1-50kHz
- Dedicated Schering Bridge with built-in oscillator
- Computation of dielectric constant and loss factor
- Samples of Barium Titanate, MLCC and conventional capacitor
- Temperature variation studies with additional equipment oven and controller (optional)
- Essential accessory a CRO, for all the experiments



## Introduction

Barium Titanate,  $\text{BaTiO}_3$ , is a well known and widely investigated dielectric material. It is mainly used in capacitors due to its high dielectric constant. The dielectric properties of  $\text{BaTiO}_3$  are controlled by purity and microstructure which are dependent on the methods of preparation. The ability of the dielectric material to store energy is attributed to the polarization which can result in an increase in capacitance. It is well known that dielectric properties of every solid are very sensitive to the local electric field distribution in the sample. The temperature and frequency dependence of dielectric constant and loss can therefore give useful information about structure changes, transport mechanism and defect behaviour of a solid.

The present experiment is designed to study the variation of capacitance and dielectric

frequency dependent, the performance of a standard multi layer ceramic capacitor (MLCC) and conventional ceramic capacitors are not as prominent. A comparison of these three therefore is an interesting part of the study.

In addition, an optional experiment to study the variation of dielectric constant with temperature at different frequencies is also possible with the help of our PID controlled oven, PID-TZ

### Experiments

- Study of dielectric constant variation with frequency of a Barium Titanate sample
- Study of loss factor with frequency of a Barium Titanate sample
- Study of capacitance variation with frequency of an MLCC capacitor
- Study of capacitance variation with frequency of a conventional ceramic cap.

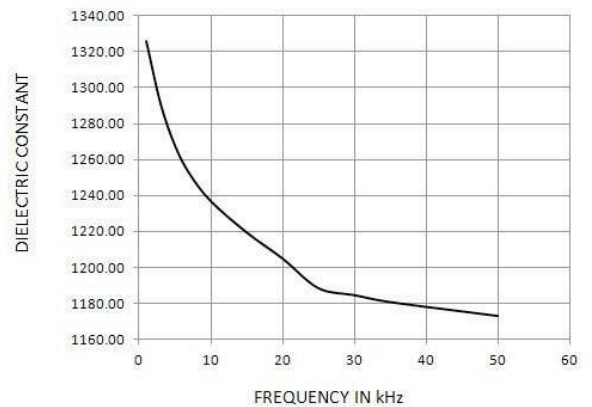

Fig 1  $\epsilon$  vs frequency of Barium Titanate sample

Typical result for Barium Titanate is shown in Fig 1.

### Optional Experiment (Using an additional PID-TZ)

- Study of Dielectric Constant of Barium Titanate as a function of temperature (curie point experiment) and its variation with frequency

Typical results are shown in Fig 2.

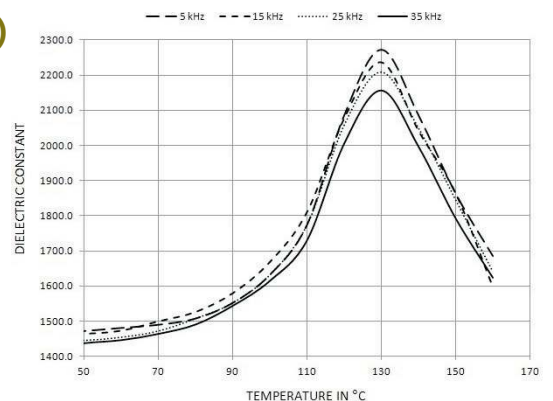
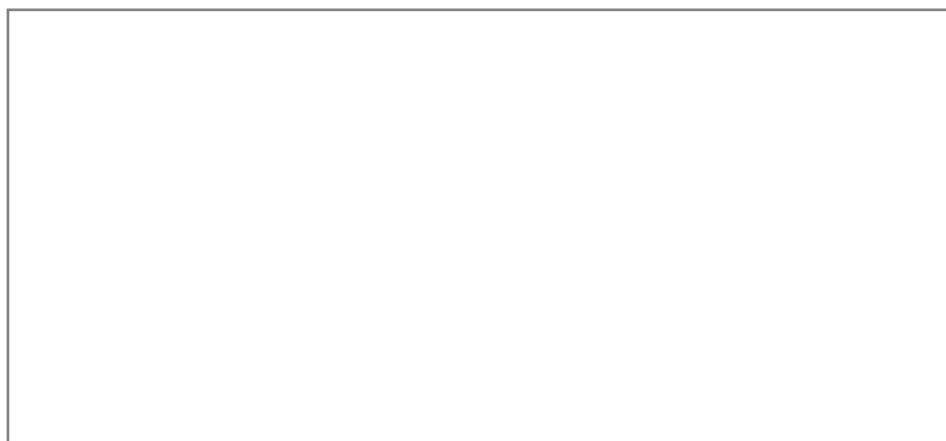

Fig 2  $\epsilon$  vs temperature at various frequencies of Barium Titanate sample



# DCL-01

## Dielectric Measurement Setup

### Dielectric measurement of non-conducting liquids

- High Precision
- Smooth movement
- Accurate measurement
- Easy change of sample

#### Introduction

Dielectric or electrical insulating materials are the substances in which electrostatic field can persist for long times. When a dielectric is placed between the plates of a capacitor and the capacitor is charged, the electric field between the plates polarizes the molecules of the dielectric. This produces concentration of charge on its surface that creates an electric field which is antiparallel to the original field (which has polarized the dielectric). This reduces the electric potential difference between the plates. Considered in reverse, this means that, with a dielectric between the plates of a capacitor, it can hold a larger charge. The extent of this effect depends on the dipole polarizability of molecules of the dielectric, which in turn determines the dielectric constant of the material.

The method for determination of dielectric constants of liquids consists in the successive measurement of capacitance, first in a vacuum, and then when the capacitor is immersed in the liquid under investigation. A cylindrical capacitor has been used here.

### Description of the Experiment Set-up

#### 1. Probes Arrangement

It consists of two polished brass cylinders fixed coaxially with insulating gaskets at the two ends. These gaskets have holes, in the lower one for allowing the experimental liquid to flow in between the cylinders, and in the upper one for communication with the atmosphere. This arrangement is mounted vertically and can be moved up and down with a rack-and-pinion set-up. It is put in a vessel containing the experimental liquid. The outer surface of the outer cylinder has a vertical scale to measure the height of the liquid within the cylinders. Proper leads are provided for connection to the Capacitance Meter.

Sample : Carbon Tetra Chloride

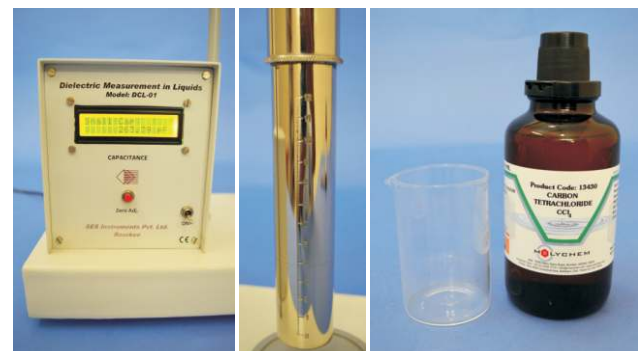

#### 2. Digital Capacitance Meter

This is a compact direct reading micro-controller based high resolution instrument for the measurement of capacitance of the sample.

#### Specification

Range	: 0pf – 50mf
Resolution	: 0.01pf
Display	: 16 x 2 LCD display with back light
Accuracy	: Better than 1%
Zero Setting	: Push button zero setting

# DSL-01

## Dielectric Constant of Solids & Liquids

### Determination of Dielectric measurement of different materials

- High Precision
- Smooth movement
- Accurate measurement
- Easy change of sample

#### Introduction

Dielectric or electrical insulating materials are the substances in which electrostatic field can persist for long times. When a dielectric is placed between the plates of a capacitor and the capacitor is charged, the electric field between the plates polarizes the molecules of the dielectric. This produces concentration of charge on its surface that creates an electric field which is antiparallel to the original field (which has polarized the dielectric). This reduces the electric potential difference between the plates. Considered in reverse, this means that, with a dielectric between the plates of a capacitor, it can hold a larger charge. The extent of this effect depends on the dipole polarizability of molecules of the dielectric, which in turn determines the dielectric constant of the material.

The method for determination of dielectric constant of liquids consist of the successive measurement of capacitance, first outside liquid and then when the capacitor is immersed in the liquid under investigation. A cylindrical capacitor has been used for liquid samples and different size parallel plate capacitors for solid samples.

#### 1. Probes Arrangement

Three probe arrangements are provided with the setup. For solids, two different size arrangements are given, one for 10mm sample pellets and the other for 50mm sample pellets. Both consist of parallel plates set in insulated medium. Sturdy parallel wire lead is used to minimize external disturbance.

For liquids a separate arrangement is provided consisting of two polished brass cylinders fixed coaxially with insulating gaskets at the two ends. These gaskets have holes, in the lower one for allowing the experimental liquid to flow in between the cylinders, and in the upper one for communication with the atmosphere. This arrangement is mounted vertically and can be moved up and down with a rack-and-pinion set-up. It is put in a vessel containing the experimental liquid. The outer surface of the outer cylinder



has a vertical scale to measure the height of the liquid within the cylinders. Proper leads are provided for connection to the Capacitance Meter.

#### 2. Samples

Glass, Bakelite, Teflon, PZT Sample (Lead Titanate), Carbon Tetrachloride Liquid

#### 3. Digital Capacitance Meter

This is a compact direct reading microcontroller based high resolution instrument for the measurement of capacitance of the sample.

#### Specifications

Range	: 0pf – 50mf
Resolution	: 0.01pf
Display	: 16 x 2 LCD display with back light
Accuracy	: Better than 1%
Zero Setting	: Push button zero setting

# DEC-600

## Dielectric Measurement Setup

### Measurement of dielectric constant at high temperature (ambient to 600°C)

#### Introduction

Beside the common and well known application of capacitors in electrical and electronic circuits, the capacitors with an exposed and porous dielectric can be used to measure humidity in air. A huge leap in the research on dielectrics (ferroelectric materials) came in 1950's, leading to the wide spread use of ceramics in capacitor applications and piezoelectric transducer devices. Since then, many other ferroelectric ceramics have been developed and utilized for a variety of applications: various type of capacitors, nonvolatile memories in computers, etc.



#### Description of the Experiment Set-up

##### 1. Probes Arrangement

It has two individually spring loaded probes. The probes arrangement is mounted in a suitable stand of high quality alumina which also holds the sample plate. To ensure the correct measurement of sample temperature, the thermocouple junction is embedded in the sample plate just below the sample. This stand also serves as the lid of temperature controlled oven. Proper leads are provided for connection to Capacitance Meter and Temperature Controller.

##### 2. Sample

Modified lead titanate (test sample)

##### 3. Oven

This is a high quality temperature controlled oven. The heating element used is a high grade Kanthal-D. It is cover. Further the top portion is also suitably covered to meet the safety standard. The oven has been designed for fast heating and cooling rates, which enhances the effectiveness of the controller.

##### 4. Main Units

The Set-up consists of two units housed in the same cabinet.

##### (i) Temperature Controller

It is a high quality PID controller where the temperatures can be set and controlled easily. P, I and D can be adjusted by the user and can also be kept on Auto-tuning.

#### Specification

Temperature Range	Ambient to 600° C
Power Supply	100-240VAC; 50/60Hz
Display Method	7 Segment LED display [Processing value (PV) :Red, Setting value (SV) :Green]
Input Sensor	Thermocouple (Chromel - Alumel)
Control Method	PID, ON/OFF Control, P, PI, PD, PIDF, PIDS
Display Accuracy	± 0.3%
Setting Type	Setting by front push buttons
Proportional Band (P)	0 to 100.0%
Integral Time (I)	0 to 3600 Sec
Derivative Time (D)	0 to 3600 Sec
Sampling Time	0 to 120 Sec
Sampling Time	0.5 Sec
Setting (P, I & D)	Manual / Auto

# DEC-600

## Dielectric Measurement Setup

Page-2

### (ii) Digital Capacitance Meter

It is a handheld instrument, mounted in a cabinet for convenience, It uses CMOS double level A/D convertor that is automatic in zeroing and polar selection.

### Features

- LCD Display
- Data - Hold Switch (HOLD)
- Cx+, Cx - Input Jack
- Back Light Button Switch
- Rotary Switch: Use this switch to select functions and ranges
- Wide measuring range, covering 9 measuring sections from 0.1pf to 20,000 $\mu$ F that includes nominal value of any capacitance
- Power: One 9V battery

### Specification

Range	Accuracy	Definition	Testing frequency
200pF	$\pm 0.5\%$	0.1pF	800Hz
2000pF	$\pm 0.5\%$	1pF	800Hz
20nF	$\pm 0.5\%$	10pF	800Hz
200nF	$\pm 0.5\%$	0.1pF	800Hz
2 $\mu$ F	$\pm 0.5\%$	1nF	800Hz
20 $\mu$ F	$\pm 0.5\%$	10nF	80Hz
200 $\mu$ F	$\pm 0.5\%$	0.1 $\mu$ F	8Hz
2000 $\mu$ F	$\pm 2.5\%$	1 $\mu$ F	8Hz

# ZEX-01

## Zeeman Effect Experiment

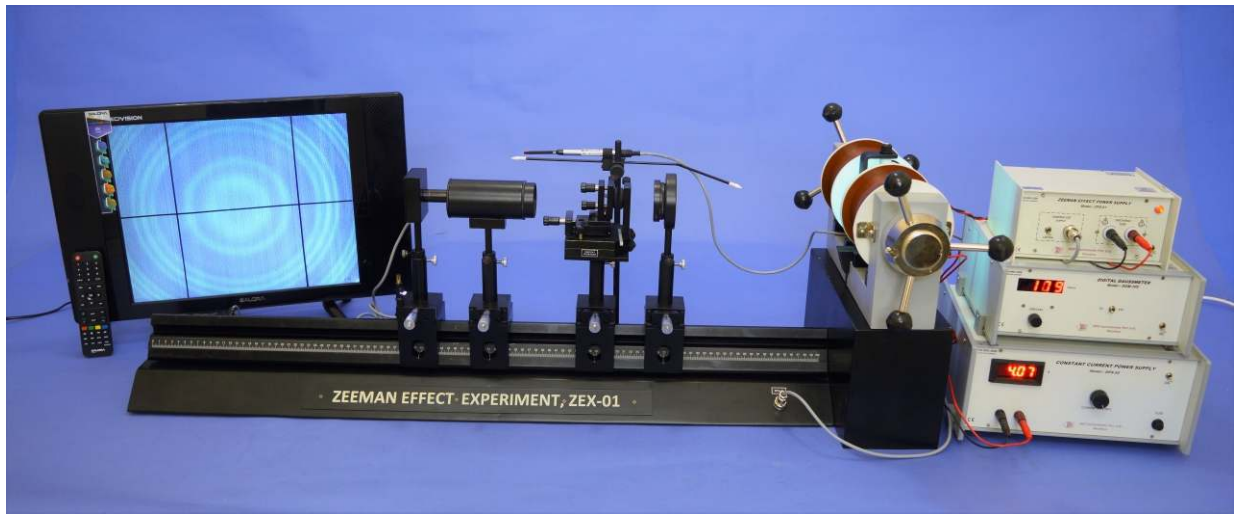

### Introduction

The Zeeman effect is the splitting of spectral lines of atoms when they are placed in a magnetic field. It exhibits space quantization and is one of the few fundamental atomic physics experiments which can be performed in a teaching laboratory.

12. Digital Gaussmeter, DGM-102 (Specifications as per datasheet)

The experimental set-up is complete in all respect.

### Result

The interference pattern is in the form of circular rings. These are split when the magnetic field is switched on. The amount of splitting depends on the external magnetic field, charge to mass ratio of electron and Lande's g-factors of the electronic energy levels

### Description of the Experimental Set-up

Experimental Set-up for Zeeman Experiment

The set-up consists of the following:

1. High Resolution Fabry Perot Etalon, FP-01
2. Mercury Discharge Tube, MT-01 (Low Pressure Mercury Discharge Tube)
3. Power Supply for MT-01, ZPS-02 (High Voltage Power Supply for Discharge Tube)
4. Narrow Band Interference Filter, IF-01
  - Central Wave Length: 546nm
  - Tmax: 74%
  - HBW: 8nm
5. Polarizer with lens, PL-01
6. Optical Bench: OB-01
7. CCD Camera: CAM-700 (High Resolution CCD Camera)
8. Telescope with Focussing Lens: FL-01
9. Monitor 17": TV-17
10. Electromagnet, EMU-50T (Specifications as per datasheet)
11. Constant Current Power Supply, DPS-50 (Specifications as per datasheet)

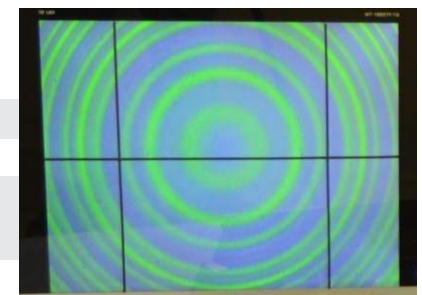
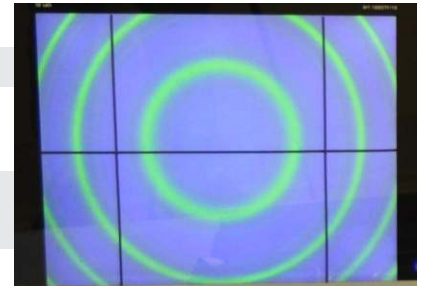

# MOD-01

## Millikans Oil Drop Experiment

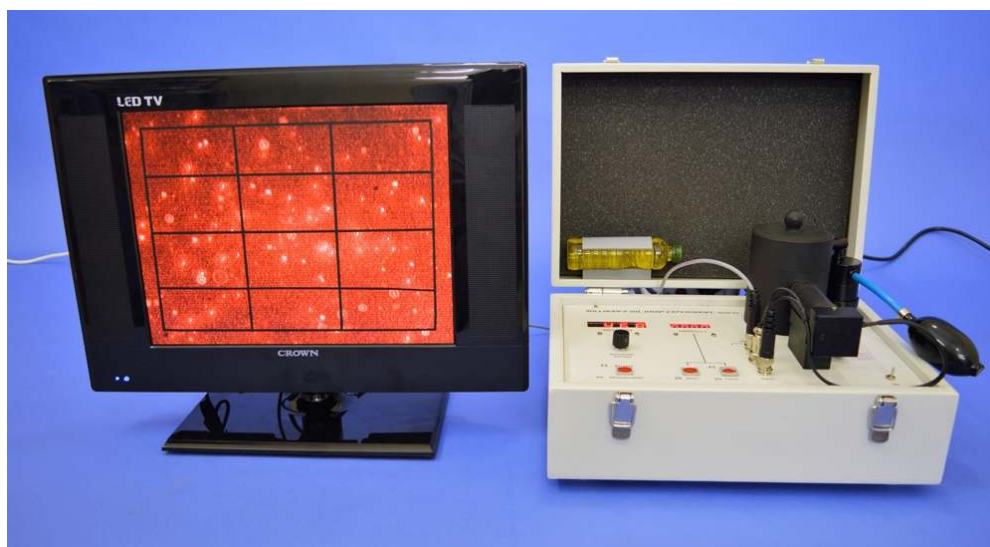

### Introduction

This experiment aims at measuring the charge of an electron and is perhaps the most basic of all atomic physics or modern physics laboratory experiments. It won Millikan the Nobel Prize in the year 1923.

The experiment depends on the ability to control, measure and balance very small force of the order  $10^{-14}$ N. The set-up consists of two horizontal parallel plates separated by about 5mm. The upper plate has a small hole through which microscopic oil droplets are sprayed in between the two plates with the help of an atomizer which is like a common perfume sprayer. These droplets get charged due to the frictional force during spraying. The free fall of these droplets in the space between the plates is observed in the gravitational field. A measurement of the velocity of fall along with the use of Stokes law leads to the calculation of the mass of the droplets and their radii if the oil density is known. These are of the order of  $10^{-15}$ kg and  $10^{-6}$ m respectively. By applying a potential difference between the plates, a uniform electric field is produced in the space between the plates. A measurement of the velocity of the negatively charged droplets rising in the electric field allows a calculation of the electric force on the droplets and hence the charge carried by them. In the experiment the droplets which rise and fall slowly are selected as they are expected to have a fairly small charge. These droplets are made to rise and fall several times. The repetitions of measurement of the velocities of rise and fall reduce the random error of their means. A fairly large number of droplets are observed and their charges are calculated.

The analysis of the data on the total charge carried by the droplets shows that these total charges are integral multiples of a certain smallest charge which is the charge of an electron. This result also shows that the charge is quantized.

The measurement of the charge on the electron can lead to the calculation of Avogadro's number. The charge  $F$  (the Faraday) required to electro-deposit one gram equivalent of an element on an electrode during electrolysis is equal to the charge of the electron multiplied by the number of molecules in a mole. The Faraday has been found to be  $F = 9.625 \times 10^7$  coulombs per kilogram equivalent weight. Hence Avogadro's number  $N = F/e$ .

### Apparatus

The present set-up consists of

1. A oil drop chamber mounted on top of the panel. It has
  - (i) A pair of horizontal parallel plate electrodes separated by about 5 mm thick ebonite ring with a hole for viewing the oil droplets.
  - (ii) The upper plate has a small hole in its centre for the admission of the droplets which are produced by spraying oil with an atomizer.
  - (iii) A device to illuminate the space between the plate electrodes.
2. Three levelling screws at the base of the panel

# MOD-01

## Millikans Oil Drop Experiment

Page-2

to make the parallel plate electrodes perfectly horizontal (perpendicular to the gravitational field) and a water-level placed on top of the panel to check it.

3. A microscope with CCD camera head to view and transmit image of oil droplets between the plate electrodes to the monitor.
4. A power pack to supply continuously variable voltage in the range 0 – 800 V to the upper plate electrode when the electric field is to be created between the plates. The lower plate is permanently grounded.
5. A digital voltmeter to measure the potential applied to the upper plate.
6. A 'Time Meter' to display the time for which the oil droplet is allowed to move.
7. A timing device to measure time interval between the passage of droplets through preset points. There are two keys to operate this device. Pressing the 'Clear' key, wipes out the time information. This is like a reset key. The time meter now reads '00.0' sec. Pressing the 'Start/Stop' key starts the timing device. Pressing it again stops the device. The elapsed time can be read on the meter.
8. A monitor with graduated screen. The horizontal lines on the monitor screen help in setting the distance through which the droplets move.
9. An atomizer to spray droplets.
10. A thermometer to measure the room temperature.

### Method

Time for free-fall of the droplets under gravity between the preset points is measured to obtain the velocity for free-fall. For observing the effect of the electric field on the charge carried by the droplets, there are two alternatives. In the Dynamic method, the velocity for the vertical upward motion is measured for a fixed potential

difference. In the Static method, the potential difference between the plates is adjusted to balance the droplets.

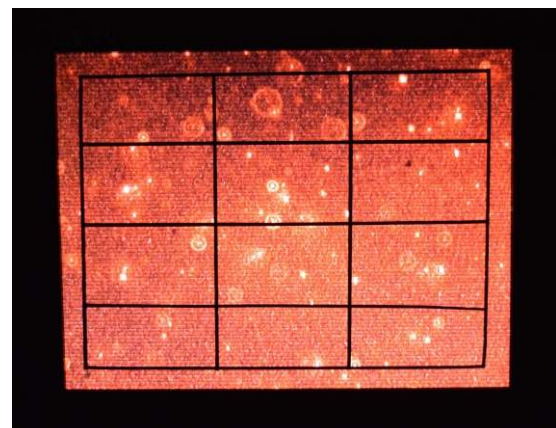
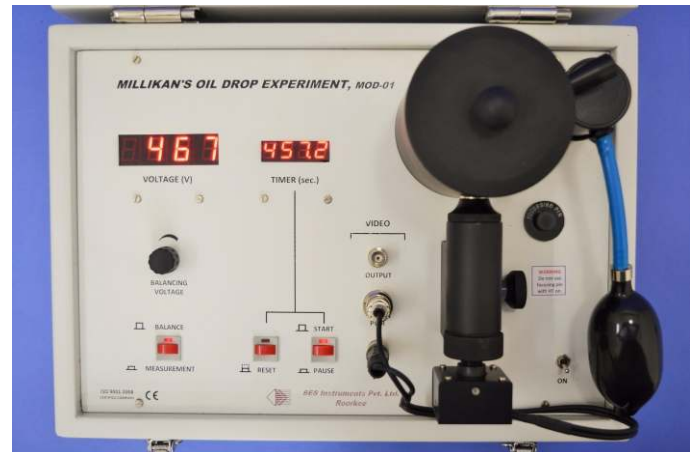

The result of this unit are within 5% of the standard value.

The experiment is complete in all respect.

# PC-101

## Planck's Constant by Photoelectric Effect

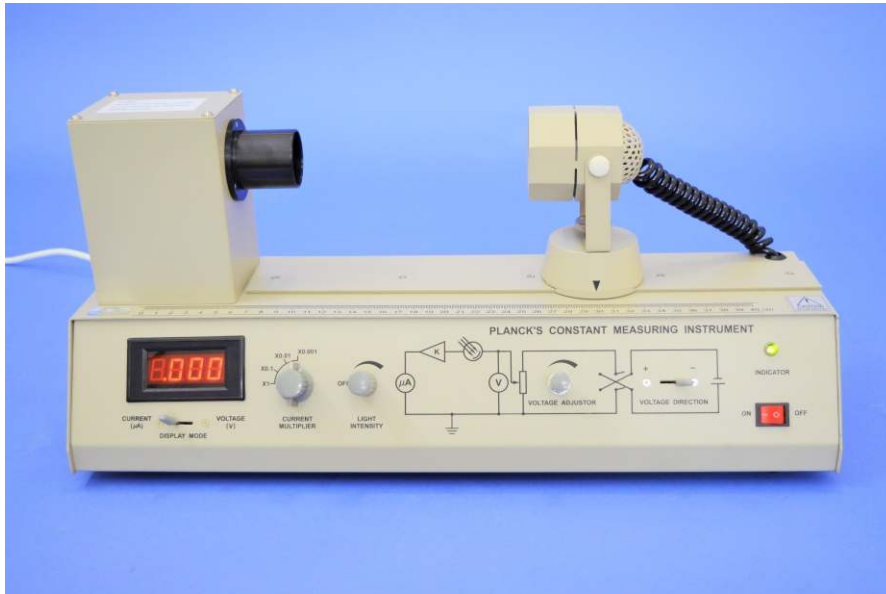

### 1. Determination of planck's constant and work function of materials by photoelectric effect

It was observed as early as 1905 that most metals under influence of radiation, emit electrons. This phenomenon was termed as photoelectric emission. The detailed study of it has shown.

1. That the emission process depends strongly on frequency of radiation.
2. For each metal there exists a critical frequency such that light of lower frequency is unable to liberate electrons, while light of higher frequency always does.
3. The emission of electron occurs within a very short time interval after arrival of the radiation and number of electrons is strictly proportional to the intensity of this radiation.

The experimental facts given above are among the strongest evidence that the electromagnetic field is quantified and the field consists of quanta of energy  $E = h\nu$  where  $\nu$  is the frequency of the radiation and  $h$  is the Planck's constant. These quanta are called photons.

Further it is assumed that electrons are bound inside the metal surface with an energy  $e\phi$ , where  $\phi$  is called work function. It then follows that if the frequency of the light is such that

$$h\nu > e\phi$$

it will be possible to eject photoelectron, while if  $h\nu < e\phi$ , it would be impossible. In the former case, the excess energy of quantum appears as kinetic energy of the electron, so that

$$h\nu = \frac{1}{2}mv^2 + e\phi \quad (1)$$

which is the famous photo electrons equation formulated by Einstein in 1905.

The energy of emitted photoelectrons can be measured by simple retarding potential techniques as is done in this experiment. When a retarding potential  $V_0$  is used to measure kinetic energy of electrons  $E_e$ , we have,

$$E_e = \frac{1}{2}mv^2 = eV_0 \quad \text{or} \quad V_0 = \frac{h}{e}\nu - \phi$$

So when we plot a graph  $V_0$  as a function of  $\nu$ , the slope of the straight line yields  $h$  and the intercept of extrapolated point  $\nu=0$  can give work function  $\phi$ .

# PC-101

## Planck's Constant by Photoelectric Effect

### 2. To verify inverse square law of radiation using a photoelectric cell

If  $L$  is the luminous intensity of an electric lamp and  $E$  is the illuminance (intensity of illumination) at point  $r$  from it, then according to inverse square law.

$$E = \frac{L}{r^2}$$

if this light is allowed to fall on the cathode of a photo-electric cell, then the photo-electric current ( $I$ ) would be proportional to  $E$ .

$$E = \frac{L}{r^2} = K.I$$

Hence a graph between  $\frac{1}{r^2}$  and  $I$  is a straight line, which verify the inverse square law of radiation.

#### The apparatus consist of the following :

1. **Photo sensitive device** : Vacuum photo tube.
2. **Light source** : Halogen tungsten lamp 12V/35W.
3. **Colour filters** : 635nm, 570nm, 540nm, 500nm & 460nm.
4. **Accelerating voltage** : Regulated Voltage Power Supply

Output :  $\pm 15$  V continuously variable through multi-turn pot

Display : 3 1/2 digit 7-segment LED

Accuracy :  $\pm 0.2\%$

5. **Current detecting unit** : Digital Nanoammeter is a high stability low current measuring instrument

Range : 1000 $\mu$ A, 100 $\mu$ A, 10 $\mu$ A & 1 $\mu$ A with 100% over ranging facility

Resolution : 1nA at 1 $\mu$ A range

Display : 3 1/2 digit 7-segment LED

Accuracy :  $\pm 0.2\%$

6. **Power requirement** : 220V  $\pm$  10%, 50Hz.

7. **Optical Bench** : The light source can be moved along it to adjust the distance between light source and photo tube. Scale length is 400 mm. A draw tube is provided to install colour filters, a focus lense is fixed in the back end.

The set is complete in all respect, no additional accessory required.

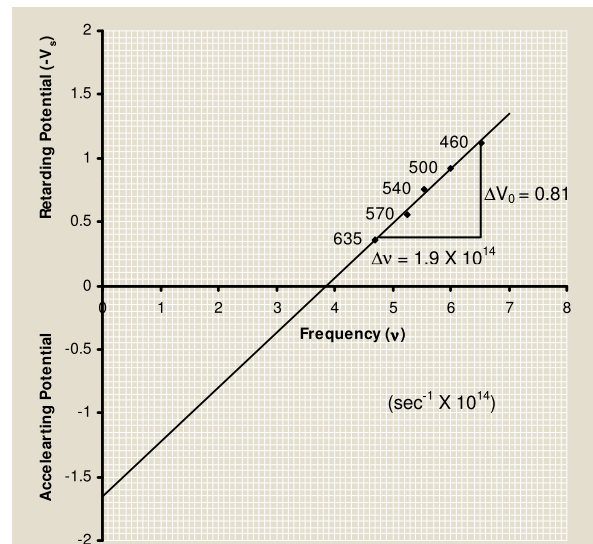

Fig.: Typical graph of  $V_0$  (stopping potential) as a function of  $\nu_0$

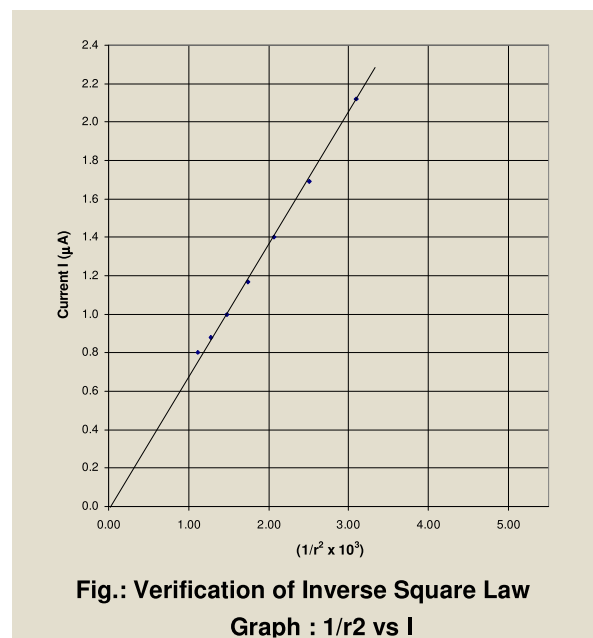

Fig.: Verification of Inverse Square Law  
Graph :  $1/r^2$  vs  $I$

# PCA-01

## Determination of Planck's Constant by means of LED's

- Highly accurate results
- Precise measurement of Band-Gap
- Clear physical interpretation
- Self contained unit with no extra accessory required



### Determination of Planck's Constant using LED

Several proposals to measure the Planck's Constant for didactical purposes, using the current - voltage (I-V) characteristics of a light emitting diode (LED) have been made quite regularly in the last few years. The reason is that the experiment can be done easily in any lab and the results are surprisingly good ( $\pm 10\%$ ). The physical interpretation however is not completely clear and this has raised many discussions, which has been published almost with same regularity as the proposals themselves. The present experiment is based on diode current for  $V < V_0$ , using the diode law.

$$I = I_0 \exp \left[ - \frac{e (V_0 - V)}{\eta k T} \right]$$

where,  $e$  is electronic charge,  $k$  is Boltzmann constant,  $T$  is absolute temperature and  $\eta$  is material constant which depends on the type of diode, the location of recombination region, etc.

The correct method to determine the real height of the potential energy barrier  $V_0$  is to directly measure the dependence of the current on temperature keeping the applied voltage  $V$  slightly below  $V_0$ . The

idea is that the disturbance to  $V_0$  is as little as possible. The slope of  $\ln I$  vs.  $1/T$  curve gives  $e (V_0 - V) \eta k$  (Fig. 1). The constant  $\eta$  is determined from I-V characteristics of the diode (Fig. 2) at room temperature from the relation

$$\eta = (e/kT) (\Delta V / \Delta \ln I)$$

Compared with previous methods, this determination of  $V_0$  is more precise and more accurate and at the same time the physical interpretation is more transparent.

The Planck's constant is then obtained by the relation

$$h = e V_0 \lambda / c$$

The wavelength ( $\lambda$ ) of the light emitted by the diode can be measured by a transmission grating spectrometer normally available in the lab.

The value of Planck's constant obtained from this method is within 5% of accepted value ( $6.62 \times 10^{-34}$  Joules.sec)



### Experimental Set-Up

It is a self contained unit. All the necessary facilities and measuring devices are built in a single unit, as a result only minimum of external connections need to be made.

#### [I] Dependence of current (I) on temperature (T) at constant applied voltage (V)

The following facilities are built in for this

##### (a) Current Meter

A highly stable current meter with 3½ digit display

Range: 0-2mA with resolution of 1µA

##### (b) Oven

It is a small temperature controlled oven with built-in RTD sensor. The temperature is adjustable from ambient to 65°C and displayed on 3½ digit panel meter. The stability of temperature is  $\pm 0.2^{\circ}\text{C}$ .

##### (c) Voltmeter

A high stability voltage source with 3½ digit display

#### [II] Material Constant $\eta$

To draw I-V characteristics of LED for determination of  $\eta$ , a variable voltage source and current meter are provided with 3½ digit display.

#### [III] The wavelength $\lambda$ of light emitted by LED

These are taken from LED datasheet or as measured by transmission grating are provided with the set of LED's

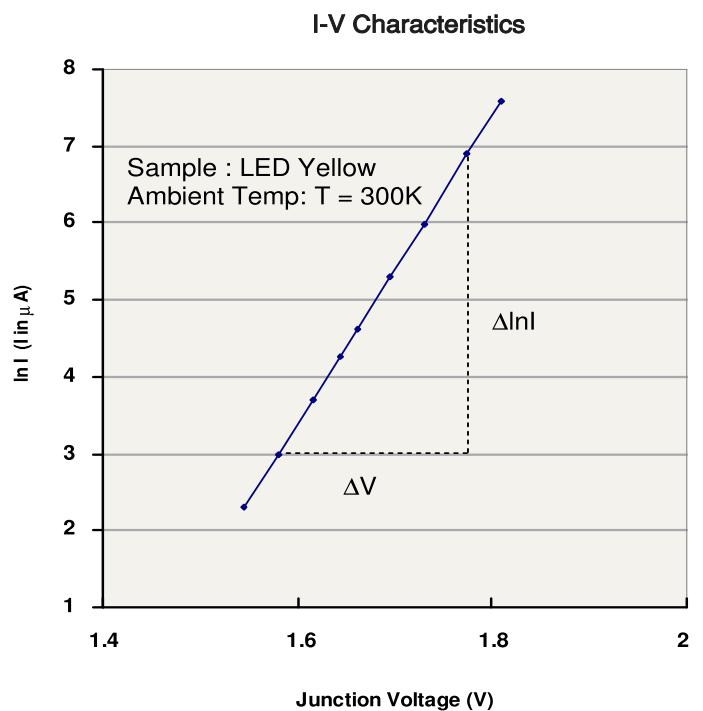
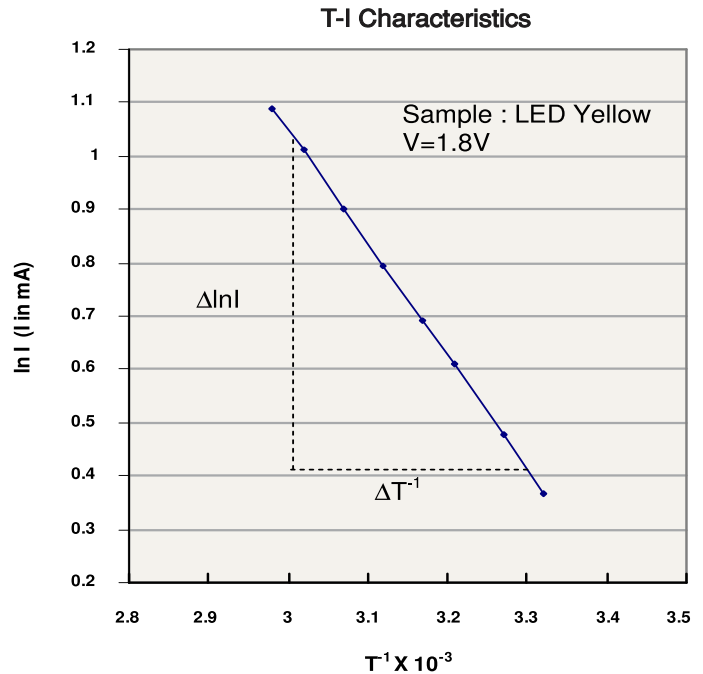

# FH-3001

## Frank Hertz Experiment

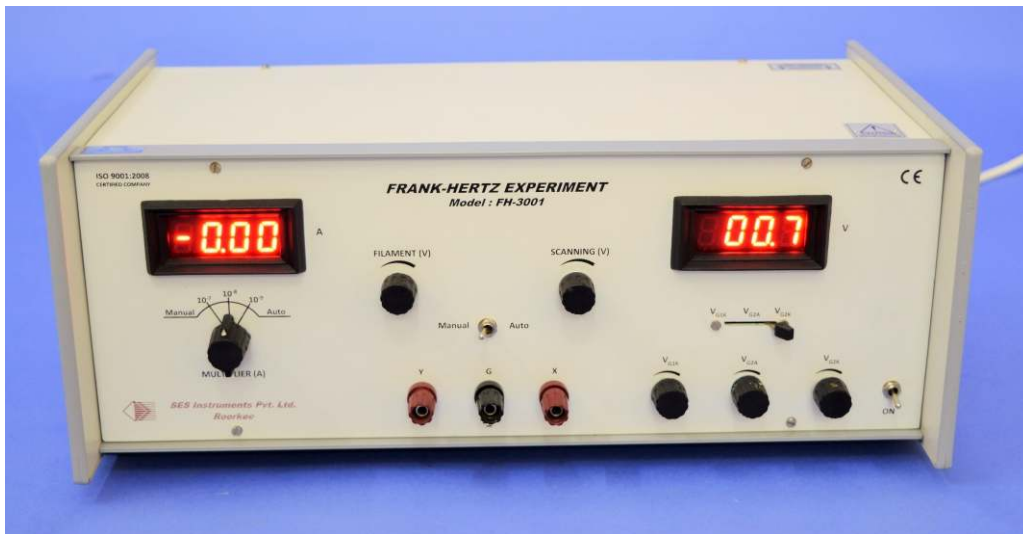

### Introduction

From the early spectroscopic work it is clear that atoms emitted radiation at discrete frequencies; from Bohr's model, the frequency of the radiation  $\nu$  is related to the change of energy levels through  $\Delta E = h\nu$ .

It is then to be expected that transfer of energy to atomic electrons by any mechanism should always be in discrete amounts. One such mechanism of energy transfer is through inelastic scattering of low-energy electrons.

Frank and Hertz in 1914 set out to verify these considerations.

- (i) It is possible to excite atoms by low energy electron bombardment.
- (ii) The energy transferred from electrons to the atoms always had discrete values.
- (iii) The values so obtained for the energy levels were in agreement with spectroscopic results.

Thus the existence of atomic energy levels put forward by Bohr can be proved directly. It is a very important experiment and can be performed in any college or University level laboratory.

### Operating Principle

The Frank-Hertz tube in this instrument is a tetrode filled with the vapour of the experimental substance. Fig.1 indicates the basic scheme of experiment.

The electrons emitted by filament can be accelerated by the potential  $V_{G_2,K}$  between the cathode and the grid  $G_2$ . The grid  $G_1$  helps in minimising space

charge effects. The grids are wire mesh and allow the electrons to pass through. The plate  $A$  is maintained at a potential slightly negative with respect to the grid  $G_2$ . This helps in making the dips in the plate current more prominent. In this experiment, the electron current is measured as a function of the voltage  $V_{G_2,K}$ . As the voltage increases, the electron energy goes up and so the electron can overcome the retarding potential  $V_{G_2,A}$  to reach the plate  $A$ . This gives rise to a current in the ammeter, which initially increases. As the voltage further increases, the electron energy reaches the threshold value to excite the atom in its first allowed excited state.

In doing so, the electrons lose energy and therefore the number of electrons reaching the plate decreases. This decrease is proportional to the number of inelastic collisions that have occurred. When the  $V_{G_2,K}$  is

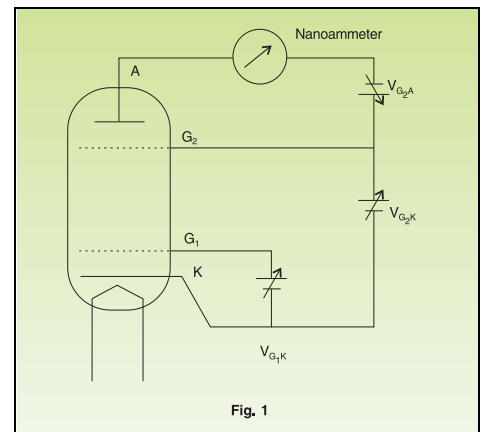

Fig. 1

# FH-3001

## Frank Hertz Experiment

Page-2

increased further and reaches a value twice that of the first excitation potential, it is possible for an electron to excite an atom halfway between the grids, lose all its energy, and then gain anew enough energy to excite a second dip in the current. The advantage of this type of configuration of the potential is that the current dips are much more pronounced, and it is easy to obtain five fold or even larger multiplicity in the excitation of the first level.

Frank-Hertz Experiment Set-up, Model: FH-3001, consists of the following:

Argon filled tetrode

Filament Power Supply : 2.6~3.4V continuously variable

### Grids Power Supplies

- $V_{G_1K}$  : 1.3-5 V continuously variable
- $V_{G_2K}$  : 1.3 - 12V continuously variable
- $V_{G_2K}$  : 0 - 95V continuously variable

All the power supplies are highly stabilised and output voltages can be read on 3 V2 digit, 7 segment LED DPM with autopolarity and decimal indication through a selector switch.

### Saw tooth waveform for CRO display

- Scanning Voltage : 0-80V
- Scanning Frequency :  $115 \pm 20$ Hz

### Multirange Digital Ammeter

- Display :  $3\frac{1}{2}$  digit 7 segment LED
- Range Multiplier: 10-7, 10-8 & 10-9

### Power

- $220V \pm 10\%$  mains, 50Hz

The instrument can, not only lead to a plot of the amplitude spectrum curve by means of point by point measurement, but also directly display the amplitude spectrum curve on the oscilloscope screen. This instrument can thus be used as a classroom experiment as well as for demonstration to a group of students.

### Analysis of the Data

Data obtained for the excitation potential point by point are shown in Fig. 3. The readings are taken for 1V changes on grid 2 ( $V_{G_2K}$ ).

A significant decrease in electron (collector) current is noticed every time the potential on grid 2 is increased by approximately 12V, thereby indicating that energy is transferred from the beam in (bundles) "quanta" of 12eV only. Indeed, a prominent line in the spectrum of argon exists at  $1048\text{\AA}$  corresponding to  $eV=11.83$ .

The location of the peaks is indicated in Fig. 3. Average value of spacing between peaks is 11.75eV compared with the accepted value of 11.83V.

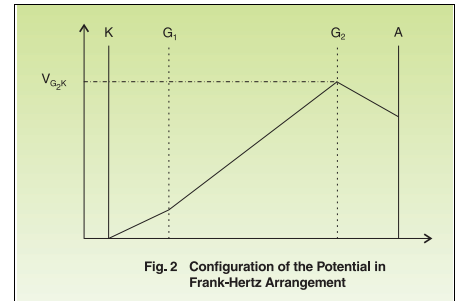

Fig. 2 Configuration of the Potential in Frank-Hertz Arrangement



Fig. 3 Plot of Beam Current Vs. Accelerating Voltage in Frank Hertz Experiment, FH-3001

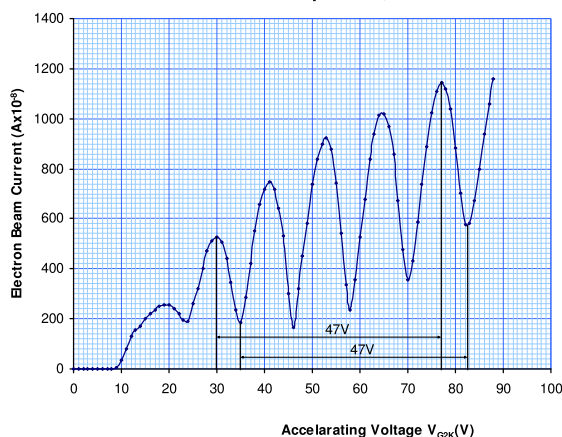

Fig. 4 Oscilloscope display of Frank-Hertz Experiment



# IP-01

## Ionisation Potential



### Introduction

The electrons in the atoms have discrete stationary states. Franck and Hertz in 1914 described the first observation of quantized excitation from one quantized state to another one year after N. Bohr published his theory of hydrogen atom. His method depends on detecting the on-set of inelastic collisions between electrons and atoms of the gas under study. The experimental tube in this measurement is essentially a triode filled with the vapour of the experimental substance. The electrons emitted by the heated filament of the tube are accelerated by the positive potential  $V_{GK}$  between the cathode and the grid. The grid is a wire mesh which allows the electrons to pass through. The anode A is maintained at a fixed potential  $V_{GA}$  slightly negative with respect to the grid. In the experiment the electron current is measured as a function of the voltage  $V_{GK}$ . As  $V_{GK}$  increases, the energy of the electrons increases, and more and more electrons reach the anode. The anode current increases. The collisions between the electrons and the atoms are elastic. As  $V_{GK}$  further increases, the energy of the electrons reaches the threshold for the excitation of the atomic electrons from the ground state to the first excited state, and the collisions between the electrons and the atoms become inelastic. The colliding electrons lose energy and are not able to overcome the negative potential  $V_{GA}$  and the anode current decreases. The potential  $V_{GK}$  at the decrease is equal to the first excitation potential of the atom.

### Operating Principle

In the present ionization potential measurement, the traditional Franck-Hertz set-up as described above has been altered to detect the threshold for ionizing inelastic collisions. The experimental tube is a tetrode filled with argon, the experimental substance. Figure 1 shows the basic circuit diagram. The electrons emitted by the heated filament are accelerated by the potential  $V_{G2K}$  between the cathode and the grid  $G_2$ . The grid  $G_1$  helps in minimizing space charge effects. Both the grids consist of wire mesh and allow the electrons to pass through. The anode A is maintained at a potential slightly negative with respect to the cathode. The electrons are never able to reach it. It is ready to receive positive ions if they have been created in the tube. The on-set of anode current therefore signifies the creation of positive ions, i.e. the on-set of ionizing inelastic collisions between the electrons and the argon atoms. In the experiment the electron current is measured as a function of the voltage  $V_{G2K}$ . As this voltage increases, the electron energy goes up. But as long as this energy is less

than what is required to ionize the atom, the ions are not created, and the anode current remains equal to zero. The inelastic collisions leading to the excitation of argon atoms are immaterial because no ions are created there in and the anode current remains unaffected. The potential  $V_{G2K}$  at the on-set of the anode current is equal to the ionization potential. As  $V_{G2K}$  further increases, more and more electrons undergo ionizing collisions and the anode current increases. When  $V_{G2K}$  reaches a value twice that of the ionization potential, it is possible for an electron to ionize an atom half way between the grid and the cathode, lose all its energy, and then gain anew enough energy to ionize another argon atom. The anode current beginning at this value of  $V_{G2K}$  shows a faster increase with  $V_{G2K}$  as now there is a larger number of ions reaching the anode.

### Ionization Potential Set-up, Model IP-001,

consists of the following:

- a) Argon filled tetrode
- b) Filament Power Supply
- c) Power Supply for  $V_{G1K}$
- d) Power Supply for  $V_{KA}$
- e) Power Supply for  $V_{G2K}$
- f) Saw tooth wave form for CRO display
- g) Multirange Voltmeter
- h) Multirange Ammeter

All this is housed in a cabinet with meters and adjustment knobs on the front panel. The set-up can also directly display the anode current variation with  $V_{G2K}$  on the oscilloscope screen. It can thus be used as a laboratory experiment as well as for demonstration to a group of students.

### ANALYSIS OF THE DATA

Point by point data for the anode current with  $V_{G2K}$  changing in steps of 1 V at  $V_{G1K}$  equal to 1.5 V and  $V_{KA}$  equal to 3.0 V are shown in Figure 2. The on-set of the anode current and the point where the slope of the current changes can be determined by locating the points of intersection of the lines as shown in Figure 2. These points are at 16 V and 31 V respectively. The former corresponds to the ionization potential and the later for the ionization again. The average value of the ionization potential thus found is 15.5 eV compared with the accepted value of 15.6 eV.

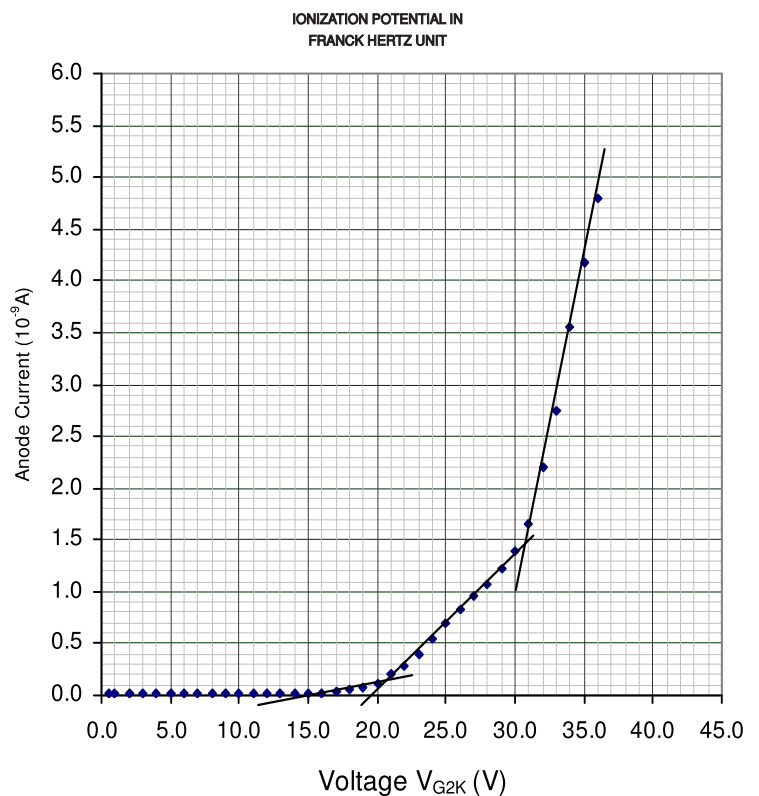

Figure 2 Plot of Anode Current vs  $V_{G2K}$  in the Ionization Potential Set-up

# DFP-02

## Four Probe Method (Basic Model)

### Resistivity of Semiconductor by Four Probe Method at different temperatures and determination of the Band-gap

The Four Probe Method is one of the standard and most widely used method for the measurement of resistivity of semiconductors. The experimental arrangement is illustrated. In its useful form, the four probes are collinear. The error due to contact resistance, which is specially serious in the electrical measurement on semiconductors, is avoided by the use of two extra contacts

(probes) between the current contacts. In this arrangement the contact resistance may all be high compare to the sample resistance, but as long as the resistance of the sample and contact resistances are small compared with the effective resistance of the voltage measuring device (potentiometer, electrometer or electronic voltmeter), the measured value will remain unaffected. Because of pressure contacts, the arrangement is also specially useful for quick measurement on different samples or sampling different parts of the same sample.

#### Description of the experimental set-up

##### 1. Probes Arrangement

It has four individually spring loaded probes. The probes are collinear and equally spaced. The probes are mounted in a teflon bush, which ensure a good electrical insulation between the probes. A teflon spacer near the tips is also provided to keep the

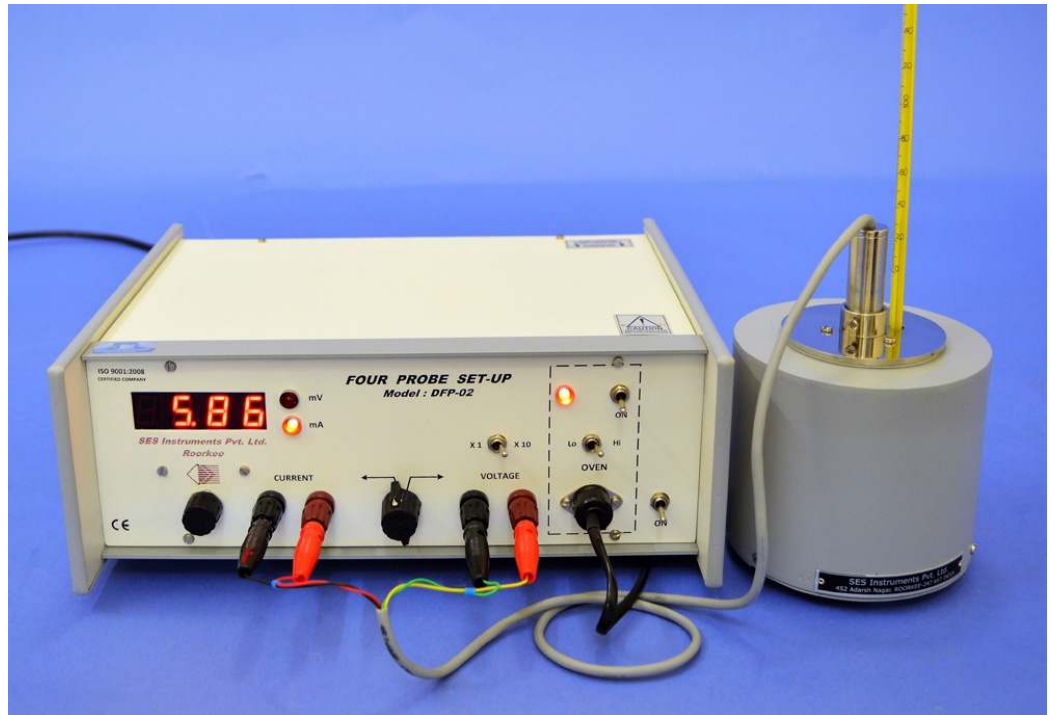

probes at equal distance. The whole - arrangement is mounted on a suitable stand and leads are provided for the voltage measurement.

##### 2. Sample

Germanium crystal in the form of a chip (10X9X0.5mm)

##### 3. Oven

It is a small oven for the variation of temperature of the crystal from the room temperature to about 200°C (max.)



### 4. Four Probe Set-up, DFP-02

The set-up consists of three units in the same cabinet.

#### (i) Multirange Digital Voltmeter

In this unit, intersil 3½ digit single chip A/D Converter ICL 7107 has been used. It has high accuracy like auto zero to less than 10µV, zero drift of less than 1µV/ °C, input bias current of 10pA max. and roll-over error of less than one count. Since the use of internal reference causes the degradation in performance due to internal heating, an external reference has been used.

#### Specifications

Range : X1 (0-200mV) & X10 (0-2V)

Impedance : MΩ

Resolution : 100µV at X1 range

Display : 3½ digit, 7 segment LED (12.5mm height) with polarity and decimal indication

Accuracy : ±0.1% of reading ±1 digit

Overload Indicator : Sign of 1 on the left & blanking of other digits

#### (ii) Constant Current Generator

It is an IC regulated current generator to provide a constant current to the outer probes irrespective of the changing resistance of the sample due to change in temperatures. The basic scheme is to use the feedback principle to limit the load current

of the supply to preset maximum value Variations in the current are achieved by a potentiometer included for that purpose. The supply a highly regulated and practically ripple free d.c. source. The current is measured by the digital panel meter.

#### Specifications

Open Circuit Voltage : 18V

Current range : 0-20mA

Resolution : 10µA

Accuracy : ±0.25% of the reading ±1 digit

Load regulation : 0.03% for 0 to full load

Line Regulation : 0.05% for 10% changes

(iii) Oven Power Supply Suitable voltage for the oven is obtained through a step down transformer with a provision for low and high rates of heating. A glowing LED indicates, when the oven power supply is 'ON'.

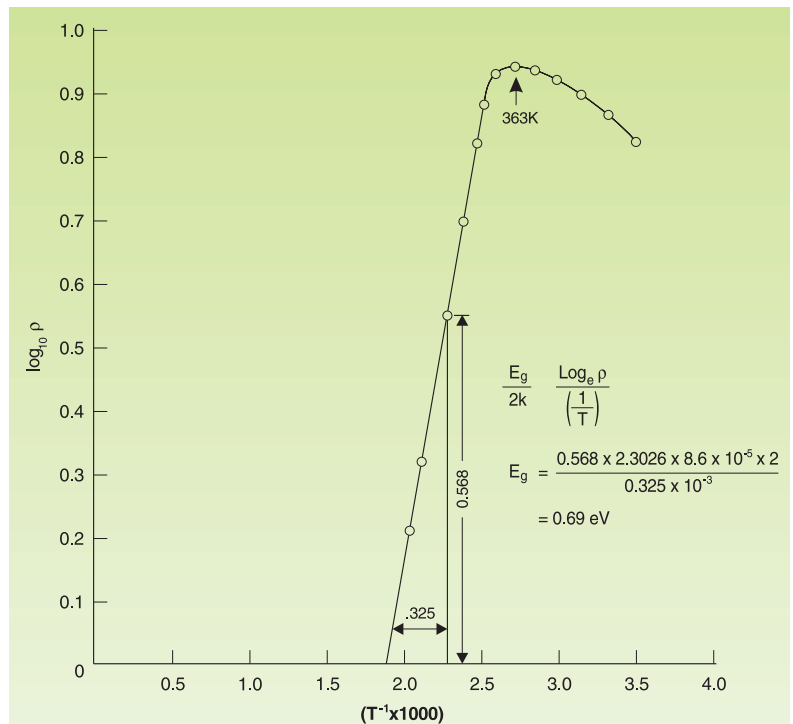
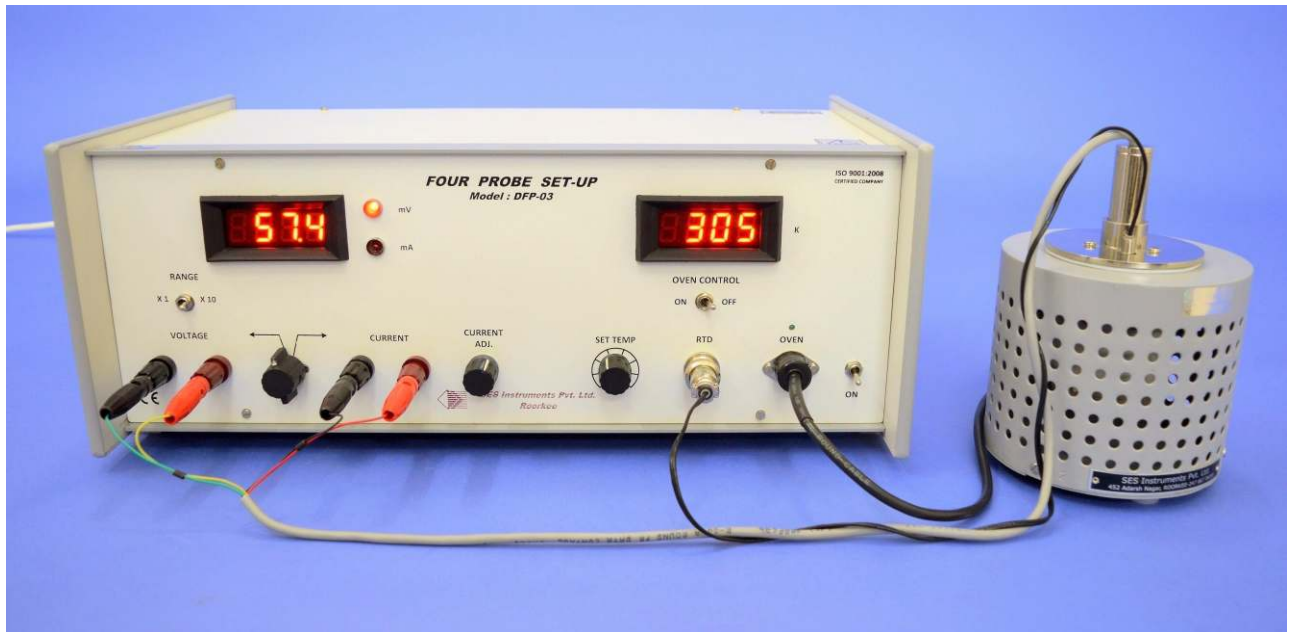

**Fig. The resistivity of a Germanium crystal as a function of inverse temperature.**  
 For this sample  $T < 363\text{K}$ , conduction is due mainly to the impurity carriers (Extrinsic Region). For  $T > 363\text{K}$ , conduction is due to electrons transferred to the conduction band (and the corresponding holes created in the valence band). This is the Intrinsic region.

The experimental setup is complete in all respect

# DFP-03

## Four Probe Method (Advance Model)



### Resistivity of Semiconductor by Four Probe Method at different temperatures and determination of the band-gap

The Four Probe Method is one of the standard and most widely used method for the measurement of resistivity. In its useful form, the four probes are collinear. The error due to contact resistance, which is significant in the electrical measurement on semiconductors, is avoided by the use of two extra contacts (probes) between the current contacts. In this arrangement the contact resistance may all be high compare to the sample resistance, but as long as the resistance of the sample and contact resistance's are small compared with the effective resistance of the voltage measuring device (potentiometer, electrometer or electronic voltmeter), the measured value will remain unaffected. Because of pressure contacts, the arrangement is also specially useful for quick measurement on different samples or sampling different parts of the sample.

### Description of the experimental set-up

#### 1. Probes Arrangement

It has four individually spring loaded probes. The probes are collinear and equally spaced. The probes are mounted in a teflon bush, which ensure a good electrical insulation between the probes. A teflon spacer near the tips is also provided to keep the probes at equal distance. The probe arrangement is mounted in a suitable stand, which also hold the sample plate. To ensure the correct measurement of sample temperature, the FITD is embeded in the sample plate just below the sample. This stand also serves as the lid of temperature controlled oven. Proper leads are provided for the current and voltage measurement.

#### 2. SAMPLE

Germanium crystal in the form of a chip (10X9X0.5mm).

#### 3. OVEN

This is high quality temperature controlled oven suitable for Four Probe Set-up. The oven has been designed for fast heating and cooling rates, which enhances the effectiveness of the controller.

### 4. Four Probe SET-UP, DFP-03

The set-up consists of three units housed in the same cabinet.

#### (i) Oven Controller

Platinum RTD (A class) has been used for sensing the temperature. A wheatstone bridge and an instrumentation amplifier are used for signal conditioning. Feedback circuit ensures offset and linearity trimming and a fast accurate control of the oven temperature.

#### Specifications of the Oven

Temperature Range	: Ambient to 473K
Resolution	: 1K
Stability	: $\pm 0.5K$
Measurement Accuracy	: $\pm 1K$ (typical)
Oven	: Specially designed for Four Probe Set-Up
Sensor	: RTD (A class)
Display	: 3½ digit, 7 segment LED with autopolarity and decimal indication
Power	: 150W

#### (i) Multirange Digital Voltmeter

In this unit, intersil 3½ digit single chip A/D Converter ICL 7107 has been used. It has accuracy, auto zero to less than 10  $\mu V$ , zero drift-less than 1  $\mu V/^\circ C$ , input bias current of 10 pA and roll over error of less than one count. Since the use of internal reference causes the degradation in performance due to internal heating, an external reference has been used.

#### Specification

Range	: X1 (0-200mV) & X10 (0-2V)
Resolution	: 100 $\mu V$ at X 1 range
Accuracy	: $\pm 0.1\%$ of reading $\pm 1$ digit
Display	: 3½ digit, 7 segment LED with autopolarity and decimal indication
Overload Indicator	: Sign of 1 on the left & blanking of other digits.

#### (ii) Constant Current Generator

It is an IC regulated current generator to provide a constant current to the outer probes irrespective of the changing resistance of the sample due to change in temperatures. The basic scheme is to use the feedback principle to limit the load current of the supply to preset maximum value. Variations in the current are achieved by a potentiometer included for that purpose. The supply is a highly regulated and practically ripple free d.c. source. The current is measured by the digital panel meter.

#### Specification

Open circuit voltage	: 18 V
Accuracy	: $\pm 0.25\%$ of the reading $\pm 1$ digit
Current range	: 0-20 mA
Load regulation	: 0.05% for 0 to full load
Resolution	: 10 $\mu A$
Line regulation	: 0.05% for 10% changes

Typical results obtained from this set-up are shown in the graph.

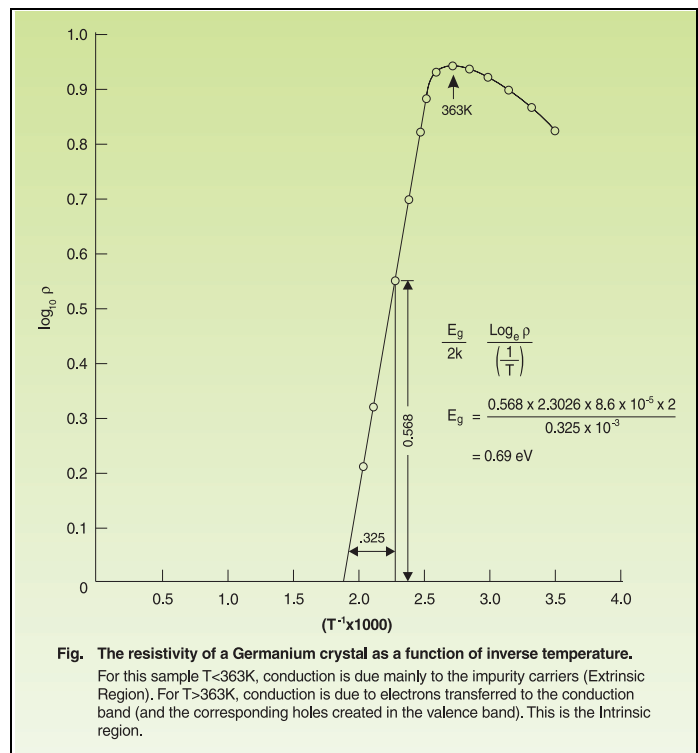

The experimental set-up is complete in all respect

# Four Probe Setup

DFP-RM-200N

SES Instruments Pvt Ltd.

Four Probe Set-Up for measuring the resistivity of very low to highly resistive thin sheet samples at different temperatures

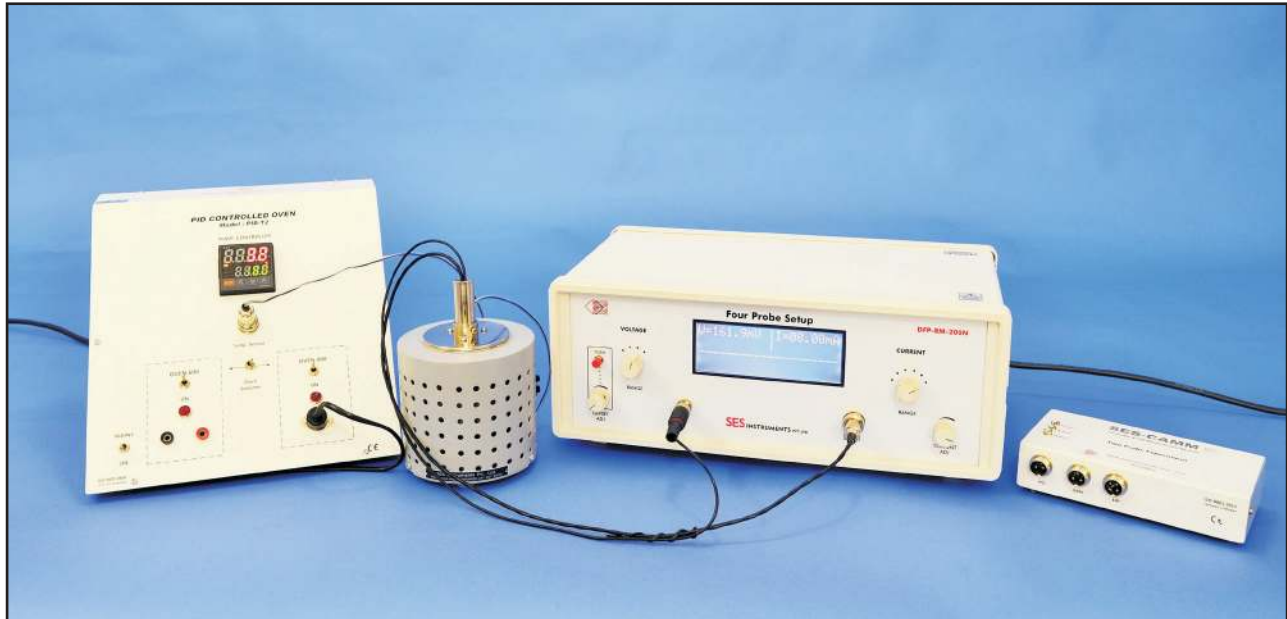

## Description

The Four Probe Method is one of the standard and most widely used method for the measurement of resistivity. In its useful form, the four probes are collinear. The error due to contact resistance, which is significant in the electrical measurement on semiconductors, is avoided by the use of two extra contacts (probes) between the current contacts. In this arrangement the contact resistance may all be high compare to the sample resistance, but as long as the resistance of the sample and contact resistance's are small compared with the effective resistance of the voltage measuring device (potentiometer, electrometer or electronic voltmeter), the measured value will remain unaffected. Because of pressure contacts, the arrangement is also specially useful for quick measurement on different samples or sampling different parts of the sample.

## Description of Experimental Set-up

### 1. Probes Arrangement

It has four individually spring loaded probes. The probes are collinear and equally spaced. The probes are mounted in a teflon bush, which ensure a good electrical insulation between the probes. A teflon spacer near the tips is also provided to keep the probes at equal distance. The probe arrangement is mounted in a suitable stand, which also holds the sample plate and thermocouple sensor. This stand also serves as the lid of PID Controlled Oven. Proper leads are provided for the current and voltage measurements.

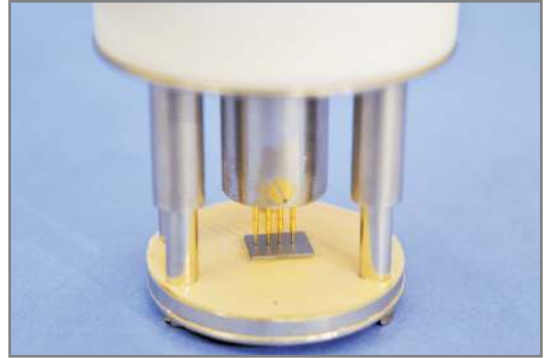

### 2. PID Controlled Oven

The unit is a high quality PID controller wherein the temperatures can be set and controlled easily. The P, I and D parameters are factory set for immediate use however the user may adjust these for specific applications as well as autotune the oven whenever required. The steps for these are given in the user manual. Although the controller may be used either for our small oven, up to 200°C or a larger oven up to 600°C, however, in the present setup only small oven is to be used. The controller uses thermocouple as temperature sensor.

#### Specifications of the Temperature Controller

The controller is designed around Autonics Temperature Controller Model TZN4S. Although this is a very versatile piece of equipment, below is a summary of the specifications that are relevant to the present application. The PID parameters are factory set to a reasonable level (P = 1.8; I = 300; D = 80) for immediate operation of the unit.

- Temperature Range: -190°C to 200°C
- Oven: Specially designed for Four Probe Set-Up
- Display Accuracy:  $\pm 0.3^\circ\text{C}$
- Sensor: Thermocouple (Chromel-Alumel)
- Setting Type: Front push buttons
- Display: 7 segment LED, two rows
- Control Method: PID, PIDF, PIDS
- Values: Process Value, PV and Set Value, SV
- Temperature control range: Ambient to 200°C
- Power: 150W



### 3. Control Unit of Four Probe Setup

The unit comprises of two sections – a totally isolated constant current source, and a grounded voltage measurement system. Features of these two sections are described below in some detail.

#### (A) Constant Current Source

It is an IC regulated current generator that is galvanically isolated from the rest of the circuit which is a basic requirement of four probe method. The isolation is achieved by using an optically coupled amplifier and associated circuits. This circuit sends a constant Current. To the changing resistance of the sample due to change in temp..



A judicious choice of the current setting as detailed in the user manual is necessary depending on the resistance value that is measured. Brief technical details of the current section are as under:

- Current Range: 2 $\mu$ A, 20 $\mu$ A, 200 $\mu$ A, 2mA, 20mA and 200mA with over ranging
- Open Circuit Voltage: 30V
- Accuracy :  $\pm 0.25\%$  of the reading  $\pm 1$  digit
- 4-line LCD display with indication when current needs decreasing

#### (b) Digital Voltmeter Section

The voltmeter is used to read the voltage developed between the middle pins of the four probe arrangement. A primary requirement is to have very high input resistance so that the measurement is not disturbed in case of high resistance samples. The input range of the voltmeter is thus limited by avoiding the use of any potential divider. Brief technical details are as under:

- Voltage Range: 2mV, 20 mV, 200 mV, 2V with over ranging
- Manual adjustment of Offset Voltage whenever current/voltage range is changed
- Accuracy :  $\pm 0.25\%$  of the reading  $\pm 1$  digit
- 4-line LCD display with over voltage indication

*In addition to the above, the Four Probe Setup as well as the PID Oven Unit may be connected to a computer for data logging purposes. Necessary hardware and software are included in the system.*

# Four Probe Setup

DFP-RM-200NC

SES Instruments Pvt Ltd.

Four Probe Set-Up for measuring the resistivity of very low to highly resistive thin sheet samples at different temperatures

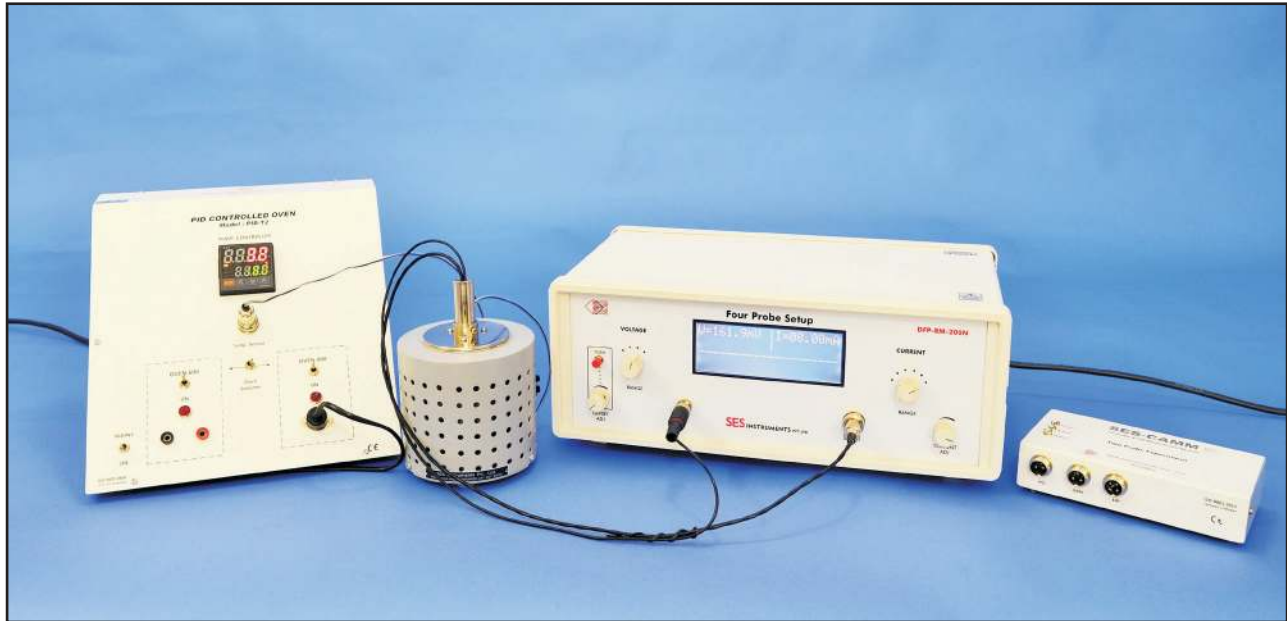

## Description

The Four Probe Method is one of the standard and most widely used method for the measurement of resistivity. In its useful form, the four probes are collinear. The error due to contact resistance, which is significant in the electrical measurement on semiconductors, is avoided by the use of two extra contacts (probes) between the current contacts. In this arrangement the contact resistance may all be high compare to the sample resistance, but as long as the resistance of the sample and contact resistance's are small compared with the effective resistance of the voltage measuring device (potentiometer, electrometer or electronic voltmeter), the measured value will remain unaffected. Because of pressure contacts, the arrangement is also specially useful for quick measurement on different samples or sampling different parts of the sample.

## Description of Experimental Set-up

### 1. Probes Arrangement

It has four individually spring loaded probes. The probes are collinear and equally spaced. The probes are mounted in a teflon bush, which ensure a good electrical insulation between the probes. A teflon spacer near the tips is also provided to keep the probes at equal distance. The probe arrangement is mounted in a suitable stand, which also holds the sample plate and thermocouple sensor. This stand also serves as the lid of PID Controlled Oven. Proper leads are provided for the current and voltage measurements.

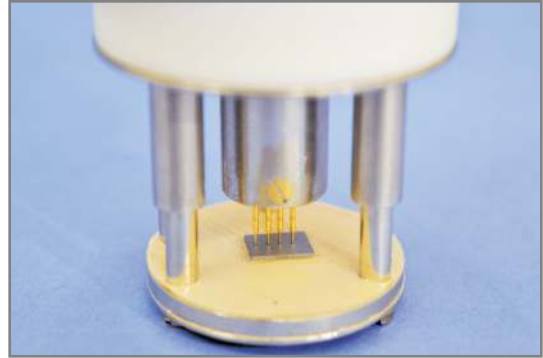

### 2. PID Controlled Oven

The unit is a high quality PID controller wherein the temperatures can be set and controlled easily. The P, I and D parameters are factory set for immediate use however the user may adjust these for specific applications as well as autotune the oven whenever required. The steps for these are given in the user manual. Although the controller may be used either for our small oven, up to 200°C or a larger oven up to 600°C, however, in the present setup only small oven is to be used. The controller uses thermocouple as temperature sensor.

#### Specifications of the Temperature Controller

The controller is designed around Autonics Temperature Controller Model TZN4S. Although this is a very versatile piece of equipment, below is a summary of the specifications that are relevant to the present application. The PID parameters are factory set to a reasonable level (P = 1.8; I = 300; D = 80) for immediate operation of the unit.

- Temperature Range: -190°C to 200°C
- Oven: Specially designed for Four Probe Set-Up
- Display Accuracy:  $\pm 0.3^\circ\text{C}$
- Sensor: Thermocouple (Chromel-Alumel)
- Setting Type: Front push buttons
- Display: 7 segment LED, two rows
- Control Method: PID, PIDF, PIDS
- Values: Process Value, PV and Set Value, SV
- Temperature control range: Ambient to 200°C
- Power: 150W



### 3. Control Unit of Four Probe Setup

The unit comprises of two sections – a totally isolated constant current source, and a grounded voltage measurement system. Features of these two sections are described below in some detail.

#### (A) Constant Current Source

It is an IC regulated current generator that is galvanically isolated from the rest of the circuit which is a basic requirement of four probe method. The isolation is achieved by using an optically coupled amplifier and associated circuits. This circuit sends a constant Current. To the changing resistance of the sample due to change in temp..



A judicious choice of the current setting as detailed in the user manual is necessary depending on the resistance value that is measured. Brief technical details of the current section are as under:

- Current Range: 2 $\mu$ A, 20 $\mu$ A, 200 $\mu$ A, 2mA, 20mA and 200mA with over ranging
- Open Circuit Voltage: 30V
- Accuracy :  $\pm 0.25\%$  of the reading  $\pm 1$  digit
- 4-line LCD display with indication when current needs decreasing

#### (b) Digital Voltmeter Section

The voltmeter is used to read the voltage developed between the middle pins of the four probe arrangement. A primary requirement is to have very high input resistance so that the measurement is not disturbed in case of high resistance samples. The input range of the voltmeter is thus limited by avoiding the use of any potential divider. Brief technical details are as under:

- Voltage Range: 2mV, 20 mV, 200 mV, 2V with over ranging
- Manual adjustment of Offset Voltage whenever current/voltage range is changed
- Accuracy :  $\pm 0.25\%$  of the reading  $\pm 1$  digit
- 4-line LCD display with over voltage indication

*In addition to the above, the Four Probe Setup as well as the PID Oven Unit may be connected to a computer for data logging purposes. Necessary hardware and software are included in the system.*

# Four Probe Setup

DFP-LHN

SES Instruments Pvt Ltd.

## Four Probe Set-Up for Measuring the Resistivity of Different Samples at Different Temperature from -170 to 200C



### Description

The Four Probe Method is one of the standard and most widely used method for the measurement of resistivity. In its useful form, the four probes are collinear. The error due to contact resistance, which is significant in the electrical measurement on semiconductors, is avoided by the use of two extra contacts (probes) between the current contacts. In this arrangement the contact resistance may all be high compare to the sample resistance, but as long as the resistance of the sample and contact resistance's are small compared with the effective resistance of the voltage measuring device (potentiometer, electrometer or electronic voltmeter), the measured value will remain unaffected. Because of pressure contacts, the arrangement is also specially useful for quick measurement on different samples or sampling different parts of the sample.

## Description of Experimental Set-up

### 1. Probes Arrangement

It has four individually spring loaded probes. The probes are collinear and equally spaced. The probes are mounted in a teflon bush, which ensure a good electrical insulation between the probes. A teflon spacer near the tips is also provided to keep the probes at equal distance. The probe arrangement is mounted in a suitable stand, which also holds the sample plate and Thermocouple sensor. This stand also serves as the lid of PID Controlled Oven. Proper leads are provided for the current and voltage measurements.

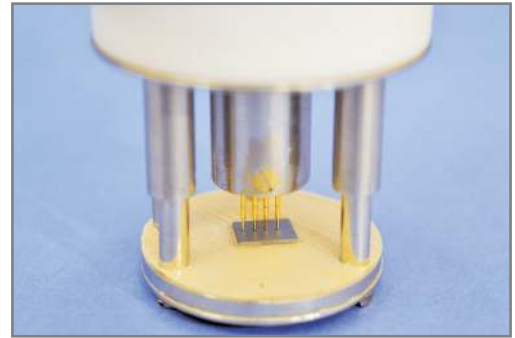

### 2. PID Controlled Oven cum Cryostat

In this unit heating of sample zone is done through heating coil and cooling through controlled flow of liquid nitrogen. The necessary components such as the cryostat, the flow system etc. are included. Temperature range is from  $-170^{\circ}\text{C}$  to  $200^{\circ}\text{C}$ . The unit is a high quality PID controller wherein the temperatures can be set and controlled easily. The P, I and D parameters are factory set for immediate use however the user may adjust these for specific applications as well as auto-tune the oven whenever required. The steps for these are given in the user manual.

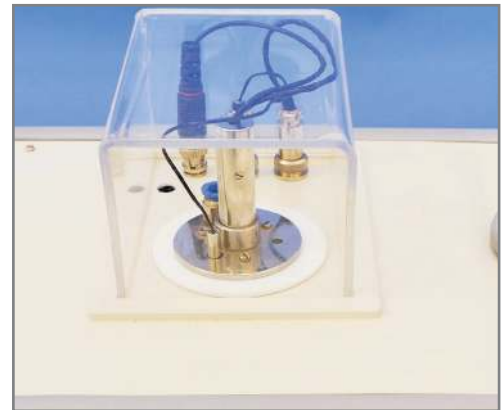

### Specifications of the Temperature Controller

The controller is designed around Autonics Temperature Controller Model TK4S. Although this is a very versatile piece of equipment, below is a summary of the specifications that are relevant to the present application.

- Temperature Range:  $-170^{\circ}\text{C}$  to  $200^{\circ}\text{C}$
- Oven: Specially designed for Four Probe Set-Up
- Display Accuracy:  $\pm 0.3^{\circ}\text{C}$
- Sensor: Thermocouple (Chromel-Alumel)
- Setting Type: Front push buttons
- Display: 7 segment LED, two rows
- Control Method: PID, PIDF, PIDS
- Values: Process Value, PV and Set Value, SV
- Temperature control range: Ambient to  $200^{\circ}\text{C}$
- Power: 150W



### 3. Control Unit of Four Probe Setup

The unit comprises of two sections – a totally isolated constant current source, and a grounded voltage measurement system. Features of these two sections are described below in some detail.

#### (A) Constant Current Source

It is an IC regulated current generator that is galvanically isolated from the rest of the circuit which is a basic requirement of four probe method. The isolation is achieved by using an optically coupled amplifier and associated circuits. This circuit sends a constant Current. To the changing resistance of the sample due to change in temp..



A judicious choice of the current setting as detailed in the user manual is necessary depending on the resistance value that is measured. Brief technical details of the current section are as under:

- Current Range: 2 $\mu$ A, 20 $\mu$ A, 200 $\mu$ A, 2mA, 20mA and 200mA with over ranging
- Open Circuit Voltage: 30V
- Accuracy :  $\pm 0.25\%$  of the reading  $\pm 1$  digit
- 4-line LCD display with indication when current needs decreasing

#### (b) Digital Voltmeter Section

The voltmeter is used to read the voltage developed between the middle pins of the four probe arrangement. A primary requirement is to have very high input resistance so that the measurement is not disturbed in case of high resistance samples. The input range of the voltmeter is thus limited by avoiding the use of any potential divider. Brief technical details are as under:

- Voltage Range: 2mV, 20 mV, 200 mV, 2V with over ranging
- Manual adjustment of Offset Voltage whenever current/voltage range is changed
- Accuracy :  $\pm 0.25\%$  of the reading  $\pm 1$  digit
- 4-line LCD display with over voltage indication

*In addition to the above, the Four Probe Setup as well as the PID Oven cum Cryostate Unit may be connected to a computer for data logging purposes. Necessary hardware and software are optional and available separately.*

**The setup is complete in itself**

# Four Probe Setup

DFP-LHC

SES Instruments Pvt Ltd.

## Four Probe Set-Up for Measuring the Resistivity of Different Samples at Different Temperature from -170 to 200C



### Description

The Four Probe Method is one of the standard and most widely used method for the measurement of resistivity. In its useful form, the four probes are collinear. The error due to contact resistance, which is significant in the electrical measurement on semiconductors, is avoided by the use of two extra contacts (probes) between the current contacts. In this arrangement the contact resistance may all be high compare to the sample resistance, but as long as the resistance of the sample and contact resistance's are small compared with the effective resistance of the voltage measuring device (potentiometer, electrometer or electronic voltmeter), the measured value will remain unaffected. Because of pressure contacts, the arrangement is also specially useful for quick measurement on different samples or sampling different parts of the sample.



## Description of Experimental Set-up

### 1. Probes Arrangement

It has four individually spring loaded probes. The probes are collinear and equally spaced. The probes are mounted in a teflon bush, which ensure a good electrical insulation between the probes. A teflon spacer near the tips is also provided to keep the probes at equal distance. The probe arrangement is mounted in a suitable stand, which also holds the sample plate and Thermocouple sensor. This stand also serves as the lid of PID Controlled Oven. Proper leads are provided for the current and voltage measurements.

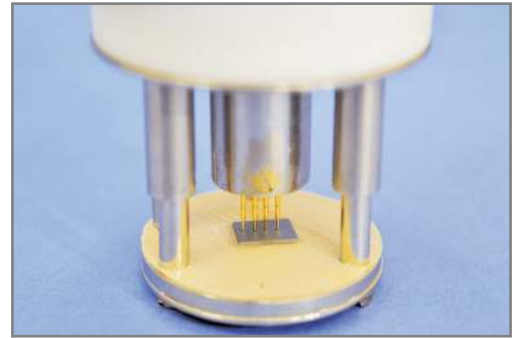

### 2. PID Controlled Oven cum Cryostat

In this unit heating of sample zone is done through heating coil and cooling through controlled flow of liquid nitrogen. The necessary components such as the cryostat, the flow system etc. are included. Temperature range is from  $-170^{\circ}\text{C}$  to  $200^{\circ}\text{C}$ . The unit is a high quality PID controller wherein the temperatures can be set and controlled easily. The P, I and D parameters are factory set for immediate use however the user may adjust these for specific applications as well as auto-tune the oven whenever required. The steps for these are given in the user manual.

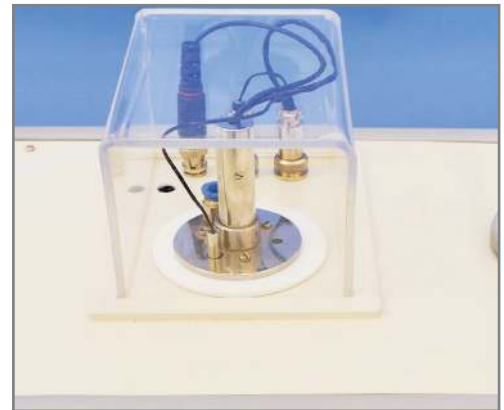

### Specifications of the Temperature Controller

The controller is designed around Autonics Temperature Controller Model TK4S. Although this is a very versatile piece of equipment, below is a summary of the specifications that are relevant to the present application.

- Temperature Range:  $-170^{\circ}\text{C}$  to  $200^{\circ}\text{C}$
- Oven: Specially designed for Four Probe Set-Up
- Display Accuracy:  $\pm 0.3^{\circ}\text{C}$
- Sensor: Thermocouple (Chromel-Alumel)
- Setting Type: Front push buttons
- Display: 7 segment LED, two rows
- Control Method: PID, PIDF, PIDS
- Values: Process Value, PV and Set Value, SV
- Temperature control range: Ambient to  $200^{\circ}\text{C}$
- Power: 150W



### 3. Control Unit of Four Probe Setup

The unit comprises of two sections – a totally isolated constant current source, and a grounded voltage measurement system. Features of these two sections are described below in some detail.

#### (A) Constant Current Source

It is an IC regulated current generator that is galvanically isolated from the rest of the circuit which is a basic requirement of four probe method. The isolation is achieved by using an optically coupled amplifier and associated circuits. This circuit sends a constant Current. To the changing resistance of the sample due to change in temp..



A judicious choice of the current setting as detailed in the user manual is necessary depending on the resistance value that is measured. Brief technical details of the current section are as under:

- Current Range: 2 $\mu$ A, 20 $\mu$ A, 200 $\mu$ A, 2mA, 20mA and 200mA with over ranging
- Open Circuit Voltage: 30V
- Accuracy :  $\pm 0.25\%$  of the reading  $\pm 1$  digit
- 4-line LCD display with indication when current needs decreasing

#### (b) Digital Voltmeter Section

The voltmeter is used to read the voltage developed between the middle pins of the four probe arrangement. A primary requirement is to have very high input resistance so that the measurement is not disturbed in case of high resistance samples. The input range of the voltmeter is thus limited by avoiding the use of any potential divider. Brief technical details are as under:

- Voltage Range: 2mV, 20 mV, 200 mV, 2V with over ranging
- Manual adjustment of Offset Voltage whenever current/voltage range is changed
- Accuracy :  $\pm 0.25\%$  of the reading  $\pm 1$  digit
- 4-line LCD display with over voltage indication

*In addition to the above, the Four Probe Setup as well as the PID Oven cum Cryostate Unit may be connected to a computer for data logging purposes. Necessary hardware and software are included in the system.*

***The setup is complete in itself***

# Four Probe Setup

FP-01

SES Instruments Pvt Ltd.

## Four Probe Set-Up for Measuring the Resistivity of Different Samples at Different Temperature from -170 to 200C



### Description

The Four Probe Method is one of the standard and most widely used method for the measurement of resistivity. In its useful form, the four probes are collinear. The error due to contact resistance, which is significant in the electrical measurement on semiconductors, is avoided by the use of two extra contacts (probes) between the current contacts. In this arrangement the contact resistance may all be high compare to the sample resistance, but as long as the resistance of the sample and contact resistance's are small compared with the effective resistance of the voltage measuring device (potentiometer, electrometer or electronic voltmeter), the measured value will remain unaffected. Because of pressure contacts, and 2 way motion, the arrangement is specially useful for quick measurement on large samples at room temperature.

## Description of Experimental Set-up

### 1. Probes Arrangement

It has four individually spring loaded probes. The probes are collinear and equally spaced. The probes are mounted in a teflon bush, which ensure a good electrical insulation between the probes. A teflon spacer near the tips is also provided to keep the probes at equal distance. The probe arrangement is mounted in a tube, which also provide leads for connections to ConFour Probe Control Unit. The tube

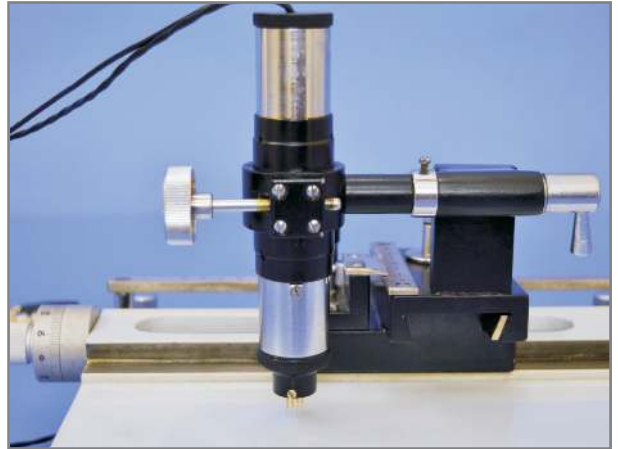

containing four probes is mounted on a travelling microscope type system, scales and verniers are made of stainless steels with following specification:

Horizontal: 20 cm least count 0.001 cm

Lateral : 6 cm least count 0.001 cm

Vertical : 15 cm least count 0.001 cm

The bed is of heavy casting, thoroughly aged and machined, is fitted with leveling screws. A large platform is provided for fixing the sample.

### 3. Control Unit of Four Probe Setup

The unit comprises of two sections – a totally isolated constant current source, and a grounded voltage measurement system. Features of these two sections are described below in some detail.

#### (A) Constant Current Source

It is an IC regulated current generator that is galvanically isolated from the rest of the circuit which is a basic requirement of four probe method. The isolation is achieved by using an optically coupled amplifier and associated circuits. This circuit sends a constant Current. To the changing resistance of the sample due to change in temp..



A judicious choice of the current setting as detailed in the user manual is necessary depending on the resistance value that is measured. Brief technical details of the current section are as under:

- Current Range: 2 $\mu$ A, 20 $\mu$ A, 200 $\mu$ A, 2mA, 20mA and 200mA with over ranging
- Open Circuit Voltage: 30V
- Accuracy :  $\pm 0.25\%$  of the reading  $\pm 1$  digit
- 4-line LCD display with indication when current needs decreasing

#### (b) Digital Voltmeter Section

The voltmeter is used to read the voltage developed between the middle pins of the four probe arrangement. A primary requirement is to have very high input resistance so that the measurement is not disturbed in case of high resistance samples. The input range of the voltmeter is thus limited by avoiding the use of any potential divider. Brief technical details are as under:

- Voltage Range: 2mV, 20 mV, 200 mV, 2V with over ranging
- Manual adjustment of Offset Voltage whenever current/voltage range is changed
- Accuracy :  $\pm 0.25\%$  of the reading  $\pm 1$  digit
- 4-line LCD display with over voltage indication

*In addition to the above, the Four Probe Setup as well as the PID Oven cum Cryostate Unit may be connected to a computer for data logging purposes. Necessary hardware and software are optional and available separately.*

***The setup is complete in itself***

# Four Probe Setup

FP-01C

SES Instruments Pvt Ltd.

## FOUR PROBE SET-UP FOR MAPPING THE RESISTIVITY OF LARGE SAMPLES



### Description

The Four Probe Method is one of the standard and most widely used method for the measurement of resistivity. In its useful form, the four probes are collinear. The error due to contact resistance, which is significant in the electrical measurement on semiconductors, is avoided by the use of two extra contacts (probes) between the current contacts. In this arrangement the contact resistance may all be high compare to the sample resistance, but as long as the resistance of the sample and contact resistance's are small compared with the effective resistance of the voltage measuring device (potentiometer, electrometer or electronic voltmeter), the measured value will remain unaffected. Because of pressure contacts, and 2 way motion, the arrangement is specially useful for quick measurement on large samples at room temperature.

## Description of Experimental Set-up

### 1. Probes Arrangement

It has four individually spring loaded probes. The probes are collinear and equally spaced. The probes are mounted in a teflon bush, which ensure a good electrical insulation between the probes. A teflon spacer near the tips is also provided to keep the probes at equal distance. The probe arrangement is mounted in a tube, which also provide leads for connections to ConFour Probe Control Unit. The tube

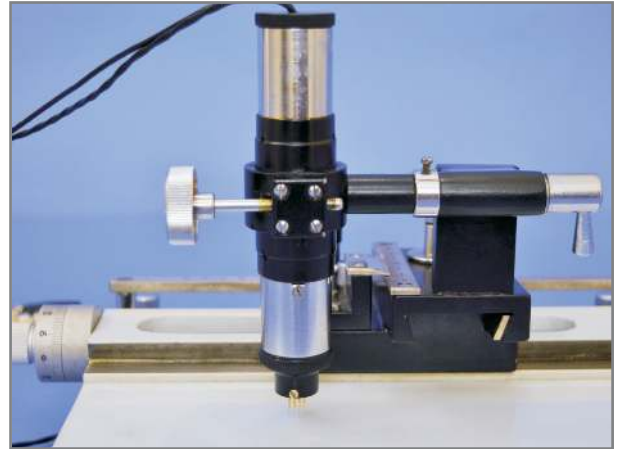

containing four probes is mounted on a travelling microscope type system, scales and verniers are made of stainless steels with following specification:

Horizontal: 20 cm least count 0.001 cm

Lateral : 6 cm least count 0.001 cm

Vertical : 15 cm least count 0.001 cm

The bed is of heavy casting, thoroughly aged and machined, is fitted with leveling screws. A large platform is provided for fixing the sample.

### 3. Control Unit of Four Probe Setup

The unit comprises of two sections – a totally isolated constant current source, and a grounded voltage measurement system. Features of these two sections are described below in some detail.

#### (A) Constant Current Source

It is an IC regulated current generator that is galvanically isolated from the rest of the circuit which is a basic requirement of four probe method. The isolation is achieved by using an optically coupled amplifier and associated circuits. This circuit sends a constant Current. To the changing resistance of the sample due to change in temp..



A judicious choice of the current setting as detailed in the user manual is necessary depending on the resistance value that is measured. Brief technical details of the current section are as under:

- Current Range: 2 $\mu$ A, 20 $\mu$ A, 200 $\mu$ A, 2mA, 20mA and 200mA with over ranging
- Open Circuit Voltage: 30V
- Accuracy :  $\pm 0.25\%$  of the reading  $\pm 1$  digit
- 4-line LCD display with indication when current needs decreasing

#### (b) Digital Voltmeter Section

The voltmeter is used to read the voltage developed between the middle pins of the four probe arrangement. A primary requirement is to have very high input resistance so that the measurement is not disturbed in case of high resistance samples. The input range of the voltmeter is thus limited by avoiding the use of any potential divider. Brief technical details are as under:

- Voltage Range: 2mV, 20 mV, 200 mV, 2V with over ranging
- Manual adjustment of Offset Voltage whenever current/voltage range is changed
- Accuracy :  $\pm 0.25\%$  of the reading  $\pm 1$  digit
- 4-line LCD display with over voltage indication

*In addition to the above, the Four Probe Setup as well as the PID Oven cum Cryostate Unit may be connected to a computer for data logging purposes. Necessary hardware and software are included in the system.*

***The setup is complete in itself***



# Van der Pauw Experiment

VDX-01

SES Instruments Pvt Ltd.

## Van der Pauw Set-Up for measurement of resistivity and determination of hall coefficients in semiconductor samples



### Introduction

Semiconductor material research and device testing often involve determining the resistivity and Hall mobility of a sample. The resistivity of the semiconductor material is often determined using a four-point probe technique. With a fourprobe, or Kelvin, technique, two of the probes are used to source current and the other two probes are used to measure voltage. Using four probes eliminates measurement errors due to the probe resistance, the spreading resistance under each probe, and the contact resistance between each metal probe and the semiconductor material. Because a high impedance voltmeter draws little current, the voltage drops across the probe resistance, spreading resistance, and contact resistance are very small. One common Kelvin technique for determining the resistivity of a semiconductor material is the van der Pauw (VDP) method. The van der Pauw method involves applying a current and measuring voltage using four small contacts on the circumference of a flat, arbitrarily shaped sample of uniform thickness. This method is particularly useful for measuring very small samples because geometric spacing of the contacts is unimportant. Effects

## Description of Experimental Set-up

### 1. Probes Arrangement

Ge single crystal with four pure silver, spring type pressure contacts is mounted on a sunmica coated bakelite strip. Suitable connector is provided for connections with current source and hall voltage measuring devices.

### 2. Van der Pauw Set-up, VDP-01

The set-up, VDP-01 consists of two sub units to handle probe current and hall voltage. While the probe current is generated and measured by a constant current source (0-20mA) having a resolution of  $10\mu\text{A}$ , the hall voltage is measured by a high input resistance millivoltmeter in the range 0-200mV having a resolution of  $100\mu\text{V}$ . The probe current and hall voltage are both displayed on separate 3.5 digit LED panel meters. Various combinations of Voltage and Current probe locations used in Van der Pauw measurements can be conveniently selected using bandswitch provided on the panel both for Resistivity and Hall Effect measurements.

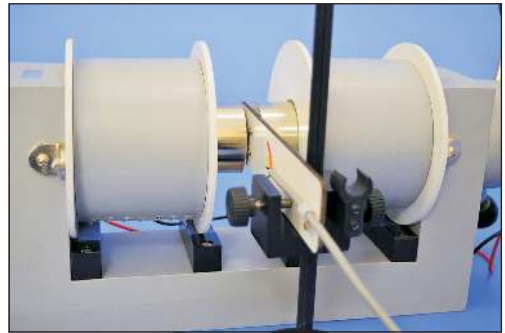
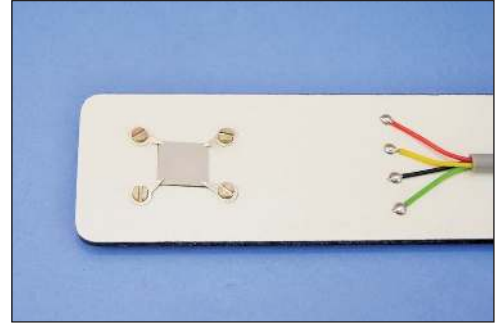

3. Electromagnet, EMU-50V (Refer datasheet for specifications)

4. Constant Current Power Supply, DPS-50 (Refer datasheet for specifications)

5. Digital Gaussmeter, DGM-202 (Refer datasheet for specifications)

***The setup is complete in itself***

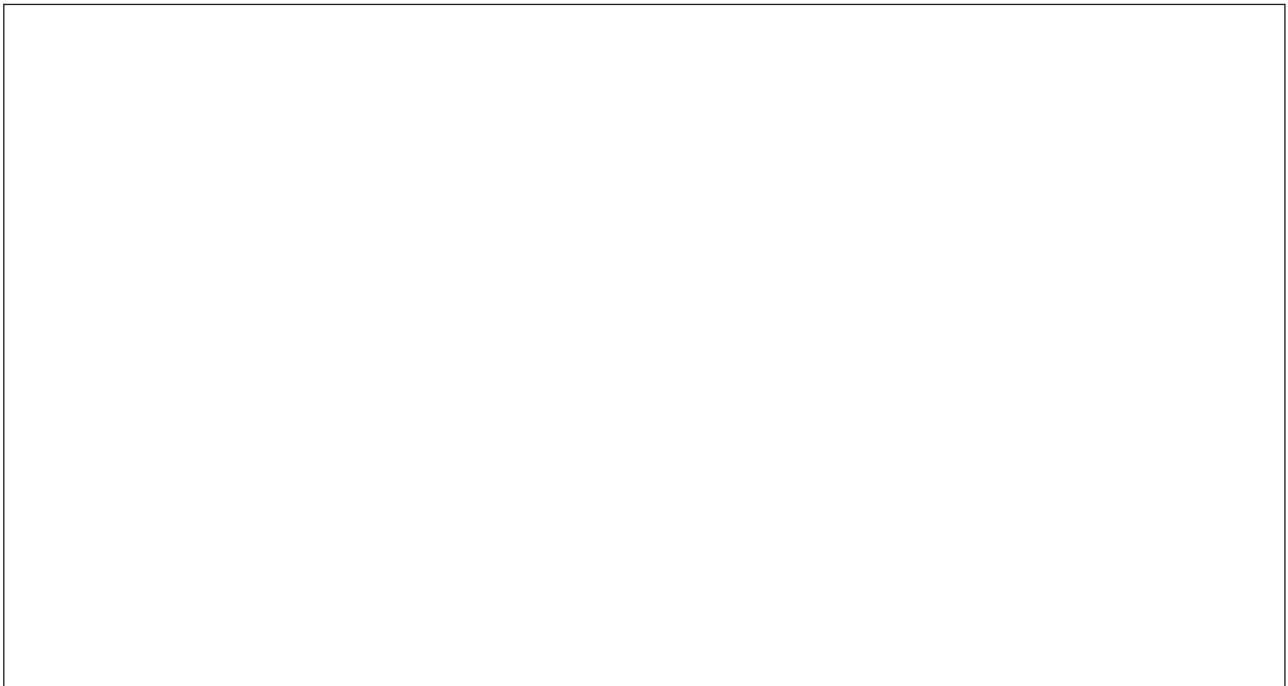

# MRX-01

## Measurement of Magnetoresistance of Semiconductors

### Measurement of Magnetoresistance of Semiconductors

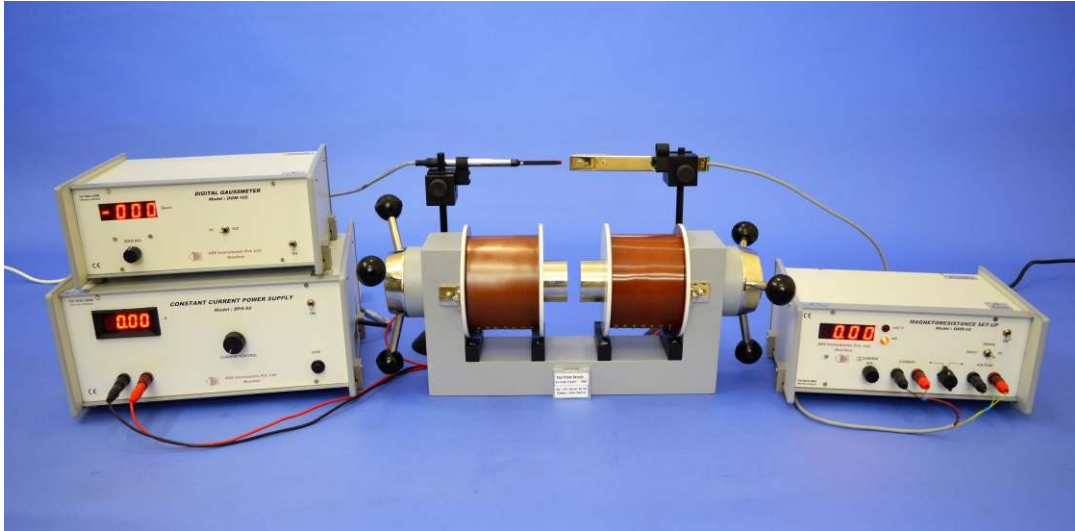

It is noticed that the resistance of the sample changes when the magnetic field is turned on. The phenomenon, called magnetoresistance, is due to the fact that the drift velocity of all carriers is not same. With the magnetic field on; the Hall voltage  $V = E_y t = |v \times H|$  compensates exactly the Lorentz force for carriers with the average velocity; slower carriers will be over compensated and faster one under compensated, resulting in trajectories that are not along the applied field. This results in an effective decrease of the mean free path and hence an increase in resistivity.

Here the above referred symbols are defines as:  $v$  = drift velocity;  $E$  = applied electric field;  $t$  = thickness of the crystal;  $H$  = Magnetic field.

#### Experimental Set-up for Magnetoresistance

The set-up consists of the following:

1. Four probe arrangement
2. Sample: (Ge: p-type)
3. Magnetoresistance set-up, DMR-01
4. Electromagnet, EMU-50V
5. Constant Current Power Supply, DPS-50
6. Digital Gaussmeter, DGM-102

#### (1) Four Probe arrangement°

It consists of 4 collinear, equally spaced (2mm) and individually spring loaded probes mounted on a PCB strip. Two outer probes for supplying the constant current to the sample and two inner probes for measuring the voltage developed across these probes This eliminates the error due to contact resistance which is particularly serious in semiconductors A platform is also provided for placing the sample and mounting the Four Probes on It.

#### (2) Sample

Ge Crystal (n-type) dimensions: 10 x 10 x 0.5mm.

#### (3) Magnetoresistance Set-up, Model DMR-01

This unit consists of a digital millivoltmeter and constant current power supply The voltage and probe current can be read on the same digital panel meter through a selector switch.

#### (a) Digital Millivoltmeter

Intersil 3½ digit single chip ICL 7107 have been used. Since the use of internal reference causes the degradation in performance due to internal heating an external reference have been used. Digital voltmeter is much more convenient to use, because the input voltage of either polarity can be measured.

# MRX-01

## Measurement of Magnetoresistance of Semiconductors

Page-2

### Specifications

Range : 0-200mV (100 $\mu$ V minimum)  
Accuracy :  $\pm 0.1\%$  of reading  $\pm 1$  digit

### (b) Constant Current Power Supply

This power supply, specially designed for Hall Probe, provides 100% protection against crystal burn-out due to excessive current. The supply is a highly regulated and practically ripple free dc source.

### Specifications

Current : 0-20mA  
Resolution : 10 $\mu$ A  
Accuracy :  $\pm 0.2\%$  of the reading  $\pm 1$  digit  
Load regulated : 0.03% for 0 to full load  
Line regulation : 0.05% for 10% variation

The details of other sub-units can be had from their respective data-sheets.

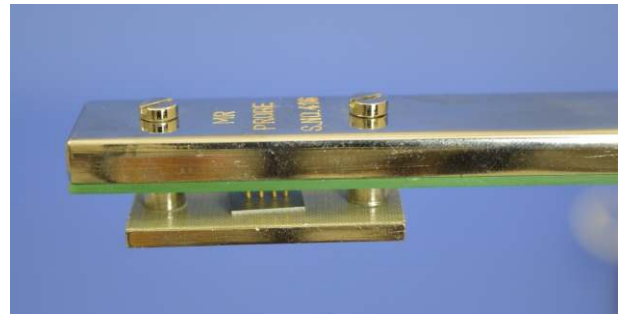

# Magnetoresistance Setup (Research Model)

MRX-RMN

SES Instruments Pvt Ltd.

## MEASUREMENT OF MAGNETORESISTANCE OF WIDE VARIETY OF SAMPLES



### Description

It is noticed that the resistance of the sample changes when the magnetic field is turned on. The phenomenon, called magnetoresistance, is due to the fact that the drift velocity of all carriers is not same. With the magnetic field on; the Hall voltage  $V = E_y t = |\mathbf{v} \times \mathbf{H}|$  compensates exactly the Lorentz force for carriers with the average velocity; slower carriers will be over compensated and faster one under compensated, resulting in trajectories that are not along the applied field. This results in an effective decrease of the mean free path and hence an increase in resistivity.

Here the above referred symbols are defines as:

$\mathbf{v}$  = drift velocity

$\mathbf{E}$  = applied electric field

$t$  = thickness of the crystal

$\mathbf{H}$  = magnetic field

## Description of Experimental Set-up

### 1. Probes Arrangement

It consists of 4 collinear, equally spaced (2mm) and individually spring loaded probes mounted on a PCB strip. Two outer probes for supplying the constant current to the sample and two inner probes for measuring the voltage developed across these probes. This eliminates the error due to contact resistance which is particularly serious in semiconductors. A platform is also provided for placing the sample and mounting the Four Probes on it.

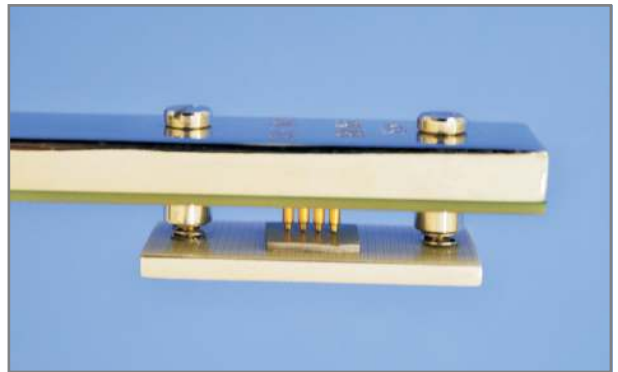

### 2. Control Unit of Four Probe Setup

The unit comprises of two sections – a totally isolated constant current source, and a grounded voltage measurement system. Features of these two sections are described below in some detail.

#### (A) Constant Current Source

It is an IC regulated current generator that is galvanically isolated from the rest of the circuit which is a basic requirement of four probe method. The isolation is achieved by using an optically coupled amplifier and associated circuits. This circuit sends a constant Current. To the changing resistance of the sample due to change in temp..



A judicious choice of the current setting as detailed in the user manual is necessary depending on the resistance value that is measured. Brief technical details of the current section are as under:

- Current Range: 2 $\mu$ A, 20 $\mu$ A, 200 $\mu$ A, 2mA, 20mA and 200mA with over ranging
- Open Circuit Voltage: 30V
- Accuracy :  $\pm 0.25\%$  of the reading  $\pm 1$  digit
- 4-line LCD display with indication when current needs decreasing

### (b) Digital Voltmeter Section

The voltmeter is used to read the voltage developed between the middle pins of the four probe arrangement. A primary requirement is to have very high input resistance so that the measurement is not disturbed in case of high resistance samples. The input range of the voltmeter is thus limited by avoiding the use of any potential divider. Brief technical details are as under:

- Voltage Range: 2mV, 20 mV, 200 mV, 2V with over ranging
- Manual adjustment of Offset Voltage whenever current/voltage range is changed
- Accuracy :  $\pm 0.25\%$  of the reading  $\pm 1$  digit
- 4-line LCD display with over voltage indication

### 3. Standard Sample

Ge Crystal (n-type) dimensions: 10 x 10 x 0.5mm.

*(This standard sample is included to enable the user to check the functioning of the setup)*

4. Electromagnet, EMU-75T (Refer datasheet for specifications)

5. Constant Current Power Supply, DPS-175-C2 (Refer datasheet for specifications)

6. Digital Gaussmeter, DGM-202-C1 (Refer datasheet for specifications)

*In addition to the above, this Magnetoresistance Setup may be connected to a computer for data logging purposes. Necessary hardware and software are optional and can be purchased separately .*

***The setup is complete in itself***

# Magnetoresistance Setup (Research Model)

MRX-RMC

SES Instruments Pvt Ltd.

## MEASUREMENT OF MAGNETORESISTANCE OF WIDE VARIETY OF SAMPLES



### Description

It is noticed that the resistance of the sample changes when the magnetic field is turned on. The phenomenon, called magnetoresistance, is due to the fact that the drift velocity of all carriers is not same. With the magnetic field on; the Hall voltage  $V = E_y t = |\mathbf{v} \times \mathbf{H}|$  compensates exactly the Lorentz force for carriers with the average velocity; slower carriers will be over compensated and faster one under compensated, resulting in trajectories that are not along the applied field. This results in an effective decrease of the mean free path and hence an increase in resistivity.

Here the above referred symbols are defines as:

$\mathbf{v}$  = drift velocity

$\mathbf{E}$  = applied electric field

$t$  = thickness of the crystal

$\mathbf{H}$  = magnetic field

## Description of Experimental Set-up

### 1. Probes Arrangement

It consists of 4 collinear, equally spaced (2mm) and individually spring loaded probes mounted on a PCB strip. Two outer probes for supplying the constant current to the sample and two inner probes for measuring the voltage developed across these probes. This eliminates the error due to contact resistance which is particularly serious in semiconductors. A platform is also provided for placing the sample and mounting the Four Probes on it.

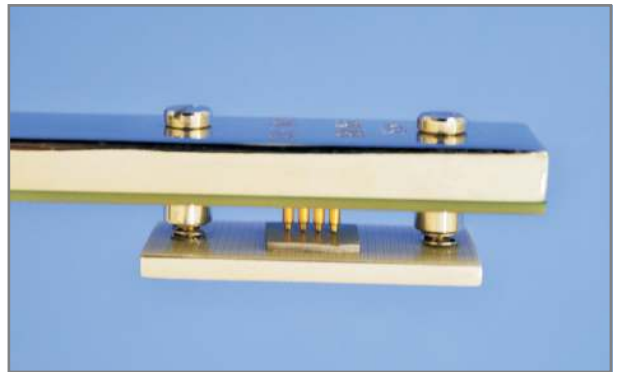

### 2. Control Unit of Four Probe Setup

The unit comprises of two sections – a totally isolated constant current source, and a grounded voltage measurement system. Features of these two sections are described below in some detail.

#### (A) Constant Current Source

It is an IC regulated current generator that is galvanically isolated from the rest of the circuit which is a basic requirement of four probe method. The isolation is achieved by using an optically coupled amplifier and associated circuits. This circuit sends a constant Current. To the changing resistance of the sample due to change in temp..



A judicious choice of the current setting as detailed in the user manual is necessary depending on the resistance value that is measured. Brief technical details of the current section are as under:

- Current Range: 2 $\mu$ A, 20 $\mu$ A, 200 $\mu$ A, 2mA, 20mA and 200mA with over ranging
- Open Circuit Voltage: 30V
- Accuracy :  $\pm 0.25\%$  of the reading  $\pm 1$  digit
- 4-line LCD display with indication when current needs decreasing

### (b) Digital Voltmeter Section

The voltmeter is used to read the voltage developed between the middle pins of the four probe arrangement. A primary requirement is to have very high input resistance so that the measurement is not disturbed in case of high resistance samples. The input range of the voltmeter is thus limited by avoiding the use of any potential divider. Brief technical details are as under:

- Voltage Range: 2mV, 20 mV, 200 mV, 2V with over ranging
- Manual adjustment of Offset Voltage whenever current/voltage range is changed
- Accuracy :  $\pm 0.25\%$  of the reading  $\pm 1$  digit
- 4-line LCD display with over voltage indication

### 3. Standard Sample

Ge Crystal (n-type) dimensions: 10 x 10 x 0.5mm.

*(This standard sample is included to enable the user to check the functioning of the setup)*

### 4. Electromagnet, EMU-75T (Refer datasheet for specifications)

### 5. Constant Current Power Supply, DPS-175-C2 (Refer datasheet for specifications)

### 6. Digital Gaussmeter, DGM-202-C1 (Refer datasheet for specifications)

### 7. SES-CAMM

This is SES computer aided measurement module, which act as an interface between computer and different subunits of this experiment.

***In addition to the above, this Magnetoresistance Setup may be connected to a computer for data logging purposes. Necessary hardware and software are included in the system.***

***The setup is complete in itself***



# Two Probe Setup

TPX-200N

SES Instruments Pvt. Ltd.

**Two Probe Method for resistivity measurement of near insulators at different temperatures**

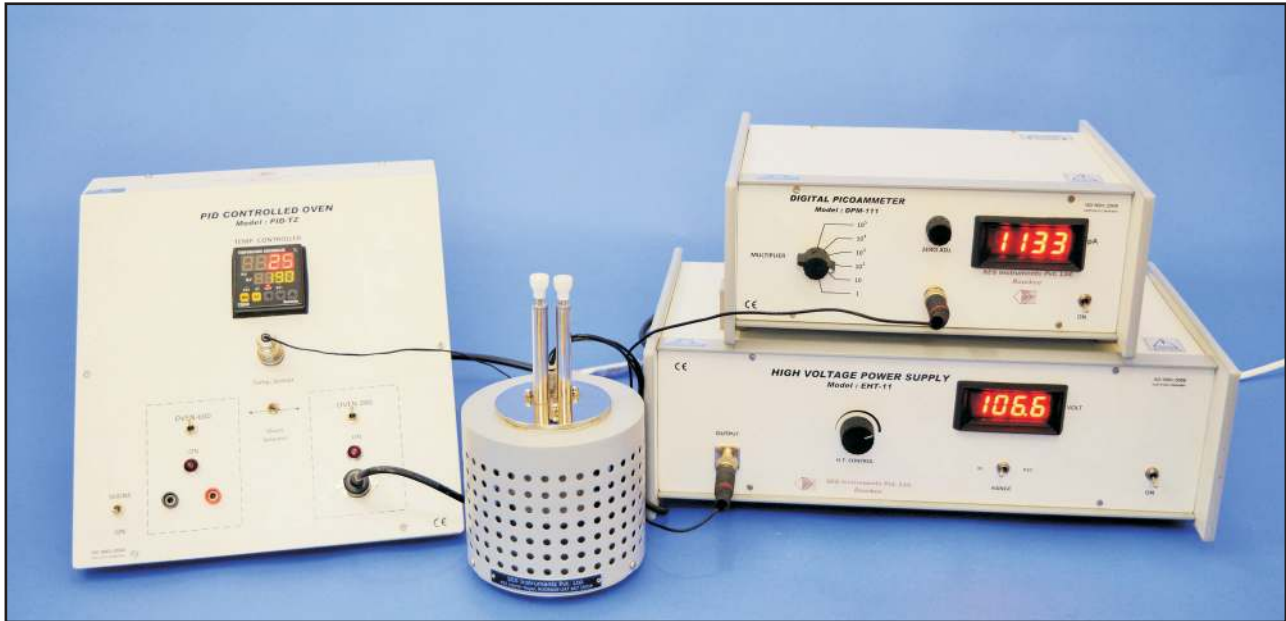

## Description

The Two Probe Method is one of the standard and most commonly used method for the measurement of resistivity of very high resistivity samples like sheets/films of polymers. The resistivity measurement of such samples is beyond the range of Four Probe Method.

## Description of Experimental Set-up

### 1. Two Probe Arrangement

It has two spring load contact probes. These probes move in a pipe and are insulated by Teflon washers. This probes arrangement is mounted in a suitable stand, which also holds the sample plate and RTD sensor. The stand also serves as the lid of PID Controlled Oven. Teflon coated leads are provided for connecting with High Voltage Power Supply EHT-11 and Digital

## 2. PID Controlled Oven, PID-TZN

The unit is a high quality PID controller wherein the temperatures can be set and controlled easily. The P, I and D parameters are factory set for immediate use however the user may adjust these for specific applications as well as autotune the oven whenever required. The steps for these are given in the user manual. Although the controller may be used either for our small oven, up to 200°C or a larger oven up to 600°C, however, in the present setup only small oven is to be used. The controller uses thermocouple as temperature sensor.



### Specifications of the Temperature Controller

The controller is designed around Autonics Temperature Controller Model TZN4S. Although this is a very versatile piece of equipment, below is a summary of the specifications that are relevant to the present application. The PID parameters are factory set to a reasonable level (P = 1.8; I = 300; D = 80) for immediate operation of the unit.

- Temperature Range: Ambient to 200°C
- Oven: Specially designed for Four Probe Set-Up
- Display Accuracy:  $\pm 0.3^{\circ}\text{C}$
- Sensor: Thermocouple (Chromel-Alumel)
- Setting Type: Front push buttons
- Display: 7 segment LED, two rows
- Control Method: PID, PIDF, PIDS
- Values: Process Value, PV and Set Value, SV
- Temperature control range: Ambient to 200°C
- Power: 150W



## 3. High Voltage Power Supply, EHT-111-C1

Specifications as per datasheet attached

## 4. Digital Picoammeter, DPM-111-C2

Specifications as per datasheet attached

**The setup is complete in itself**

### Optional Attachments

Two Probe Setup may be connected to a computer



# TPX-200C

## Two Probe Setup

**Two Probe Method for resistivity measurement of near insulators at different temperatures (ambient to 200°C) with computer interfacing facility**

### Introduction

The Two Probe Method is one of the standard and most commonly used method for the measurement of resistivity of very high resistivity samples near insulators. The resistivity measurement of such samples is beyond the range of Four Probe Method.



### Description of the Experimental Set-up

#### 1. Two Probes Arrangement, TPA-01

It has two spring load contact probes. These probes move in a pipe and are insulated by teflon washers. This probes arrangement is mounted in a suitable stand, which also holds the sample plate and RTD sensor. The stand also serves as the lid of PID Controlled Oven. Teflon coated leads are provided for connecting with High Voltage Power Supply EHT-11-C1 and Digital Picoammeter DPM-111-C2. With this set-up assuming maximum voltage 1500V; minimum current  $10^{-12}$  A and thickness of sample 1mm, the resistivity of the sample could be measured upto  $10^{14}$  ohm.cm..

#### 2. PID Controlled Oven (PID-TZ-C1)

Specifications as per datasheet attached.

#### 3. DPM-111-C2

Specifications as per datasheet attached.

#### 4. EHT-11-C1

Specifications as per datasheet attached.

#### 5. Computer Interface, SES-CAMM

This interface (SES-CAMM) provides, option to user, to interface the setup with the computer for acquiring data (temperature, current and voltage) and plotting it in real time. The data can also be stored in an excel file which can be used for further analysis. The software is menu driven and can be operated very easily.

The set-up is complete in all respect, except the computer.

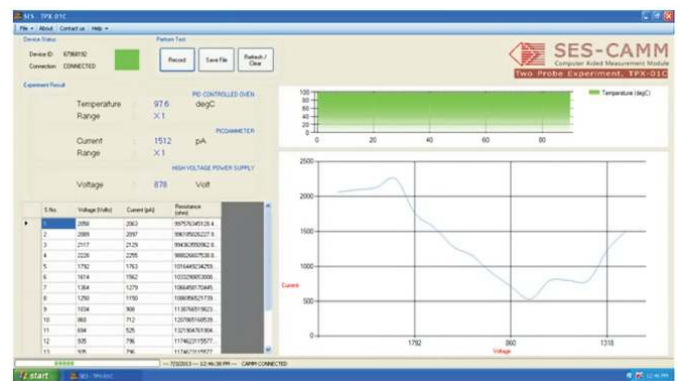

# Two Probe Setup

TPX-600N

SES Instruments Pvt. Ltd.

Two Probe Method for resistivity measurement of near insulators at different temperatures



## Description

The Two Probe Method is one of the standard and most commonly used method for the measurement of resistivity of very high resistivity samples like sheets/films of polymers. The resistivity measurement of such samples is beyond the range of Four Probe Method.

## Description of Experimental Set-up

### 1. Two Probe Arrangement

It has two spring load contact probes. These probes move in a pipe and are insulated by Teflon washers. This probes arrangement is mounted in a suitable stand, which also holds the sample plate and RTD sensor. The stand also serves as the lid of PID Controlled Oven. Teflon coated leads are provided for connecting with High Voltage Power Supply EHT-11 and Digital Picoammeter DPM-111. With this set-up assuming max.

-12

## 2. PID Controlled Oven, PID-TZN

The unit is a high quality PID controller wherein the temperatures can be set and controlled easily. The P, I and D parameters are factory set for immediate use however the user may adjust these for specific applications as well as autotune the oven whenever required. The steps for these are given in the user manual. Although the controller may be used either for our small oven, up to 200°C or a larger oven up to 600°C, however, in the present setup only large oven is to be used. The controller uses thermocouple as temperature sensor.



### Specifications of the Temperature Controller

The controller is designed around Autonics Temperature Controller Model TZN4S. Although this is a very versatile piece of equipment, below is a summary of the specifications that are relevant to the present application. The PID parameters are factory set to a reasonable level (P = 1.8; I = 300; D = 80) for immediate operation of the unit.

- Temperature Range: Ambient to 600°C
- Oven: Specially designed for Four Probe Set-Up
- Display Accuracy:  $\pm 0.3^{\circ}\text{C}$
- Sensor: Thermocouple (Chromel-Alumel)
- Setting Type: Front push buttons
- Display: 7 segment LED, two rows
- Control Method: PID, PIDF, PIDS
- Values: Process Value, PV and Set Value, SV
- Temperature control range: Ambient to 600°C
- Power: 150W



## 3. High Voltage Power Supply, EHT-111-C1

Specifications as per datasheet attached



## 4. Digital Picoammeter, DPM-111-C2

Specifications as per datasheet attached

**The setup is complete in itself**



### Optional Attachments

This Two Probe Setup may be connected to a

# TPX-600C

## Two Probe Setup

Two Probe Method For Resistivity Measurement of Near Insulators at Different Temperatures (Ambient to 600°C) with computer interfacing facility



### Description

Behaviour of resistivity of substrate such as polymer sheets/ films at higher temperatures is an important area of investigation due to their variety of applications. Two Probe Method is one of the standard and most commonly used method for the measurement of resistivity of very high resistivity samples like sheets/films of polymers. The resistivity measurement of such samples is beyond the range of Four Probe Method.

### Description of the experimental set-up

#### 1. Two Probes Arrangement

It has two individually spring loaded probes. The probes arrangement is mounted in a suitable stand of high quality alumina which also holds the sample plate. To ensure the correct measurement of sample temperature, the thermocouple junction is embedded in the sample plate just below the sample. This stand also serves as the lid of temperature controlled oven. Proper leads are provided for connection to Capacitance Meter and Temperature Controller.

#### 2. High Temperature Oven

This is a high quality temperature controlled oven. The heating element used is a high grade Kanthal-D. It is mounted on a custom made grooved, sintered alumina fixture to avoid any slippage of heating wire.

Heat shield is also provided to reduce the excessive heating of outer cover. Further the top portion is also suitably covered to meet the safety standard. The oven has been designed for fast heating and cooling rates, which enhances the effectiveness of the controller.

#### 3. PID Temperature Controller



The unit is a high quality PID controller wherein the temperatures can be set and controlled easily. The P, I and D parameters are factory set for immediate use however the user may adjust these for specific applications as well as auto-tune the oven whenever required. The steps for these are given in the user manual. Although the controller may be used either for our small oven, up to 200°C or a larger oven up to 600°C, however, in the present setup only large oven is to be used. The controller

# TPX-600C

## Two Probe Setup

### Specifications

Temperature Range	: Ambient to 600°C
Power Supply	: 100-240VAC; 50/60Hz
Display	: Method 7 Segment LED display [Processing value (PV):Red, Setting value (SV):Green]
Input Sensor	: Thermocouple (Chromel - Alumel)
Control Method	: PID, ON/OFF Control, P, PI, PD, PIDF, PIDS
Display Accuracy	: ± 0.3%
Setting Type	: Setting by front push buttons
Proportional Band (P)	: 0 to 100.0%
Integral Time (I)	: 0 to 3600 Sec
Derivative Time (D)	: 0 to 3600 Sec
Control Time (T)	: 1 to 120 Sec
Sampling Time	: 0.5 Sec
Setting (P, I & D)	: Manual / Auto
Interfacing	: USB connection through SES- CAMM

#### 4. High Voltage Power Supply, Model EHT-11C



Specifications as per datasheet attached

#### 5. Digital Picoammeter, Model DPM-111C



Specifications as per datasheet attached

#### 6. Computer Interface, SES-CAMM



An interface (SES-CAMM) provides the option to the user to interface it with the computer for acquiring and storing the data (temperature, current and voltage) and plotting in real time. The data is also stored in an excel file which can be used for further analysis. The software is menu driven and can be operated very easily.

Interfacing : PC connectivity through USB.  
Individual unit connectivity through BNC connector

Software : Fully integrated software capable of display and storing data in different configuration . Compatible with Window XP/7/8.



The experimental set-up is complete in all respect

# ESR-105

## Electron Spin Resonance Spectrometer

### Features

- FET based marginal R.F. Oscillator
- Digital display of frequency
- Excellent peaks display
- Digital display of Helmholtz Coil Current
- Compatible with general purpose CRO in X-Y mode

### Introduction

In recent years Magnetic Resonance has developed into a very useful and powerful tool in solid state research. In this method, use is made of the Zeeman interaction of the magnetic dipoles associated with the nucleus or electron, when placed in an external magnetic field. Accordingly, they are identified as NMR (Nuclear Magnetic Resonance) or ESR (Electron Spin Resonance). This form of spectroscopy finds many applications in the investigation of crystal structures, environmental effects, dynamic effects, defects in solids and in many diverse branches of Physics, Chemistry and Biology.

### Elementary Magnetic Resonance

We know that the intrinsic angular momentum (spin) of the electron  $\bar{S}$  couples with the orbital angular momentum of the electron  $\bar{L}$  to give a resultant  $\bar{J}$  and this coupling gives rise to the 'fine structure' of the spectra. Further, under the influence of an external magnetic field (H) each of the level will split into  $(2j+1)$  sub levels (Zeeman effect) and the splitting of a level will be

$$\Delta E = (g\mu_0 H)m_j$$

where  $\mu_0$  is the Bohr magneton,  $g$  is the Lande' g-factor and  $m_j$  is the magnetic quantum number. As can be seen, the splitting is not same for all levels; it depends on the  $J$  and  $L$  of the level ( $s=1/2$  always for one electron). However, the sub levels will split equally by an amount

$$\Delta E = g\mu_0 H \quad \text{or} \quad h\nu_0$$

where  $\nu_0$  is the frequency of the

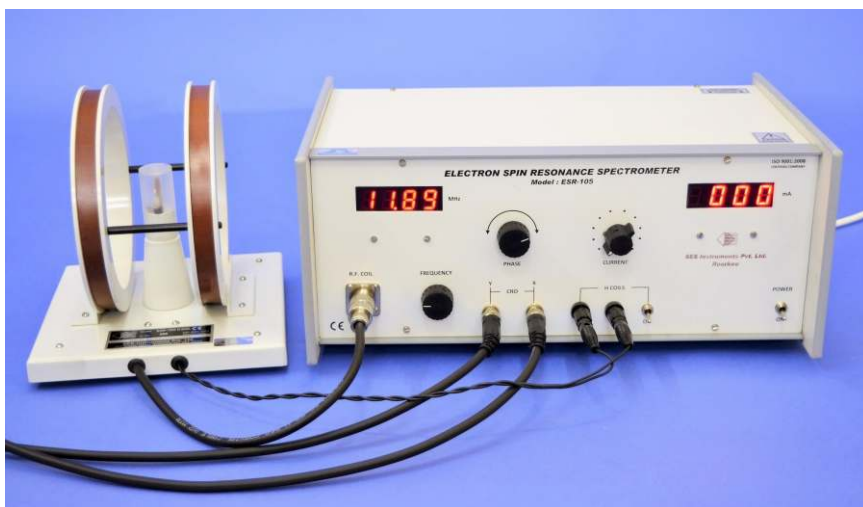

system. Now if the electron is subjected to a perturbation by an oscillating magnetic field with its direction perpendicular to the static magnetic field and its frequency  $\nu_1$  such that the quantum  $h\nu_1$  is equal to  $E=h\nu_0$ , we say that there is a resonance between  $\nu_1$  and  $\nu_0$ . This will induce transition between neighbouring sublevels ( $m_j = \pm 1$ ) and in turn will absorb energy from oscillating field. Thus, at resonance, we get a peak due to the absorption of energy by the system.

### Experimental Technique

If we consider a free electron and substitute the proper value of constants in the equation:  $g = 2.00$ ,  $\mu_0 = 0.927 \times 10^{-20}$  erg/gauss and  $h = 6.625 \times 10^{-27}$  erg sec, we get

$$\frac{\nu_0}{H_0} = 2.8 \text{ MHz/gauss}$$

That is ESR can be observed at radio frequencies in a magnetic field of a few gauss or in the microwave region in a magnetic field of a few kilogauss. The latter alternate has many advantages: improved signal-to-noise ratio, high resolution etc. and is always preferred for accurate work, though it is very sophisticated and expensive. However, if the basic understanding of the subject is the main criteria as is usually the requirement of class room experiments, the observation of ESR in low magnetic field and in a radio frequency region makes it a lot simple, inexpensive and within the reach of every post-graduate laboratory.

### Description of the ESR Spectrometer

A block diagram of the ESR Spectrometer is given below in Fig. 1, and a brief description follows.

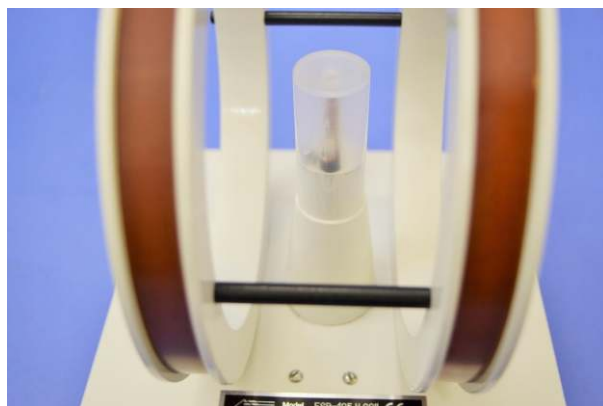

### Basic Circuit

The first stage of the ESR circuit consists of a critically adjusted (marginal) radio frequency oscillator with 4-digit frequency display. This type of oscillator is required here, so that the slightest increase in its load decreases the amplitude of oscillation to an appreciable extent. The sample is kept inside the tank coil of the oscillator, which in turn, is placed in the 50Hz magnetic field, generated by the Helmholtz coils. At resonance, i.e. when the frequency of oscillation equal to the Larmor's frequency of the sample, the oscillator amplitude registers a dip due to the absorption of power by the sample. This obviously, occurs periodically four times in each complete cycle of the supply voltage. The result is an amplitude modulated carrier which is then detected using a FET demodulator and amplified by an op-amp circuit.

Highly stabilised and almost ripple free power supply for the above circuit is obtained using an integrated circuit regulator.

### Phase Shifter

This can compensate the undermined phase difference which may be introduced in the amplification stages of the spectrometer and oscilloscope.

### 50Hz Sweep Unit

A 50Hz current flows through Helmholtz coils which provides a low frequency magnetic field to the sample. As the resonance is observed at few gauss only, no static magnetic field is applied.

### Oscilloscope (not supplied with the Spectrometer)

Any inexpensive oscilloscope normally available in the laboratory would be quite suitable.

### Advantages and Limitations of our Spectrometer

1. The instrument is basically designed for postgraduate laboratories keeping in view their requirements and limitations.
2. The observation of ESR at low magnetic fields and consequently in

radio-frequency region makes its instrumentation and working a lot simple and within the reach of a postgraduate students. Good resonance peaks can be obtained as a class room exercise.

3. The spectrometer is complete in all respects including a sample DPPH (except a CRO).

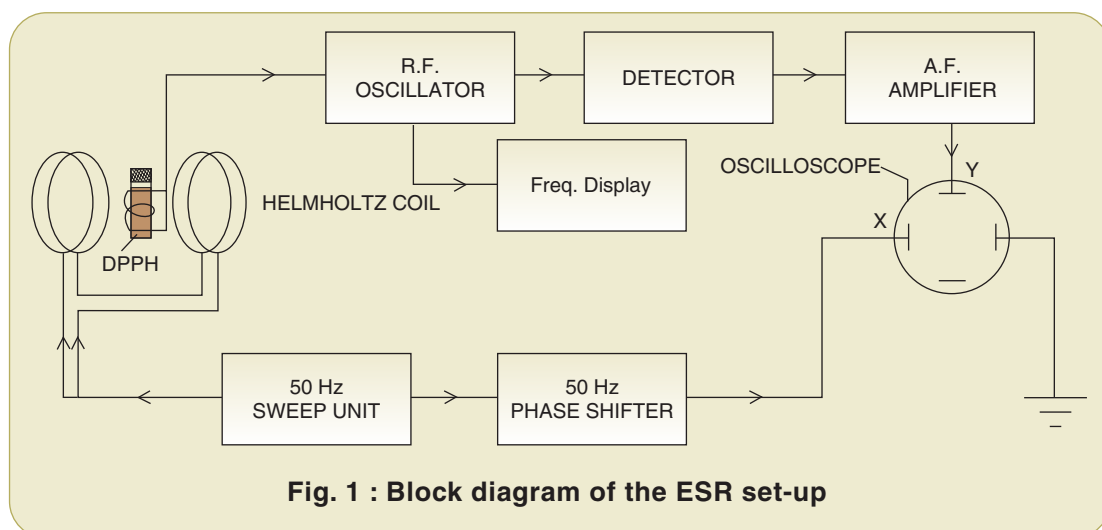
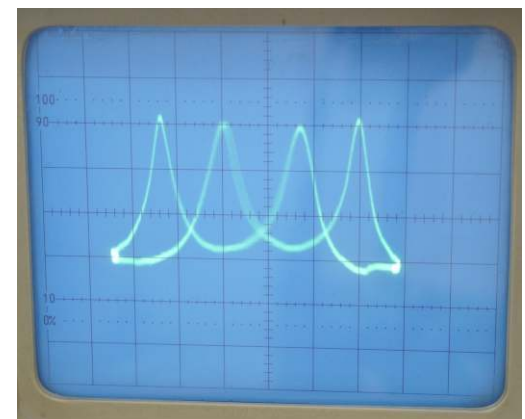
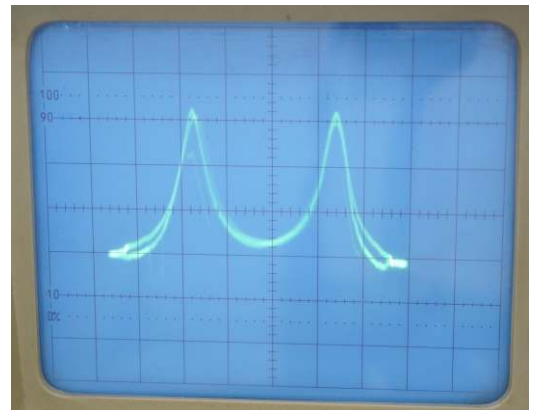

Fig. 1 : Block diagram of the ESR set-up

# NMR-01

## NMR Experiment

### Features

- Suitable for  $^1\text{H}$  and  $^{19}\text{F}$  nuclei
- FET based marginal Oscillator
- Digital Display of frequency and current
- Clear display of resonance peaks
- Compatible with general purpose CRO



### Introduction

Nuclear Magnetic Resonance (NMR) was discovered by Bloch and Purcell in the year 1945. Over the years it has developed into a very useful and powerful tool in solid state physics, chemistry and biology. In medical application this technique, under the name Magnetic Resonance Imaging (MRI) has been developed as an excellent imaging method for clinical diagnosis. In this method use is made of Zeeman interaction of the magnetic dipoles associated with the nucleus when placed in an external magnetic field.

### Elementary Magnetic Resonance

An atom whose nucleus has a nuclear spin  $I$  will have a magnetic moment  $\mu$  as follows:

$$\mu = g\mu_n I \quad (1)$$

where  $\mu_n$  is nuclear magneton, and  $g$  is  $g$  factor. Under the influence of an external static magnetic field ( $H$ ), these nuclear magnets can orient in distinct directions. Each spin orientation corresponds to a particular energy level given by:

$$E = g\mu_n H m_j \quad (2)$$

with  $m_j = -I, -(I-1), \dots, (I-1), I$  where  $m_j$  is magnetic quantum number

The splitting of levels will therefore be:-

$$\Delta E = g\mu_n H \quad \text{or} \quad = h\nu_0 \quad (3)$$

where  $\nu_0$  is the r. f. frequency applied perpendicular to the static magnetic field. Now if the spins are subjected to a perturbation by an oscillating magnetic field with its direction parallel to the static magnetic field and its frequency  $\nu_1$  such that the quantum  $h\nu_1$  is equal to  $\Delta E = h\nu_0$ , we say that there is a resonance between  $\nu_1$  and  $\nu_0$ .

This will induce transition between neighbouring sub levels ( $m_j = I$ ) and in turn will absorb energy from the oscillating field. Thus, at resonance, we get a peak due to the absorption of energy by the system.

### Experimental Technique

In our experiment the NMR signals of Hydrogen nuclei and Fluorine nuclei are detected. Both have only two possible orientations in reference to static magnetic field  $H$  since both have proton spin  $I = 1/2$ . The sample is placed in an r.f. coil located between the gap of homogeneous magnetic field  $H$ . In order to exactly match equation (3),  $H$  is modulated at constant frequency (50Hz in our case) by using two modulation coils. Each time when the matching (resonance) condition (Eq. 3) is fulfilled, energy is absorbed from the r.f. coil due to the spin transition.



Proton Resonance

### Description of the NMR Spectrometer

The block diagram of the NMR spectrometer is given below in Fig.1 and a brief description follow:-.

#### Basic Circuit

The first stage of the NMR circuit consists of a critically adjusted (marginal) radio frequency oscillator with 4-digit frequency display. This type of oscillator is required here, so that the slightest increase in its load decreases the amplitude of oscillation to an appreciable extent. The sample is kept inside the tank coil of the oscillator, which in turn, is placed in the 50Hz magnetic field, generated by the Helmholtz coils and a permanent magnet. At resonance, i.e. when the frequency of oscillation equal to the Larmour's frequency of the sample, the oscillator amplitude registers a dip due to the absorption of power by the sample. This obviously, occurs periodically two times in each complete cycle of the modulating magnetic field. The result is an amplitude modulated carrier which is then detected using a FET demodulator and amplified by an op-amp circuit.

#### Permanent Magnet

Two high field permanent magnets have been used in H structure and adjusted to produce highly uniform high magnetic field.

#### 50Hz Sweep Unit

A 50Hz current flows through Helmholtz coils which provides a low frequency magnetic field to the sample.

#### Oscilloscope (not supplied with the Spectrometer).

Any dual trace oscilloscope normally available in the laboratory would be quite suitable.

### Advantages and Limitations of our Spectrometer

1. The instrument is basically designed for postgraduate laboratories keeping in view their requirements and limitations.
2. The observation of NMR at low perturbing magnetic fields with high ~5KG static field and consequently in radio-frequency region makes its instrumentation and working a lot simple and within the reach of postgraduate students. Good resonance peaks can be obtained as a class room exercise.
3. The spectrometer is complete in all respects except a CRO.

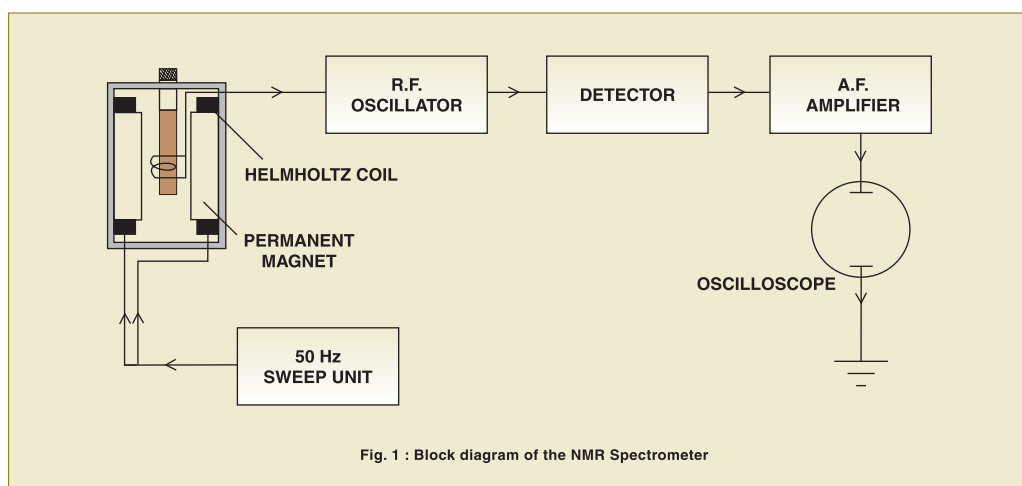
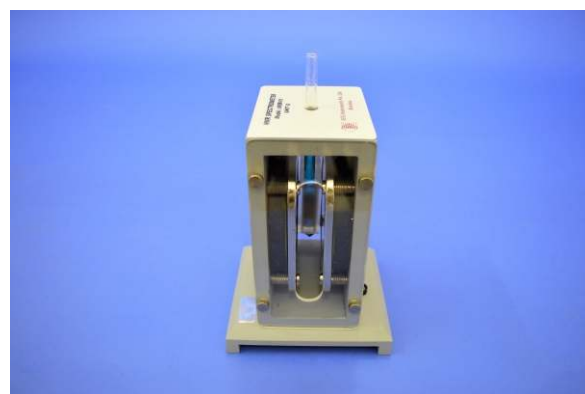

The trace shows the resonance when proton precession matches the oscillator frequency

# TLX-02

## Study of Thermoluminescence of F-Centres

### Study of Thermoluminescence of F-centers in Alkali Halide Crystals



Pure alkali halide crystals are transparent throughout the visible region of the spectrum. The crystals may be colored in a number of ways

- (1) by the introduction of chemical impurities
- (2) by introducing an excess of the metal ion
- (3) by X-ray,  $\gamma$ -ray, neutron and electron bombardment
- (4) by electrolysis

A colour centre is a lattice defect that absorbs visible light. The simplest colour center is an F-centre. The name comes from the German word for colour, Forbs. We usually produce F-centres by heating the crystal in excess alkali vapours or by irradiation. The new crystals show an absorption band in the visible or ultraviolet, whereas the original crystals are transparent in that region. This absorption band is called F-band.

An F-centre can be regarded as a negative ion vacancy and an electron which is equally shared by the positive ions, surrounding the vacant lattice site. Conversely a hole may be trapped at a +ve ion vacancy or at a -ve ion, giving rise to V- and H-centres respectively.

#### Colour centres produced by irradiation with X-rays

When a X-ray quantum passes through an ionic crystal, it will usually give rise to a fast photo-electron with an energy of the same order as that of the incident quantum. Such electrons, because of their small mass, do not have sufficient momentum to displace ions and therefore lose their energy in producing free electrons, holes, excitons and phonons. Evidently these while moving near the vacancies form trapped electrons as well as trapped holes.

The trapped-electron or trapped-hole centres so formed can be destroyed (bleached) by illuminating the crystal with light of the appropriate wavelength or warming it.

#### Thermoluminescence

Important information about the colour centres can be obtained by measuring the changes that occur when a coloured crystal is gradually heated. As the temperature is raised electrons and holes escape from their traps at an increasing rate. The freed charges can recombine with each other or with other defects and give out luminescence by recombination. The resulting thermoluminescence or 'glow' reaches maximum and then decreases to zero as the supply of trapped electrons or holes becomes exhausted. The plot of luminescence intensity versus temperature, taken at a constant heating rate, is called the 'glow curve'. It may contain one or many glow peaks, depending upon whether there are one or several different kinds of traps.

From the glow curve one determine the trap depth; the deeper the trap, the higher the temperature of the glow peak.

A correlation between the temperature at which thermoluminescence occurs and the temperature at which particular band bleach can give valuable information about specific centres.

Typical results obtained from this set-up for KCl crystal are shown in figure.

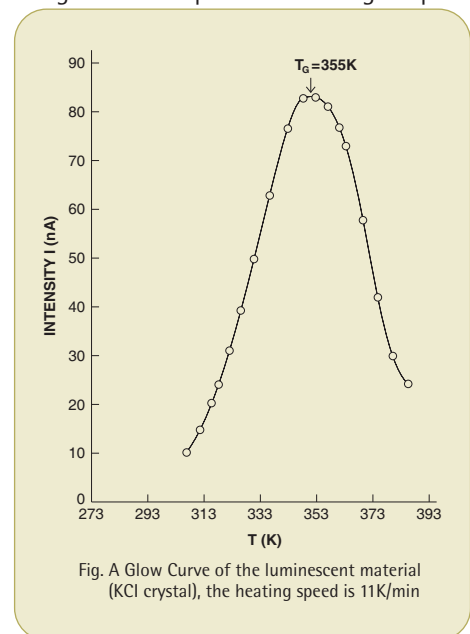

Fig. A Glow Curve of the luminescent material (KCl crystal), the heating speed is 11K/min

### The experiment consists of the following

Experimental set-up for creating thermoluminescence

- (1) Sample: KBr or KCl single crystal
- (2) Thermoluminescence Temperature Meter, TL-02
  - Digital Thermometer
  - Oven Power Supply
- (3) Sample Holder
- (4) Thermoluminescence Oven (0-423K)
- (5) Black Box

### For measurement of luminescence intensity

- (1) Photomultiplier tube: R11558
- (2) PMT Housing with biasing circuit and coaxial cables etc.
- (3) High Voltage Power Supply, Model: EHT-11
  - Output : 0-1500V variable (1mA max.)
  - Regulation : 0.05%
  - Display : 3½ digit 7-segment LED
- (4) Nanoammeter, Model DNM-121
  - Range : 100nA to 100mA full scale in 4 ranges
  - Accuracy : 0.2%.
  - Display : 3½ digit 7-segment LED

### Photomultiplier Tube

Specifications of Photomultiplier tube R11558

Spectral Response

- Range : 300 to 650(nm)
- Peak wave length : 400nm

Photo Cathode Material : Bialkali

Dynode Structure/No. of Stages : CC/9

Maximum Cathode Voltage : 1250Vdc

Maximum Average Anode Current : 0.1mA

Cathode Sensitivity

- Minimum : 40µA/lm
- Typical : 60µA/lm

Anode Sensitivity

- Minimum : 200A/lm
- Typical : 600A/lm

Anode to Cathode Supply Voltage : 1000Vdc

Current Amplification :  $1.0 \times 10^7$

Anode Dark Current (after 30min)

- Typical : 1nA
- Maximum : 10nA

### PMT Housing

The housing is designed to provide a shielding from stray light and

magnetic field. The slit arrangement at the window is provide to adjust the size of the window according to the incident beam and for the safety of photomultiplier tube when not in use. For E.H.T. input and current output, amphenol connectors are provided. A general purpose biasing circuit, using low noise, metal film resistors, is mounted on the base. The housing can be mounted in any position.

The biasing circuit can be changed to customer's specification. Minor modification in design of PMT Housing is also possible.

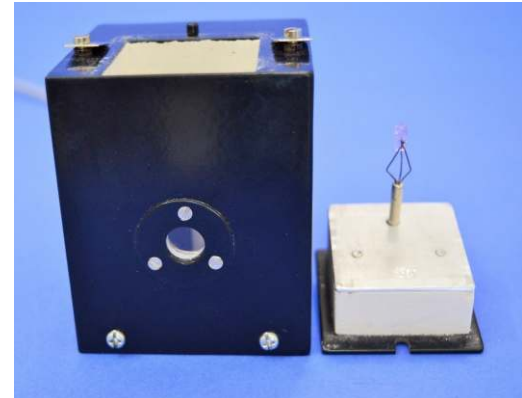

Thermoluminescence Irradiation unit TIU-02 can also be used for this purpose.

**complete in all respect, only X-ray facilities required to create F-centers in the crystal.**

# TIU-02

## Thermoluminescence Irradiation Unit

Irradiation unit suitable for irradiating alkali halide samples for Thermoluminescence Experiment

- Microcontroller based menu driven
- Cost effective solution
- No radiation hazard
- High quality double stage rotary pump
- Long life tesla coil
- Fully self contained

### Introduction

Study of Thermoluminescence in alkali halide crystals need creation of F-centres (colour centres) in alkali halide crystals. To produce the F-centres, the crystals are exposed to ionizing radiation which in turn causes the loss of electron from halide ions. An electron then becomes trapped in the halide ion vacancy. The color is the result of the absorption of a photon by the trapped electron and excitation from the ground state to an excited state for the F-center. This is a classic case of particle in a box.

The source of ionizing radiation could be X-rays, electrons, gamma rays etc. These techniques are too Expensive and unaffordable for normal laboratories. Another method, although little less efficient, is by keeping Alkali halide crystals under low pressure, in the proximity of high Voltage. This in turn produces F-centres in the crystals.

This later technique has been adopted in this set up to make it economical and affordable for all laboratories. The setup is complete in itself and can be used straight away.



### Specifications

Vacuum	:	~15 micron
Extra High Voltage	:	~30,000VAC pulsating
Sample Size	:	Upto 6mmx6mmx1mm
Input Mains	:	220VAC, 50Hz

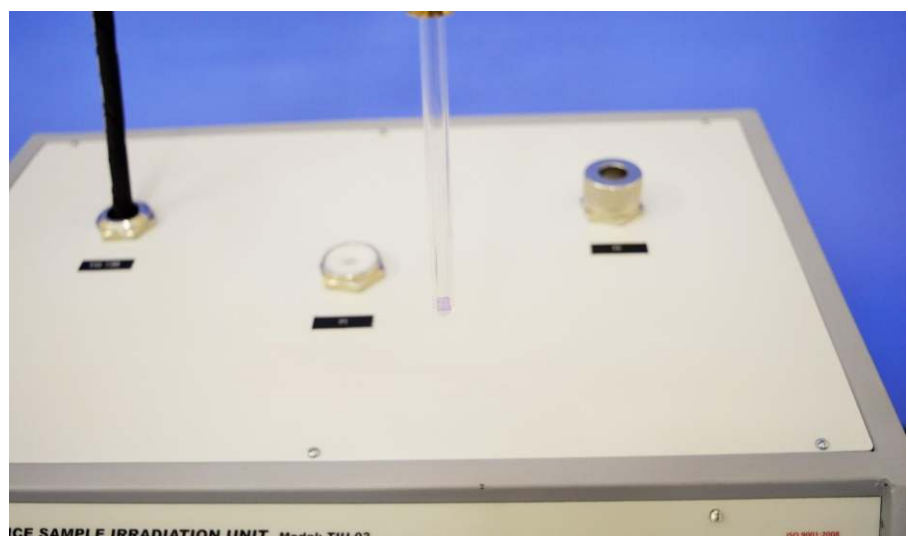

# HEX-21

## Hall Effect Experiment

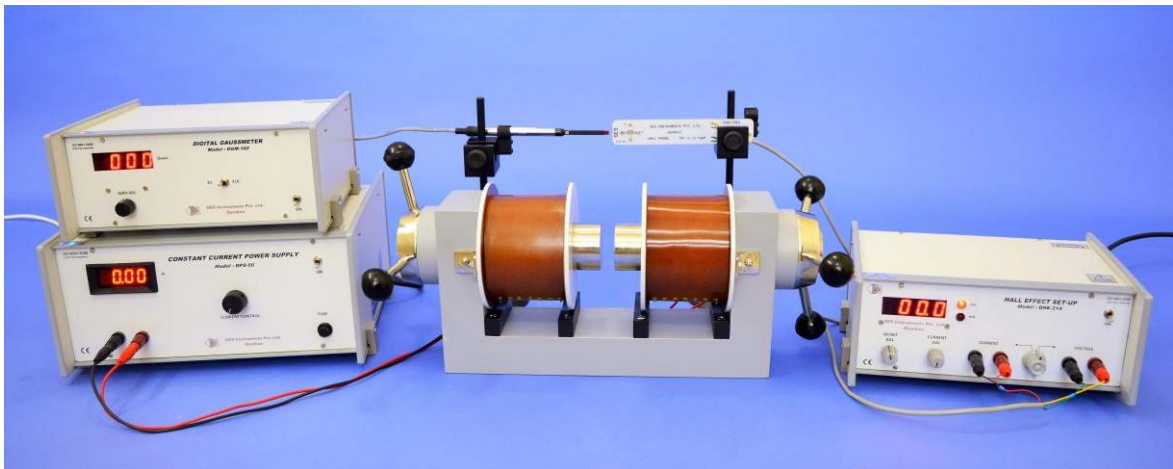

### Introduction

The resistivity measurements of semiconductors can not reveal whether one or two types of carriers are present; nor distinguish between them. However, this information can be obtained from Hall Coefficient measurements, which are also basic tools for the determination of carrier density and mobilities in conjunction with resistivity measurement.

### Theory

As you are undoubtedly aware, a static magnetic field has no effect on charges unless they are in motion. When the charges flow, a magnetic field directed perpendicular to the direction of flow produces a mutually perpendicular force on the charges. When this happens, electrons and holes will be separated by opposite forces. They will in turn produce an electric field ( $\vec{E}_h$ ) which depends on the cross product of the magnetic intensity,  $\vec{H}$ , and the current density,  $\vec{J}$ .

$$\vec{E}_h = R\vec{J} \times \vec{H}$$

Where  $R$  is called the Hall Coefficient

Now, let us consider a bar of semiconductor, having dimension,  $x$ ,  $y$  and  $z$ . Let  $\vec{J}$  is directed along  $X$  and  $\vec{H}$  along  $Z$  then  $\vec{E}_h$  will be along  $Y$ .

Then we could write

$$R = \frac{V_h/y}{JH} = \frac{V_h/z}{IH}$$

Where  $V_h$  is the Hall voltage appearing between the two surfaces perpendicular to  $y$  and  $I = Jyz$

**Hall Effect experiment consists of the following:**

1. Hall Probe (Ge Crystal) n & p-type
2. Hall Effect Set-up, DHE-21C
3. Electromagnet, EMU-50V
4. Constant Current Power Supply, DPS-50C
5. Digital Gaussmeter, DGM-202C

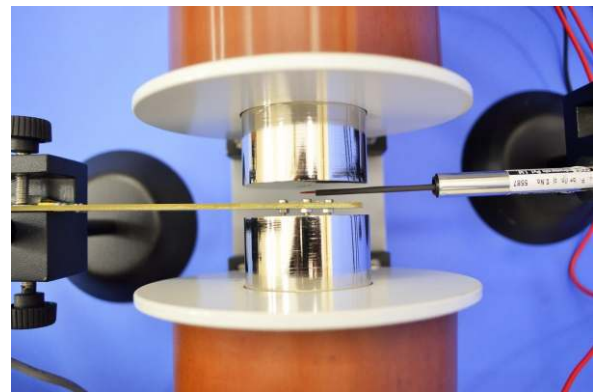

### Hall Probe (Ge Crystal)

Ge single crystal with four spring-type pressure contacts is mounted on a sunmica-decorated bakelite strip. Four leads are provided for connections with measuring devices.

### Technical details

Material	: Ge single crystal n or p-type as desired
Resistivity	: 8-10Ω.cm
Contacts	: Spring type (solid silver)
Zero-field potential	: <1mV (adjustable)
Hall Voltage	: 25-35mV/10mA/KG

It is designed to give a clear idea to the students about Hall Probe and is recommended for class room experiment. A minor drawback of this probe is that it may require zero adjustment.

### (b) Hall Probe (InAs)

Indium Arsenide crystal with 4 soldered contacts is mounted on a PCB strip and covered with a protective layer. The Hall Element is mounted in a pen-type case and a 4-core cable is provided for connections with the measuring device and current source.

# HEX-21

## Hall Effect Experiment



### Technical Details

Contacts	:	Soldered
Rated Control Current	:	4mA
Zero Field Potential	:	<4mV
Linearity (0-20KG)	:	±0.5% or better
Hall Voltage	:	60-70mV/4mA/KG

The crystal alongwith its four contacts is visible through the protective layer. This is mainly used as a transducer for the measurement of magnetic field.

### Hall Effect Set-up, DHE-21C



DHE-21C is a high performance instrument of outstanding flexibility. The set-up consists of a digital millivoltmeter and a constant current power supply. The Hall voltage and probe current can be read on the same digital panel meter through a selector switch. The unit is made compatible with SES-CAMM interface unit, for computer control option.

#### (i) Digital Millivoltmeter

Intersil 3½ digit single chip A/D Converter ICL 7107 have been used. It has high accuracy like, auto zero to less than 10µV, zero drift of less than 1µV/°C, input bias current of 10pA max. and roll over error of less than one count. Since the use of internal reference causes the degradation in performance due to internal heating, an external reference has been used. Digital voltmeter is much more convenient to use in Hall experiment, because the input voltage of



### Specifications

Range	:	0-200mV (100mV minimum)
Accuracy	:	±0.1% of reading ±1 digit

#### (ii) Constant Current Power Supply



This power supply, specially designed for Hall Probe, provides 100% protection against crystal burn-out due to excessive current. The supply is a highly regulated and practically ripple free dc source.

### Specifications

Current	:	0-20mA
Resolution	:	10µA
Accuracy	:	±0.2% of the reading ±1 digit
Load regulation	:	0.03% for 0 to full load
Line regulation	:	0.05% for 10% variation

Datasheets of other sub units is available separately. The experiment in complete in all respect.

# HEX-21C

## Hall Effect Experiment (with computer interface)



### Introduction

The resistivity measurements of semiconductors can not reveal whether one or two types of carriers are present; nor distinguish between them. However, this information can be obtained from Hall Coefficient measurements, which are also basic tools for the determination of carrier density and mobilities in conjunction with resistivity measurement.

### Theory

As you are undoubtedly aware, a static magnetic field has no effect on charges unless they are in motion. When the charges flow, a magnetic field directed perpendicular to the direction of flow produces a mutually perpendicular force on the charges. When this happens, electrons and holes will be separated by opposite forces. They will in turn produce an electric field ( $\vec{E}_h$ ) which depends on the cross product of the magnetic intensity,  $\vec{H}$ , and the current density,  $\vec{J}$ .

$$\vec{E}_h = R\vec{J} \times \vec{H}$$

Where R is called the Hall Coefficient

Now, let us consider a bar of semiconductor, having dimension, x, y and z. Let  $\vec{J}$  is directed along X and  $\vec{H}$  along Z then  $\vec{E}_h$  will be along Y.

Then we could write

$$R = \frac{V_h/y}{JH} = \frac{V_h}{IH}$$

Where  $V_h$  is the Hall voltage appearing between the two surfaces perpendicular to y and  $I=Jyz$

### Hall Effect experiment consists of the following:

1. Hall Probe (Ge Crystal) n & p-type
2. Hall Effect Set-up, DHE-21C
3. Electromagnet, EMU-50V
4. Constant Current Power Supply, DPS-50C
5. Digital Gaussmeter, DGM-202C
6. Computer Interface, SES-CAMM2

### Hall Probe (Ge Crystal)

Ge single crystal with four spring-type pressure contacts is mounted on a sunmica-decorated bakelite strip. Four leads are provided for connections with measuring devices.

### Technical details

Material	: Ge single crystal n or p-type as desired
Resistivity	: 8-10 $\Omega$ .cm
Contacts	: Spring type (solid silver)
Zero-field potential	: <1mV (adjustable)
Hall Voltage	: 25-35mV/10mA/KG

It is designed to give a clear idea to the students about Hall Probe and is recommended for class room experiment. A minor drawback of this probe is that it may require zero adjustment.

### Hall Effect Set-up, DHE-21C



DHE-21C is a high performance instrument of outstanding flexibility. The set-up consists of a digital millivoltmeter and a constant current power supply. The Hall voltage and probe current can be read on the same digital panel meter through a

# HEX-21C

## Hall Effect Experiment (with computer interface)

Page-2



interface unit, for computer control option.

### (i) Digital Millivoltmeter

Intersil 3½ digit single chip A/D Converter ICL 7107 have been used. It has high accuracy like, auto zero to less than  $10\mu\text{V}$ , zero drift of less than  $1\mu\text{V}/^\circ\text{C}$ , input bias current of  $10\text{pA}$  max. and roll over error of less than one count. Since the use of internal reference causes the degradation in performance due to internal heating, an external reference has been used. Digital voltmeter is much more convenient to use in Hall experiment, because the input voltage of either polarity can be measured.

#### Specifications

Range : 0-200mV (100mV minimum)  
Accuracy :  $\pm 0.1\%$  of reading  $\pm 1$  digit

### (ii) Constant Current Power Supply

This power supply, specially designed for Hall Probe, provides 100% protection against crystal burn-out due to excessive current. The supply is a highly regulated and practically ripple free dc source.

#### Specifications

Current : 0-20mA  
Resolution :  $10\mu\text{A}$   
Accuracy :  $\pm 0.2\%$  of the reading  $\pm 1$  digit  
Load regulation : 0.03% for 0 to full load  
Line regulation : 0.05% for 10% variation

### Computer Interface, SES-CAMM

An interface (SES-CAMM) enables the user to operate the hall effect setup through a computer. the interface is attached to

any USB port and on activation a GUI shows the computer control, data storage and graph plotting of the experiment. Also included is the option for automatic computation of hall coefficient, carrier mobility and carrier density.



Datasheets of other sub units is available separately.

The experiment in complete in all respect.

# Hall Effect Experiment

HEX-RM-150

SES Instruments Pvt Ltd.

## Hall Effect Experiment (Research Model)



### Introduction

When a current-carrying conductor is placed in a magnetic field perpendicular to the current direction, a voltage develops transverse to the current. This voltage was first observed in 1879 by Edwin Hall and the effect is called Hall Effect.

The Hall effect has since led to a deeper understanding of the details of the conduction process. It can yield the density of the charge carriers as well as their sign. The hall voltage for p-carriers has opposite sign from that for n-carriers. Therefore if a semiconductor with p-type doping is gradually heated up, more and more electrons from its valence band will go to conduction band. As a result hall voltage would fall rapidly with temperature and even become zero or change sign. At the point of zero Hall Coefficient, it is possible to determine the ratio of mobilities  $b = m_e/m_h$ . The Hall coefficient inversion is a characteristic of only p-type semiconductors.

### Theory

As you are aware, a static magnetic field has no effect on charges unless they are in motion. When the charges flow, a magnetic field directed perpendicular to the direction of flow produces a mutually perpendicular force on the charges. When this happens, electrons and holes will be separated by opposite forces. They will in turn produce an electric field ( $E_h$ ) which depends on the cross product of the magnetic intensity,  $H$ , and the current density,  $J$ .

$E_h = RJ \times H$  where  $R$  is called the Hall Coefficient

Now, let us consider a bar of semiconductor, having dimension,  $x$ ,  $y$  and  $z$ . Let  $J$  be directed along  $X$  and  $H$  along  $Z$  then  $E_h$  will be along  $Y$ .

Then we could write

$$V_{h/y} \quad V_{h.z}$$

## Hall Effect experiment consists of the following

The set-up consists of the following.

### 1. Hall Probe (Ge: p-type), HPP-RM-33

Ge single crystal with four spring type pressure contacts is mounted on a glass-epoxy strip. Leads are provided for connections with the current source and Hall voltage measuring devices.

#### Oven

It is a small oven which could be easily mounted over the crystal or removed if required.

#### Temperature Sensor

Cromel-Alumel thermocouple with its junction at a distance of 1 mm from the crystal.

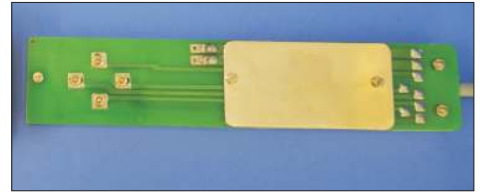

### 2. Hall Probe (without sample), HPP-RM-33NS

Same Hall Probe at HPP-33, except that it comes without sample, to enable the user to mount their own sample.

### 3. Hall Probe (Ge Crystal), HPN-RM & HPP-RM

Ge single crystal with four spring-type pressure contacts is mounted on a sunmica-decorated bakelite strip. Four leads are provided for connections with measuring devices.

#### Technical details

Material : Ge single crystal n-type & p-type

Resistivity : 8-10 $\Omega$ .cm

Contacts : Spring type (solid silver)

Zero- Field potential : < 1mV (adjustable)

Hall Voltage : 25-35mV/10mA/KG



### 4. Hall Probe (Si Crystal), HPSi-RM

Si single crystal with four spring-type pressure contacts is mounted on a sunmica-decorated bakelite strip. Four leads are provided for connections with measuring devices.

#### Technical details

Material : Si single crystal n-type

Resistivity : 14-15 $\Omega$ .cm

Contacts : Spring type (solid silver)

Zero- Field potential : < 1mV (adjustable)

Hall Voltage : 25-35mV/10mA/KG

This probe is very similar to HPN-RM.



## 5. Hall Probe Bismuth

Bismuth strip with four spring-type pressure contacts is mounted on a sunmica-decorated bakelite strip. Separate leads are provided for connections with measuring devices.

Technical details

Material : Bismuth

Resistivity :  $1.29 \times 10^{-4} \Omega \cdot \text{cm}$

Contacts : Spring type (solid silver)

Zero-field potential :  $< 1 \text{ mV}$  (adjustable)

Hall Voltage :  $25\text{-}35 \text{ mV}/10 \text{ mA}/\text{KG}$



## 5. Hall Probe (without sample), HP10-RM

Same Hall Probe at HPN-RM, except that it comes without sample, to enable the user to mount their own sample of  $10 \times 10 \text{ mm}$  size.

## 6. Hall Probe (without sample), HP05-RM

Same Hall Probe at HPN-RM, except that it comes without sample, to enable the user to mount their own sample of  $5 \times 5 \text{ mm}$  size.

## 7. Hall Effect Set, DHE-RM-150

### (a) Digital Millivoltmeter

#### Specifications

Range :  $1 \text{ mV}$ ,  $10 \text{ mV}$ ,  $100 \text{ mV}$ ,  $1 \text{ V}$   
&  $10 \text{ V}$  with 100% over-ranging.

Resolution :  $1 \mu\text{V}$

Accuracy :  $\pm 0.2\% \pm 1$  digit

Stability : Within  $\pm 1$  digit

Input Impedance :  $> 1000 \text{ M}\Omega$   
( $10 \text{ M}\Omega$  on  $10 \text{ V}$  range)

Display :  $3\frac{1}{2}$  digit, 7 segment  
LED with autopolarity and  
decimal indication



### (b) Constant Current Power Supply

#### Specifications

Range :  $0\text{-}20 \text{ mA}$ ,  $0\text{-}200 \text{ mA}$

Resolution :  $10 \mu\text{A}$

Accuracy :  $\pm 0.25\%$  of reading  $\pm 1$  digit

Display :  $3\frac{1}{2}$  digit, 7 segment LED with autopolarity and decimal indication

5. Electromagnet, EMU-75T (Refer datasheet for specifications)

6. Constant Current Power Supply, DPS-175-C2 (Refer datasheet for specifications)

7. Digital Gaussmeter, DGM-202-C1 (Refer datasheet for specifications)

## Optional Attachments

This model of Hall Effect Experiment may be connected to a computer for data logging purposes. Necessary hardware and software are available in HEX-RM-150C model. You may order these separately also, as and when required.

# HEM-01

## Hall Effect in Metal

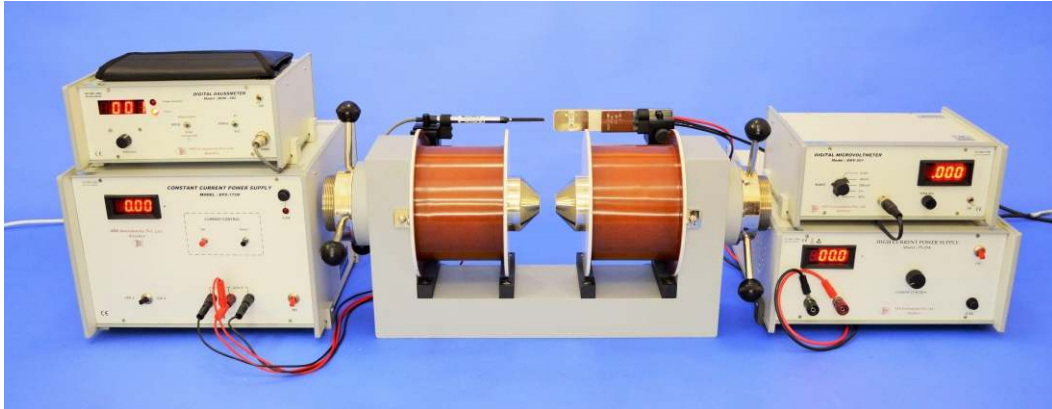

Hall Effect enables the charge carrier concentration and mobility to be determined by experiment. Direction of the Hall Voltage in silver indicates negative charge carriers, which is in agreement with concepts of the model of the 'free electron gas'. Limitations of this model are shown by the so called 'abnormal Hall Effect' of tungsten. The experiment carried out under identical conditions for tungsten show the Hall Voltage to have about same magnitude but opposite direction as in silver.

This can be explained by the 'Energy Band diagram'. The tungsten atom has ..... $5s^2 5p^6 5d^4 6s^2$  electronic structure. When the atoms come close together to form the solid, the close lying states  $5d$  and  $6s$  broaden into bands, with  $s$  band broadening considerably more than the  $d$  band. This is because of the larger size of the  $s$  orbital. The figure schematically shows the allowed energies as a function of the interatomic distance. The number of allowed states is ten per atom in the  $d$  band and two in the  $s$  band. In tungsten

there are six electrons to be shared between these two bands. The result is that at the interatomic distance in tungsten there are holes in the  $d$  band and electrons in the  $s$  band, making tungsten predominantly a hole conductor. This sort of mixed (electrons and holes) conduction is a general characteristic of transition metals. The apparatus consists of the following:

### a) Hall Probes-Silver(HP-Ag)

#### Technical Details

Material	: Silver(8X6X0.05 mm)
Contacts	: Press Type for current Spring type for Voltage
Hall Voltage	: ~17 mV/10A/10KG

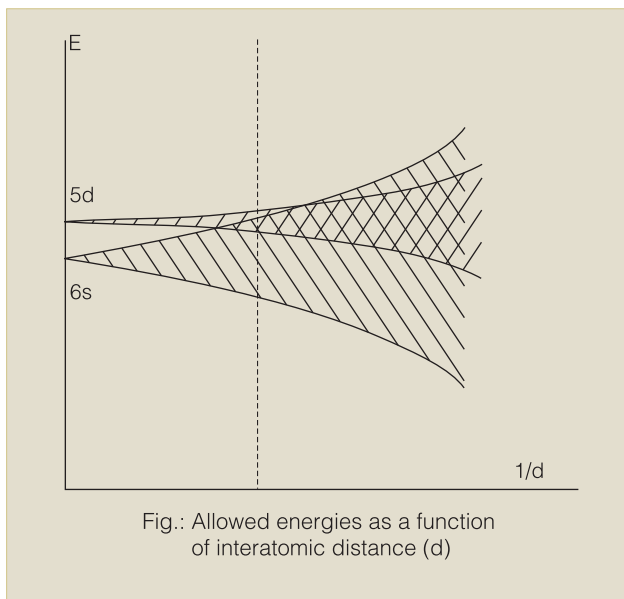
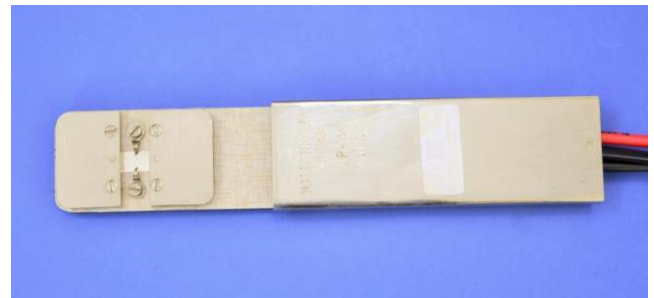

Fig.: Allowed energies as a function of interatomic distance (d)

### b) Hall Probe-Tungsten (HP-W)

#### Technical Details

Material	: Tungsten Strip (8 x 6 x 0.05 mm)
Contacts	: Press type for current Spring Type for Voltage
Hall Voltage	: ~15 mV/10A/10KG

# HEM-01

## Hall Effect in Metal

Page-2

**c) High Current Power Supply, Model PS-20A**

**Specification**

Range : 0-20A continuously variable  
Accuracy :  $\pm 0.5\%$   
Regulation :  $\pm 0.5\%$  for  $\pm 10\%$  variation of mains  
Display :  $3\frac{1}{2}$  digit, 7 Segment LED

**d) Digital Microvoltmeter, DMV-001**

It is a very versatile multipurpose instrument for the measurement of low dc voltage. It has 5 decade ranges from 1mV to 10mv with 100% over-ranging. For better accuracy and convenience, readings are directly obtained on  $3\frac{1}{2}$  digit DPM (Digital Panel Meter).

**Specifications**

Range : 1mV, 10mV, 100mV, 1V & 10V with 100% over-ranging.  
Resolution :  $1\mu\text{V}$   
Accuracy :  $\pm 0.2\% \pm 1$  digit  
Stability : Within  $\pm 1$  digit  
Input Impedance :  $> 1000\text{M}\Omega$  ( $10\text{M}\Omega$  on 10V range)  
Display :  $3\frac{1}{2}$  digit, 7 segment LED with autopolarity and decimal indication

**e) Electromagnet, Model EMU-75T**

**Specification**

Pole Pieces : 75mm tapered to 25mm  
Mag. Field :  $17\text{KG} \pm 5\%$  at 10mm airgap  
Energising Coils : Two of approx. 13 each  
Power : 0-90Vdc, 3A, for coils in series  
0-45Vdc, 6A, for coils in parallel

**f) Constant Current Power Supply, DPS-175M**

**g) Gaussmeter, DGM-202**

The experiment is complete in all respect.

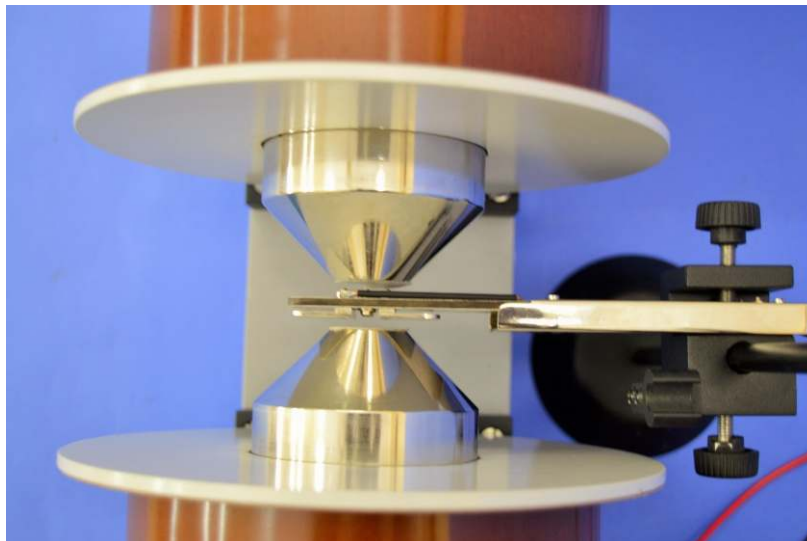
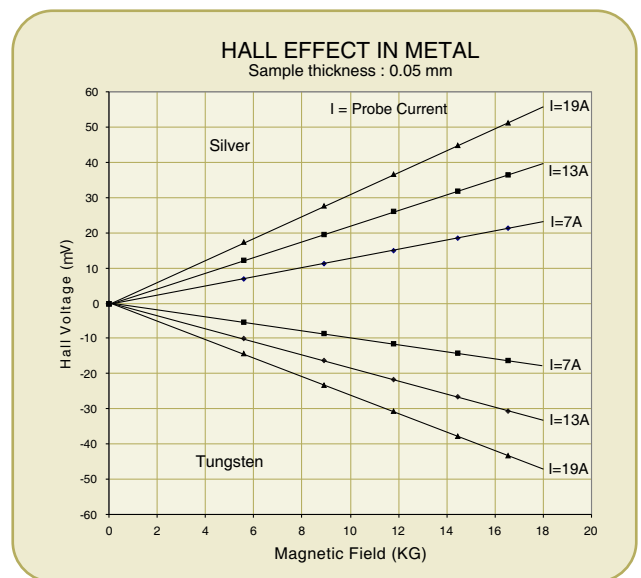

# Hall Effect Setup

HEX-33

SES Instruments Pvt Ltd.

## Dependence of Hall Coefficient on Temperature



### Description

The Hall voltage for p-carriers has opposite sign from that for n-carriers. Therefore if a semiconductor with p-type doping is gradually heated up, more and more electrons from its valence band will go to conduction band. As a result hall voltage would fall rapidly with temperature and even become zero or change sign. At the point of zero Hall Coefficient, it is possible to determine the ratio of mobilities  $b = m_e/m_h$ . The Hall coefficient inversion is a characteristic of only p-type semiconductors.

The set-up consists of the following. The Hall Probe comes complete with

#### 1. Hall Probe (Ge: p-type), HPP-33

Ge single crystal with four spring type pressure contacts is mounted on a glass-epoxy strip. Leads are provided for connections with the current source and Hall voltage measuring devices.

#### Oven

It is a small 12W oven mounted over the crystal for heating from ambient to 100 C.

#### Temperature Sensor

Cromel-Alumel thermocouple with its junction at a distance of 1 mm from the crystal.

#### 2. Hall Effect Set-up :DHE-33

The set-up, DHE-33 consists of two sub units to handle the probe parameters (probe current and hall

A constant current source (0-20mA) having a resolution of  $10\mu\text{A}$ , the hall voltage is measured by a high input resistance millivoltmeter in the range 0-200mV having a resolution of 100mV. The Probe. Current and hall voltage are both displayed on a 16 x 4 line LCD display. The sample temperature is controlled by a microcontroller based PWM heater current source. Thermo emf of the thermocouple is converted into temperature and is displayed on the same 16 x 4 line LCD display on the panel. Temperature range is ambient to 100 C and resolution is 1 C.

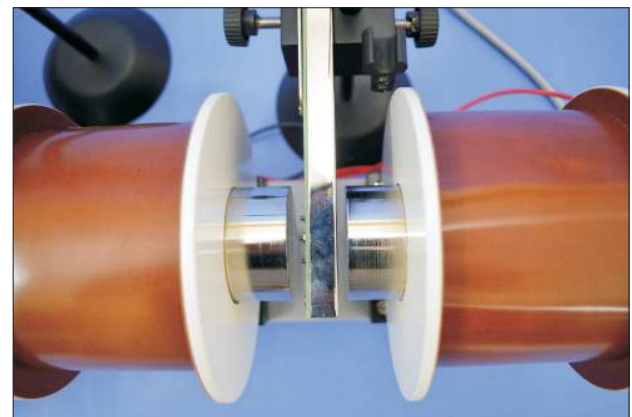

3. Electromagnet, EMU-50V  
(Refer datasheet for specifications)
4. Constant Current Power Supply, DPS-50/  
DPS-50-C1 (Refer datasheet for specifications)
5. Digital Gaussmeter, DGM-202/  
DGM-202-C1/ DGM-102 (Refer datasheet for specifications)

### Optional

Computer connectivity along with required hardware and software are optional and can be ordered as required.

*The experiment is complete in all respect.*

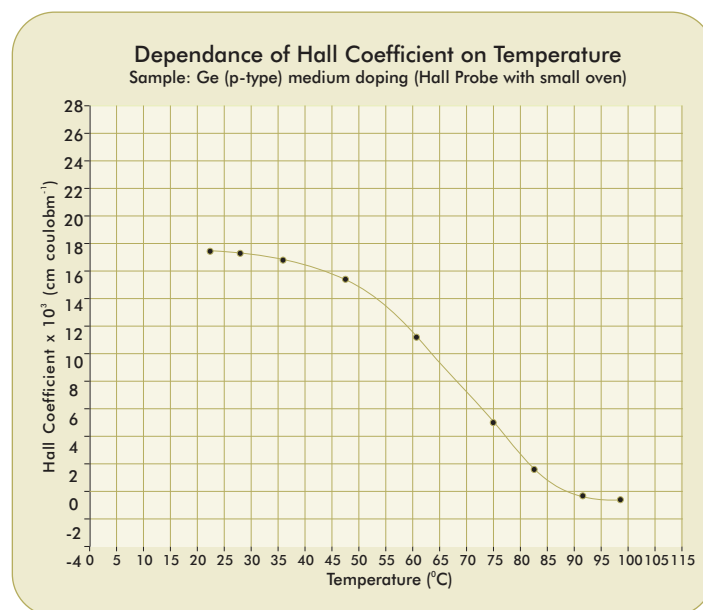

# Hall Effect Setup

HEX-33C

SES Instruments Pvt Ltd.

## Dependence of Hall Coefficient on Temperature



### Description

The Hall voltage for p-carriers has opposite sign from that for n-carriers. Therefore if a semiconductor with p-type doping is gradually heated up, more and more electrons from its valence band will go to conduction band. As a result hall voltage would fall rapidly with temperature and even become zero or change sign. At the point of zero Hall Coefficient, it is possible to determine the ratio of mobilities  $b = m_e/m_h$ . The Hall coefficient inversion is a characteristic of only p-type semiconductors.

The set-up consists of the following. The Hall Probe comes complete with

#### 1. Hall Probe (Ge: p-type), HPP-33

Ge single crystal with four spring type pressure contacts is mounted on a glass-epoxy strip. Leads are provided for connections with the current source and Hall voltage measuring devices.

#### Oven

It is a small 12W oven mounted over the crystal for heating from ambient to 100 C.

#### Temperature Sensor

Cromel-Alumel thermocouple with its junction at a distance of 1 mm from the crystal.

#### 2. Hall Effect Set-up :DHE-33

The set-up, DHE-33 consists of two sub units to handle the probe parameters (probe current and hall

A constant current source (0-20mA) having a resolution of  $10\mu\text{A}$ , the hall voltage is measured by a high input resistance millivoltmeter in the range 0-200mV having a resolution of 100mV. The Probe. Current and hall voltage are both displayed on a 16 x 4 line LCD display. The sample temperature is controlled by a microcontroller based PWM heater current source. Thermo emf of the thermocouple is converted into temperature and is displayed on the same 16 x 4 line LCD display on the panel. Temperature range is ambient to 100 C and resolution is 1 C.



3. Electromagnet, EMU-50V  
(Refer datasheet for specifications)

4. Constant Current Power Supply, DPS-50-C1  
(Refer datasheet for specifications)

5. Digital Gaussmeter, DGM-202-C1  
(Refer datasheet for specifications)

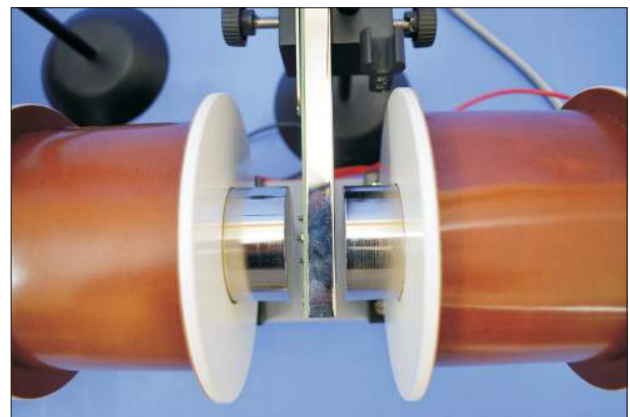

*In addition to the above, this Hall Effect Experiment may be connected to a computer for data logging purposes. Necessary hardware and software are included in the system.*

*The experiment is complete in all respect.*

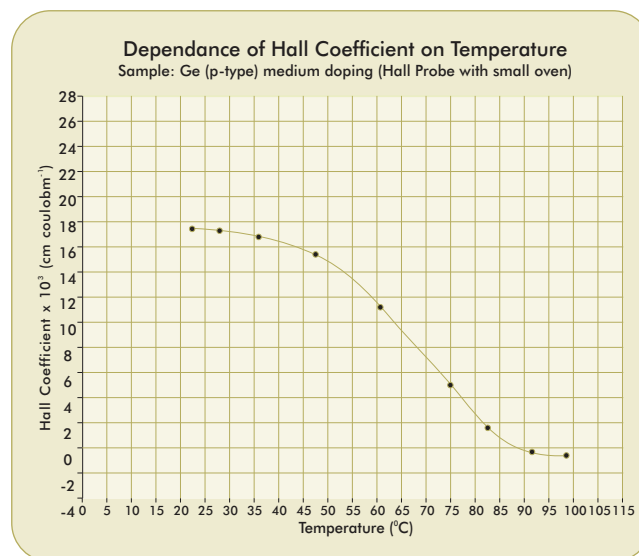

# QTX-01

## Quinck's Tube Method

### Apparatus For The Measurement of Susceptibility of Paramagnetic Solution by Quinck's Tube Method



#### Introduction

It was established by Faraday in 1845 that magnetism is universal property of every substance. He classified all magnetic substances into two classes, viz., paramagnetic and diamagnetic. Weber, later on, tried to explain para and diamagnetic properties on the basis of molecular currents. The molecular current gives rise to the intrinsic magnetic moment to the molecule, and such substances are attracted in a magnetic field, and called paramagnetics. The repulsion of diamagnetics is assigned to the induced molecular current and its respective reverse magnetic moment. The force acting on a substance, either of repulsion or attraction, can be measured with the help of an accurate balance in case of solids or with the measurement of rise in level in narrow capillary in case of liquids. The force depends on the susceptibility  $K$ , of the material, i.e., on ratio of intensity of magnetisation to magnetising field ( $I/H$ ). Evidently it refers to that quantity of substance by virtue of which bodies get magnetised. Quantitatively it refers to the extent of induced magnetisation in unit field. If the force on the substance and field are measured, the value of susceptibility can be calculated. The value of the susceptibility  $K$  of liquid aqueous solution of a paramagnetic substance in air is given by a well know expression:

$$K = \frac{2(\rho - \sigma)gh}{H^2}$$

where  $\rho$  is the density of the liquid or solution  
 $\sigma$  is the density of air  
 $g$  is the acceleration due to gravity  
 $h$  is the height through which column rises on switching on the field  
 $H$  is the magnetic field at the centre of pole pieces

#### Procedure

The apparatus consists of U-shaped tube known as Quinck's tube. One of the limb of the tube is wide and the other one narrow. The experimental liquid or solution is filled in the tube and is placed in such a way that the meniscus of the liquid in narrow limb is at the centre of the magnetic field. The level of the liquid in the narrow tube is read by a travelling microscope when magnetic field is off. The magnetic field is switched on and the new raised level of the column is again read with the travelling microscope. The apparatus consists of the following:

- Quinck's tube with stand
- Sample:  $MnSO_4 \cdot 2H_2O$
- Digital Balance 500gms (LC:0.1gm)
- RD Bottle
- Mixing Bottle
- Electromagnet, Model: EMU-50T
- Constant Current Power Supply, Model: DPS-50
- Digital Gaussmeter, Model: DGM-102
- Travelling Microscope



# QTX-01

## Quinck's Tube Method

Page-2

### Travelling Microscope (Horizontal and Vertical)



The bed is of heavy casting, thoroughly aged, machined and is fitted with levelling screws. On the dovetail guide ways

slides the horizontal carriage which can be clamped at any position by means of a thumb screw. A second sliding carriage slides along a gun metal vertical pillar fitted on the horizontal carriage. The slow motion guide bars are made of sturdy material and the motion is very smooth.

#### Optics

- (i) True achromatic objective with 7.5cm focussing distance
- (ii) 10X Ramsden eyepiece with fine cross wire

#### Scale and Vernier

- (i) Horizontal scale: 20cm divided at 0.5mm interval
- (ii) Vertical scale: 15cm divided at 0.5mm interval
- (iii) Venier scales: 50 divisions with a least count of 0.01mm

The setup is complete in all respect

For details of other subunits, kindly refer to their respective datasheets

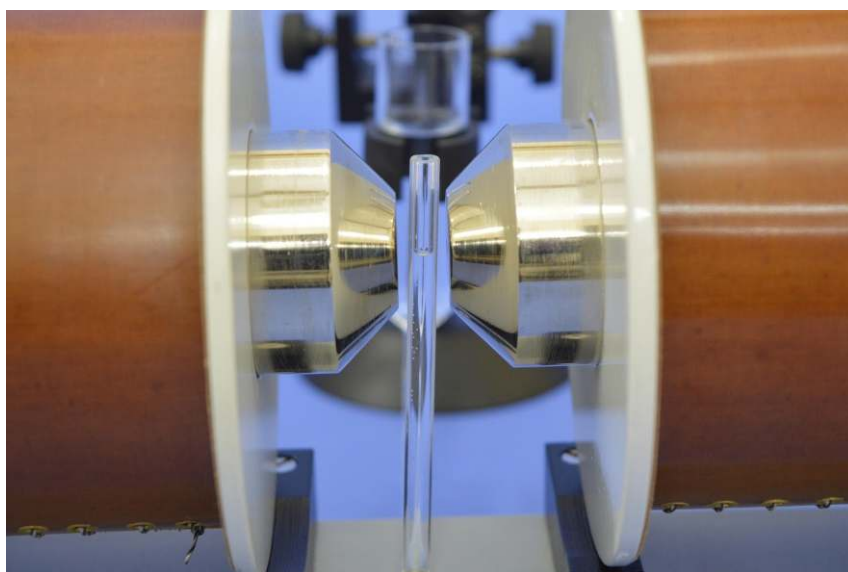

# GMX-01

## Gouy's Method

### Apparatus for Measurement of Susceptibility of Paramagnetic Solids by Gouy's Method

In the Gouy's method of susceptibility measurement, the solid sample in the form of a long cylinder (area of cross section  $A$ ) is hung from the pan of a balance and is placed such that one end of the sample is between the pole-pieces of the magnet (field  $H$ ) and the other one is outside the field. The force exerted on the sample by the inhomogeneous magnetic field is obtained by measuring the apparent change ( $\Delta m$ ) in the mass of the sample. The susceptibility  $\chi$  is given by

$$\chi = 2\Delta m g / AH^2$$

If the sample is in the form of powder, it is filled in a long nonmagnetic tube which is then suspended from the pan of the balance.

The set up consists of the following:

**(a) Scientific Balance, KSB-07**

- Capacity : 200 gms
- Sensitivity : 1/10 mg. by vernier
- Beam : Hard Bronze/ Brass
- Arrestment : Circular, falling away type
- Air Damping : Very quick and positive, beam coming to rest in 2-3 sec
- Chainomatic Device : A gold plated chain is suspended from the beam with its other end screwed on the Device rotating drum on which a scale graduated from 0 to 10 div each division representing 1mg is installed. By the movement of this scale before a vernier, reading upto 1/10th mg is taken

**(b) Sample in the form of a long rod:** Set of samples

**(c) Electromagnet, Model EMU-75T**

- Pole Pieces : 75mm tapered to 25mm
- Mag. Field : 20KG mm airgap
- Energising Coils : Two of approx. 13 $\Omega$  each
- Power : 0-90Vdc, 3A, for coils in series

- 0-45Vdc, 6A, for coils in parallel
- (d) Constant Current Power Supply, Model DPS-175**  
(specifications as per datasheet)
- (e) Gaussmeter, Model DGM-202 or DGM-102**  
(specifications as per datasheet)

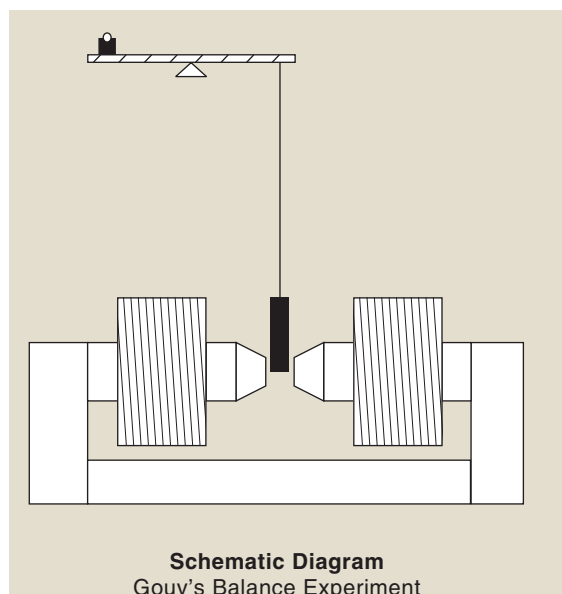

**Schematic Diagram**  
Gouy's Balance Experiment

# Gouy's Experiment

GMX-02 (50)

SES Instruments Pvt Ltd.

## Apparatus for Measurement of Susceptibility of Paramagnetic Solids by Gouy's Method

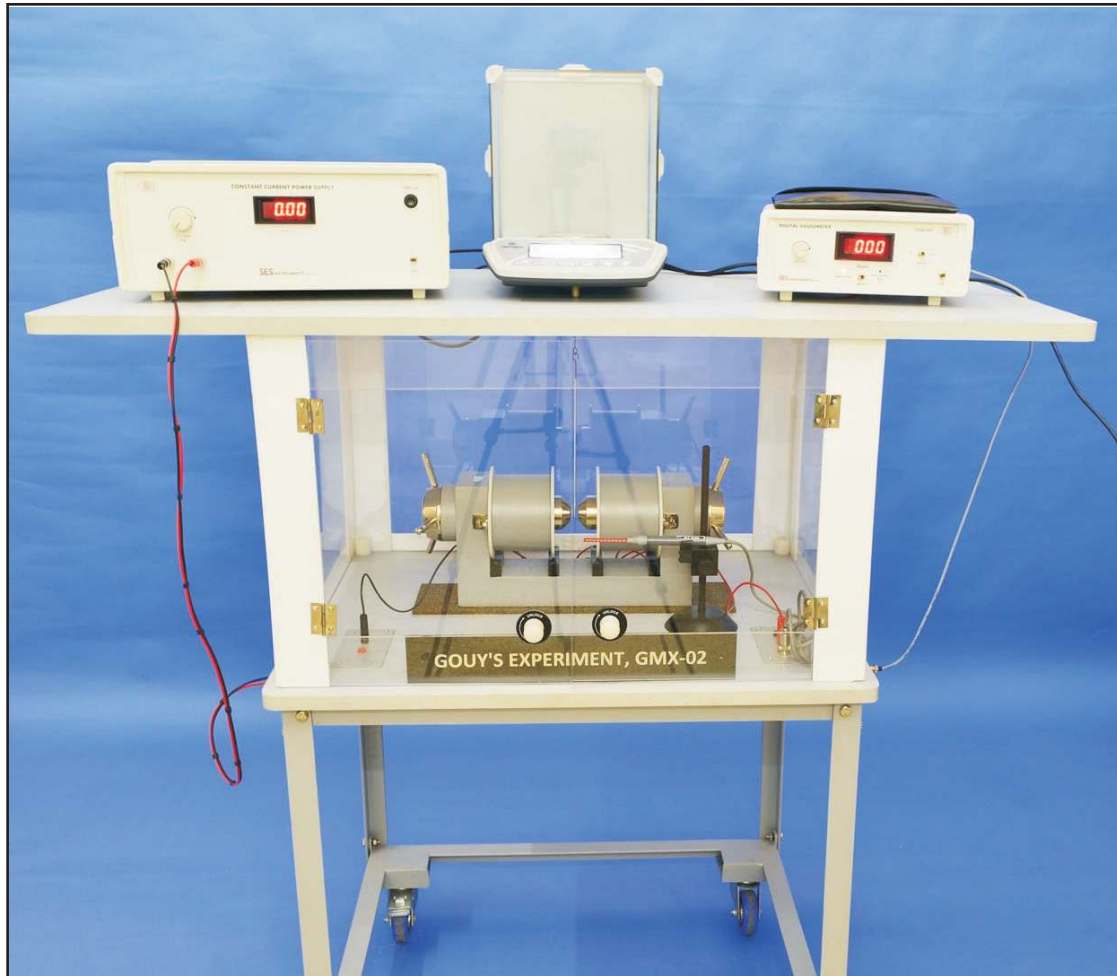

### Description

In the Gouy's method of susceptibility measurement, the solid sample in the form of a long cylinder (area of cross section  $A$ ) is hung from the pan of a balance and is placed such that one end of the sample is between the pole-pieces of the magnet (field  $H$ ) and the other one is outside the field. The force exerted on the sample by the inhomogeneous magnetic field is obtained by measuring the apparent change ( $\Delta m$ ) in the mass of the sample. The susceptibility  $c$  is given By  $2c = 2\Delta m g / AH$  If the sample is in the form of powder, it is filled in a long nonmagnetic tube which is then

## Description of Experimental Set-up

### 1. Digital Balance, CA-44

- Capacity : 40gms
- Readability : 0.0001gms
- Repeatability : (+/-) 0.1mg
- Linearity : (+/-) 0.2mg
- Pan Size : 80mm
- Standard bidirectional RS-232 interface
- Complete with weigh below hook feature suitable for Gouy's measurements



### 2. Samples

- Sample is provided with the step in the form of a long rod:
- Aluminium sample and Glass Tube.

### 3. Electromagnet, Model EMU-50T

- Field Intensity : 9.0KG at 10mm air-gap with tapered pole pieces
- Pole Pieces : 50mm diameter
- Energising Coils : Two, each with a resistance of about 3.0W
- Power Requirement : 0-30Vdc, 4A, if coils are connected in series
- Weight : 33Kg



### 4. Constant Current Power Supply, Model DPS-50

- Current Range : Smoothly adjustable from 0-4A
- Load Regulation : 0.1% for load variation from 0 to max.
- Line Regulation : 0.1% for  $\pm 110\%$  mains variation
- Display :  $3\frac{1}{2}$  digit, 7 segment LED DPM
- Power : 220V  $\pm 10\%$ , 50Hz

## 5. Gaussmeter, Model DGM-202

Resolution : 1 gauss at 2 kilogauss range

Range : 2KG and 20KG

Accuracy :  $\pm 0.5\%$

Temperature : Upto 40°C

Display : 3½ digit, 7 segment LED DPM with auto polarity and overflow indication

Power : 220V  $\pm 10\%$ , 50Hz

Transducer : Hall Probe-GaAs

Special Feature : Indicates the direction of the magnetic field



## 6. GMX-02 Trolley, Model GMX-TR2

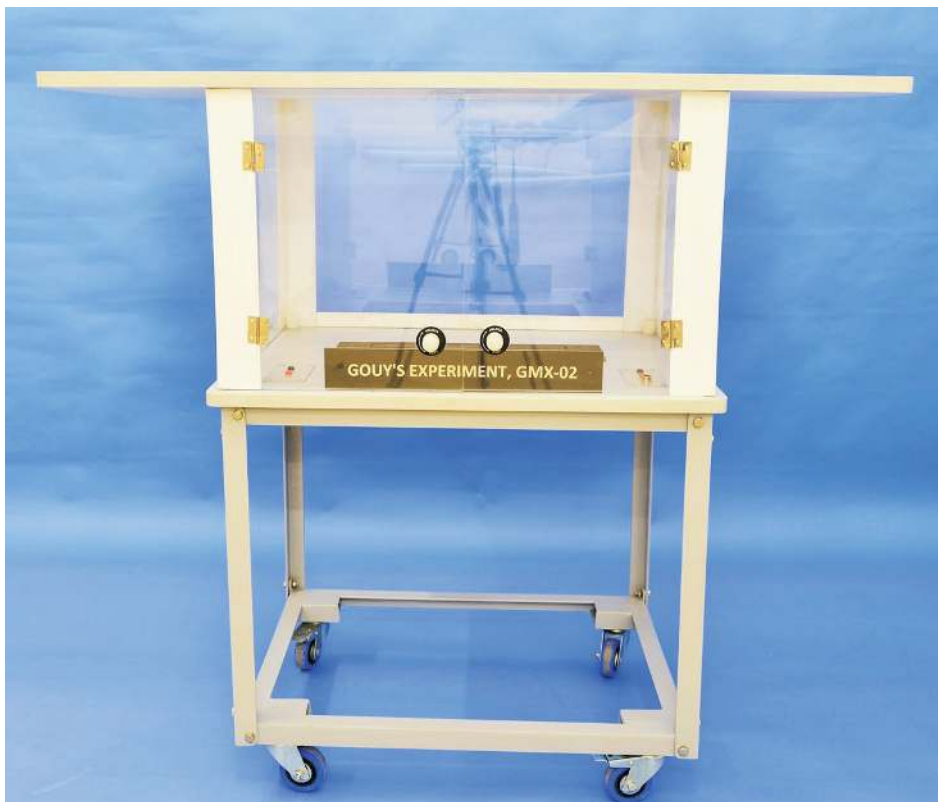

***The setup is complete in itself***

# GMX-02

## Gouy's Method

### Apparatus for Measurement of Susceptibility of Paramagnetic Solids by Gouy's Method

In the Gouy's method of susceptibility measurement, the solid sample in the form of a long cylinder (area of cross section  $A$ ) is hung from the pan of a balance and is placed such that one end of the sample is between the pole-pieces of the magnet (field  $H$ ) and the other one is outside the field. The force exerted on the sample by the inhomogeneous magnetic field is obtained by measuring the apparent change ( $\Delta m$ ) in the mass of the sample. The susceptibility  $\chi$  is given by

$$\chi = 2\Delta mg/AH^2$$

If the sample is in the form of powder, it is filled in a long nonmagnetic tube which is then suspended from the pan of the balance.

The set up consists of the following:

**(a) Digital Balance, CA-44**

Capacity : 40gms  
Readability : 0.0001gms  
Repeatability : (+/-) 0.1mg  
Linearity : (+/-) 0.2mg  
Pan Size : 80mm

Standard bidirectional RS-232 interface  
Complete with weigh below hook  
feature suitable for GMX-01 measurement

**(b) Sample in the form of a long rod:** Aluminium sample and Glass Tube

**(c) Electromagnet, Model EMU-75T**

Pole Pieces : 75mm tapered to 25mm  
Mag. Field : 20KG mm airgap  
Energising Coils : Two of approx. 13 $\Omega$  each  
Power : 0-90Vdc, 3A, for coils in series  
0-45Vdc, 6A, for coils in parallel

**(d) Constant Current Power Supply, Model DPS-175**  
(specifications as per datasheet)

**(e) Gaussmeter, Model DGM-202** (specifications as per datasheet)

**(f) GMX-02 Trolley, Model GMX-TR2**

The experiment is complete in all respect.

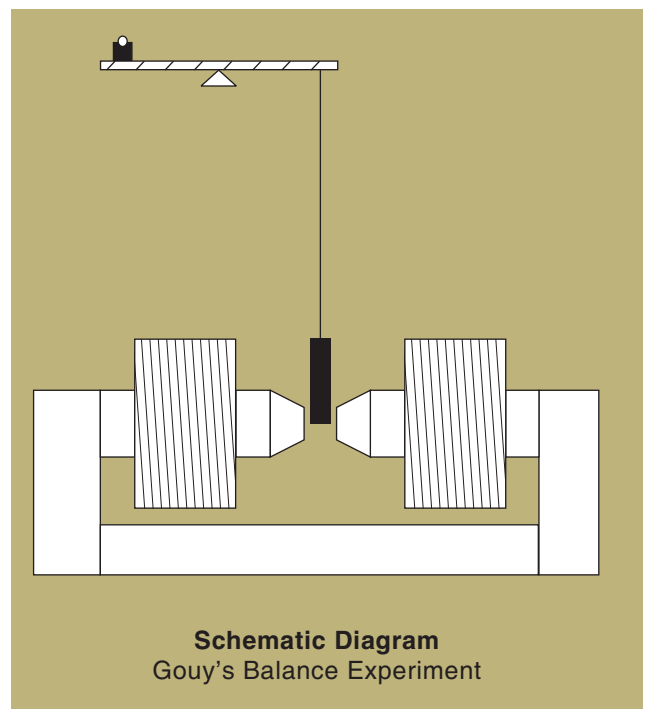
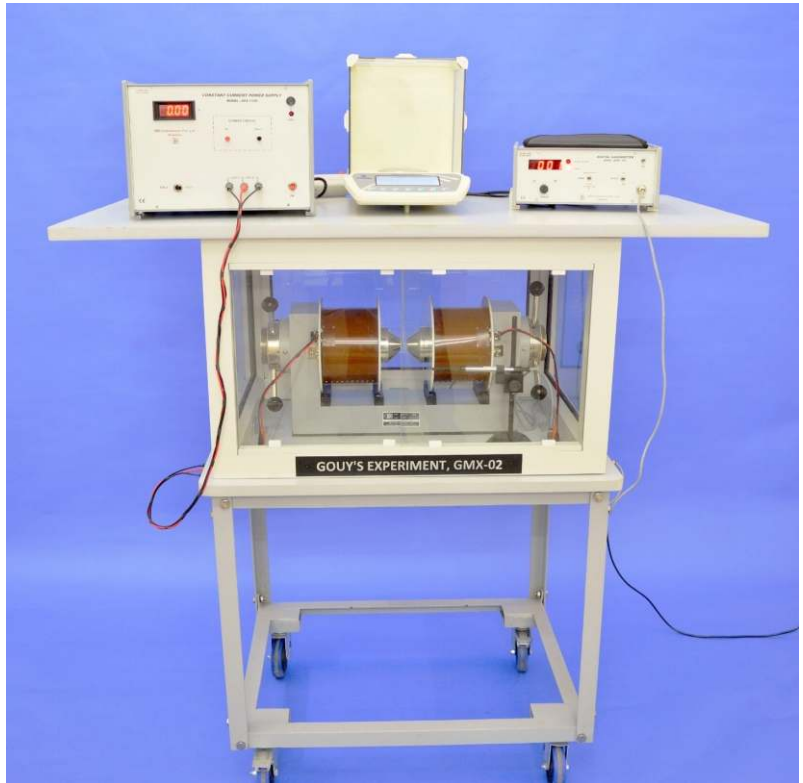

**Schematic Diagram**  
Gouy's Balance Experiment

# HLT-111

## Hysteresis Loop Tracer



- Measures magnetic parameters accurately
- Demagnetisation, eddy currents and sample cross-sectional area have been accounted for
- Capable of detecting the number of magnetic phase present in a sample

### Introduction

A precise knowledge of various magnetic parameters of ferromagnetic substances, viz. coercivity, retentivity, saturation magnetisation and hysteresis loss, and ability to determine them accurately are important aspects of magnetic studies.

The information about the aforementioned properties can be obtained from a magnetic hysteresis loop which can be traced by a number of methods in addition to the slow and laborious ballistic galvanometer method. Among the typical representatives of AC hysteresis loop tracers, some require the ring form of samples while others can be used with thin films, wires or even rock samples. Ring form samples are not always practically convenient to make while in others demagnetisation effects sometime become quite important. The present set-up can accept the samples of thin wires of different diameters. The demagnetisation effects, different diameters of samples and eddy currents (due to the conducting property of the material) has been taken into account within the design or graphically.

### Design Principle

When a cylindrical sample is placed coaxially in a periodically varying magnetic field the magnetisation in the sample also undergoes periodic variation. This variation is picked up by a coil, placed coaxially with the sample. For the uniform field  $H_a$  produced, the effective field  $H$  acting in the cylindrical sample will be

$$H = H_a - NM$$

$$\text{or } H = H_a - \frac{NJ}{\mu_0} \quad (1)$$

where  $M$  is magnetisation,  $N$  is normalised demagnetisation factor including  $4\pi$  and  $J$  is the magnetic polarisation defined by

$$B = \mu_0 H + J$$

with  $B = \mu H$  or  $\mu_0(H + M)$  as magnetic induction. The signal corresponding to the applied field,  $H_a$  can be written as

$$e_1 = C_1 H_a \quad (2)$$

where  $C_1$  is a constant

Further the flux linking with the pick-up coil of area  $A_c$  due to sample of area  $A_s$  will be

$$\phi = \mu_0 (A_c - A_s) H' + A_s B$$

where  $H'$  is the field in the excess area of the pick-up coil.

Under certain conditions this equation reduces to

$$\phi = \mu_0 A_c H + A_s J$$

The signal induced in the pick-up coil ( $e_2$ ) will be proportional to  $d\phi/dt$  which after integration yields

$$e_3 = C_3 \phi = C_3 \mu_0 A_c H + C_3 A_s J \quad (3)$$

Solving (1), (2) and (3) gives

$$C_1 C_3 A_c \left( \frac{A_s}{A_c} - N \right) J = C_1 e_3 - \mu_0 C_3 A_c e_1$$

$$C_1 C_3 A_c \left( \frac{A_s}{A_c} - N \right) J = C_3 A_s e_1 - \frac{N C_3 e_1}{\mu_0}$$

Based on these equations the electronic circuit has been designed to give values of  $J$  and  $H$  and hence the hysteresis loop. Further different magnetic phases present in the sample may also be identified by electronically manipulating the pick-up signal.

### Description of the set-up

The block diagram of the set-up is given next and a brief description now follows:

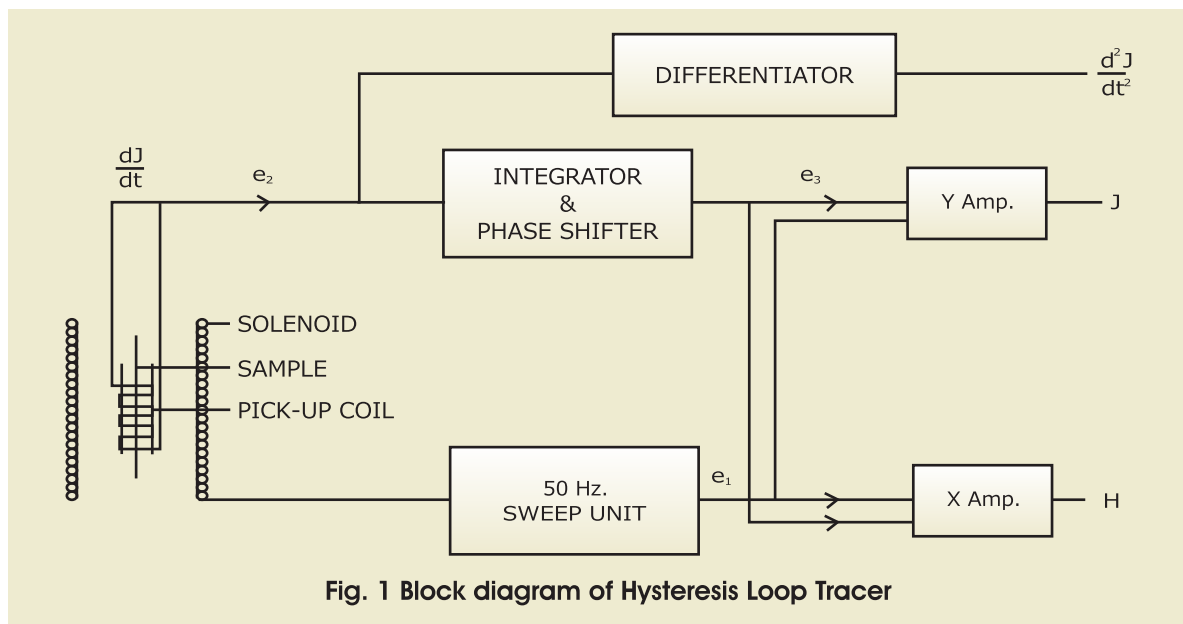

### Basic Circuit

The magnetic field has been obtained with an ac mains driven multilayered solenoid. This magnetic field has been calibrated with a Hall Probe for uniformity and correspondence with the magnetic field calculated through ac current passing in the solenoid. A small resistance in series with the solenoid serves the purpose of taking a signal  $e_1$  corresponding to H.

The signal  $e_2$  (corresponding to  $dJ/dt$ ) is taken from the pick-up coil placed at the centre of the solenoid and contains the sample. It is integrated and corrected for phase. This signal is then subtracted from the reference signal  $e_1$  and amplified to give the signal corresponding to J. The  $e_1$  signal is also subtracted from  $3e_3$  in correct ratio (to account for demagnetisation and area ratio) and amplified to give signal corresponding to H.

$e_2$  is also passed through the differentiator for getting signal corresponding to  $d^2J/dt^2$  which is used for phase identification.

### Applications

The following magnetic parameters can be measured by this set-up:

- Coercivity
- Retentivity
- Saturation magnetisation
- Various magnetic phase identification
- Hysteresis loss

The equipment is complete in all respect, including a set of samples (wires of Nickel, and different grades of iron etc.).

A Cathode Ray Oscilloscope will however be required.

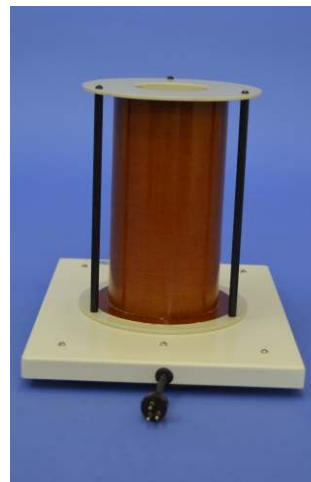
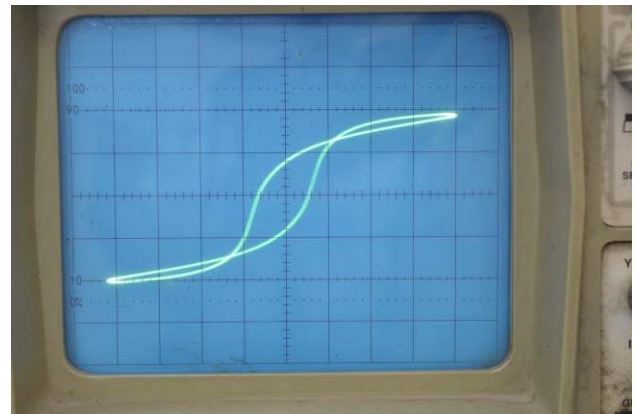

# HLT-111C

## Hysteresis Loop Tracer



- Measures magnetic parameters accurately
- Demagnetisation, eddy currents and sample cross-sectional area have been accounted for
- Capable of detecting the number of magnetic phase present in a sample
- Computer Interface provided

### Introduction

A precise knowledge of various magnetic parameters of ferromagnetic substances, viz. coercivity, retentivity, saturation magnetisation and hysteresis loss, and ability to determine them accurately are important aspects of magnetic studies.

The information about the aforementioned properties can be obtained from a magnetic hysteresis loop which can be traced by a number of methods in addition to the slow and laborious ballistic galvanometer method. Among the typical representatives of AC hysteresis loop tracers, some require the ring form of samples while others can be used with thin films, wires or even rock samples. Ring form samples are not always practically convenient to make while in others demagnetisation effects sometime become quite important.

The present set-up can accept the samples of thin wires of different diameters. The demagnetisation effects, different diameters of samples and eddy currents (due to the conducting property of the material) has been taken into account within the design or graphically.

### Design Principle

When a cylindrical sample is placed coaxially in a periodically varying magnetic field the magnetisation in the sample also undergoes periodic variation. This variation is picked up by a coil, placed coaxially with the sample.

For the uniform field  $H_0$  produced, the effective field  $H$  acting in the cylindrical sample will be

$$\begin{aligned} H &= H_0 - NM \\ \text{or } H &= H_0 - \frac{NJ}{\mu_0} \end{aligned} \quad (1)$$

where  $M$  is magnetisation,  $N$  is normalised demagnetisation factor including  $4\pi$  and  $J$  is the magnetic polarisation defined by

$$B = \mu_0 H + J$$

with  $B = \mu H$  or  $\mu_0(H + M)$  as magnetic induction. The signal corresponding to the applied field,  $H_a$  can be written as

$$e_1 = C_1 H_a \quad (2)$$

where  $C_1$  is a constant

Further the flux linking with the pick-up coil of area  $A_c$  due to sample of area  $A_s$  will be

$$\phi = \mu_0 (A_c - A_s) H' + A_s B$$

where  $H'$  is the field in the excess area of the pick-up coil.

Under certain conditions this equation reduces to

$$\phi = \mu_0 A_c H + A_s J$$

The signal induced in the pick-up coil ( $e_2$ ) will be proportional to  $d\phi/dt$  which after integration yields

$$e_3 = C_3 \phi = C_3 \mu_0 A_c H + C_3 A_s J \quad (3)$$

Solving (1), (2) and (3) gives

$$C_1 C_3 A_c \left( \frac{A_s}{A_c} - N \right) J = C_1 e_3 - \mu_0 C_3 A_c e_1$$

$$C_1 C_3 A_c \left( \frac{A_s}{A_c} - N \right) J = C_3 A_s e_1 - \frac{N C_1 e_3}{\mu_0}$$

Based on these equations the electronic circuit has been designed to give values of  $J$  and  $H$  and hence the hysteresis loop. Further different magnetic phases present in the sample may also be identified by electronically manipulating the pick-up signal.

### Description of the set-up

The block diagram of the set-up is given next and a brief description now follows:

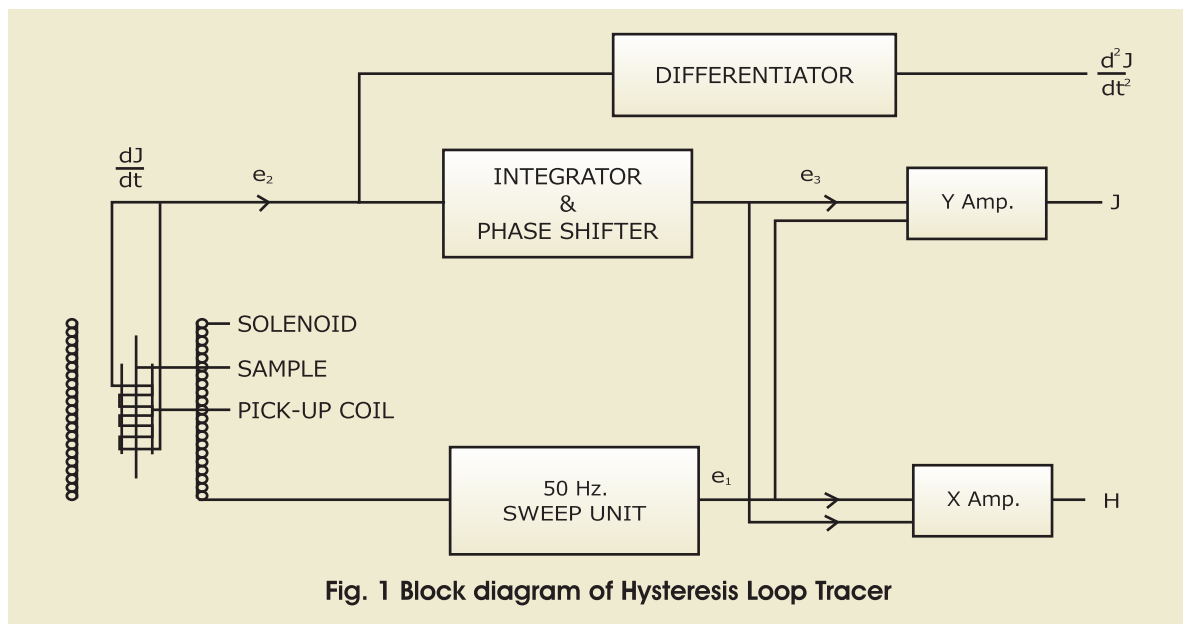

Fig. 1 Block diagram of Hysteresis Loop Tracer

### Basic Circuit

The magnetic field has been obtained with an ac mains driven multilayered solenoid. This magnetic field has been calibrated with a Hall Probe for uniformity and correspondence with the magnetic field calculated through ac current passing in the solenoid. A small resistance in series with the solenoid serves the purpose of taking a signal  $e_1$  corresponding to  $H$ .

The signal  $e_2$  (corresponding to  $dJ/dt$ ) is taken from the pick-up coil placed at the centre of the solenoid and contains the sample. It is integrated and corrected for phase. This signal is then subtracted from the reference signal  $e_1$  and amplified to give the signal corresponding to  $J$ . The  $e_1$  signal is also subtracted from  $3e_3$  in correct ratio (to account for demagnetisation and area ratio) and amplified to give signal corresponding to  $H$ .

$e_2$  is also passed through the differentiator for getting signal corresponding to  $d^2J/dt_2$ , which is used for phase identification.



### Computer Interface, SES-CAMM

This interface enables the user to get a plot of the B-H Loop on the computer screen as soon as a magnetic field is set soon the hardware. Procedure for initial setting and conduction of experiment are available through the software provided with the unit. In the end, data would be stored in the excel format.

### Applications

The following magnetic parameters can be measured by this set-up:

- Coercivity
- Retentivity
- Saturation magnetisation
- Various magnetic phase identification
- Hysteresis loss

The equipment is complete in all respect, including a set of samples (wires of Nickel, and different grades of iron etc.). A Cathode Ray Oscilloscope and a computer will however be required.

# Ferroelectric PE Loop Tracer

PEL-01C

SES Instruments Pvt Ltd.



## Introduction

Research in the area of ferroelectrics is driven by the market potential of next generation memories and transducers. Thin films of ferroelectrics and dielectrics are rapidly emerging in the field of MEMS applications. Ultrasonic micro-motors utilizing PZT thin films and pyroelectric sensors using micro-machined structures have been fabricated. MEMS are finding growing application in accelerometers for air bag deployment in cars, micro-motors and pumps, micro heart valves, which have reached the commercial level of exploitation in compact medical, automotive, and space applications. Extremely sensitive sensors and actuators based on thin film and bulk will revolutionize every walk of our life with Hi-Tech gadgets based on ferroelectrics. Wide spread use of such sensors and actuators have made Hubble telescope a great success story. New bulk ferroelectric and their composites are the key components for the defence of our air space, the long coastline and deep oceans.

## Measurement Technique

The commonly accepted criterion of ferroelectricity is a hysteresis loop. This is usually done with the help of a cathode ray oscilloscope. In this method, an alternating high voltage is applied and the stored charge is related to the instantaneous voltage. A large integrating capacitor (standard capacitor) is placed in series with the sample. The voltage across it measures the charge stored on the test sample and is conventionally displayed as the vertical deflection of the cathode ray oscilloscope. The applied voltage is displayed as the horizontal deflection.

Block diagram of our system is given in Fig 2. It has a provision to compensate conductive unwanted

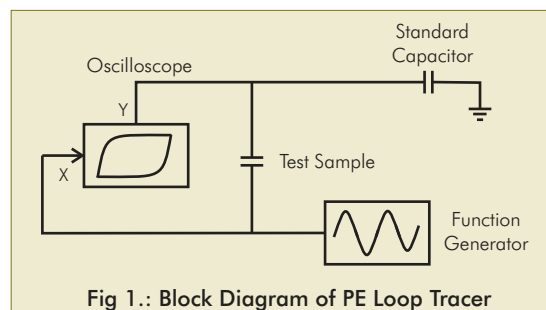
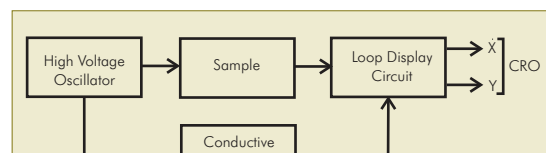

Fig 1.: Block Diagram of PE Loop Tracer



## Description of Experimental Set-up

### 1. Probes Arrangement

In this arrangement one probe is held fixed and the other is spring loaded for placing the sample as well as making the proper connection. All care has been taken to avoid voltage hazards and yet convenient to replace the sample. Provision has also been made for dipping the contacts in high voltage oil to avoid discharge due to high voltage. It also includes a furnace for determining Curie Temperature.

### 2. Sample

Barium Titanate ( $\text{BaTiO}_3$ ) pellet

### 3. Main Unit

- (i) High Voltage Oscillator
  - Amplitude: 0-10,000 Vpp
  - Frequency:  $\sim 100\text{Hz}$
  - Waveform: Low distortion sine wave
- (ii) Signal Processing Circuit

It contains front end amplifier, conductive and capacitive compensation circuit and finally appropriate signal conditioning to display on CRO.



### Application

Following measurements can be done by this setup

- Study the behaviour of maximum polarisation ( $P_m$ )
- Study the remnant polarization ( $P_r$ )
- Study the coercivity with electric field ( $E_c$ )
- Curie Temperature ( $T_c$ )
- Behaviour of  $E_c$ ,  $P_r$ ,  $P_m$  vs Temperature at Constant Electric Field

### Computer Connectivity

PE Loop Tracer Setup can be connected to a computer for acquiring data for data logging purposes. The data can be stored in excel file which can be used for further analysis. Software is menu driven and very easy to operate. All loops are visible on Computer Screen in real time.

Necessary hardware - SES-CAMM and its software is provided along with the setup.

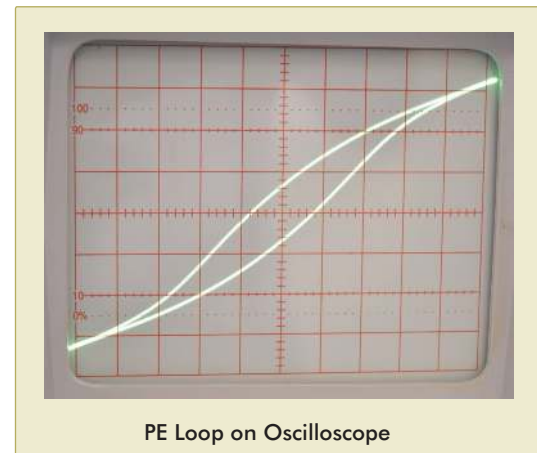

# PN-01

## P-N Junctions

### Study of the energy band-gap and diffusion potential of P-N Junctions

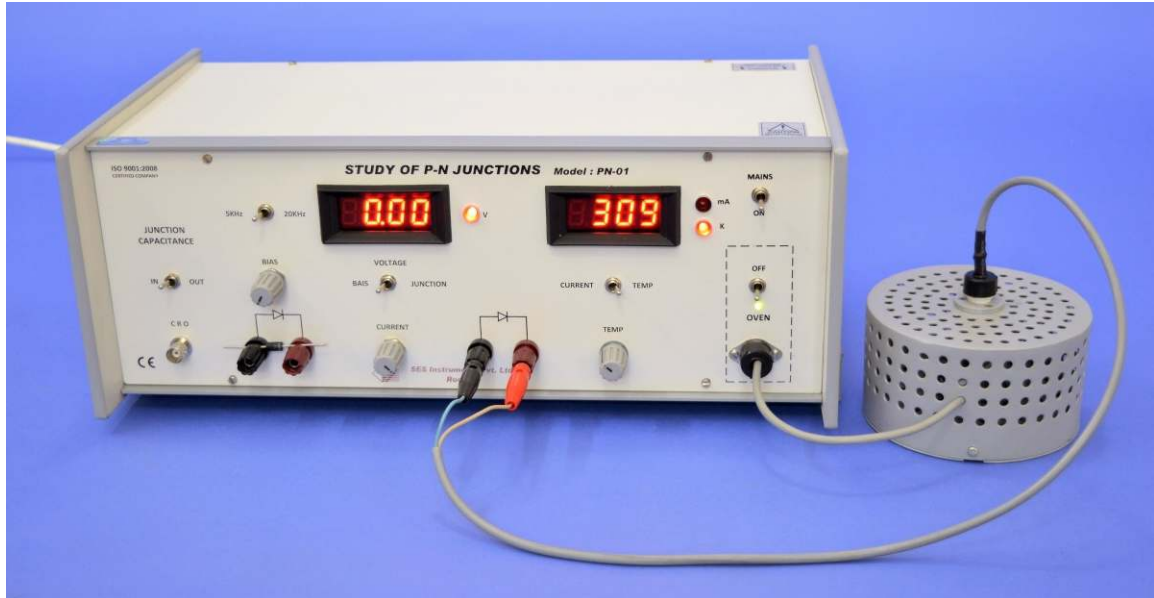

#### Experimental Determination of :

- Reverse saturation current  $I_0$  and material constant  $\eta$
- Temperature coefficient of junction voltage  $dV/dt$
- Energy band-gap  $V_{G_0}$
- Junction capacitance

#### Introduction

This is an advanced level experiment to be performed on commercially available diodes viz. germanium or silicon diodes, various types of LED's and also on the base-emitter/collector-base junctions of a transistor. The results of the experiments not only give the device characteristics but also provide an insight into the properties of the materials used in the fabrication of the junction. In the set-up, all the necessary instrumentation is integrated as a result of which a minimum of external connections need to be made by the user. A CRO is the only accessory that is required.

#### Experiments

Given below is a brief description of the experiments that may be performed.

#### (a) Reverse saturation current $I_0$ and material constant $\eta$

The magnitude of  $I_0$  is too small to be measured conveniently and further, it is a function of the applied voltage. The direct measurement of this current is therefore both difficult and erroneous. In the present set-up, readings for the forward V-I characteristics are obtained by 3½ digit DPM for a wide range of currents.

If, V and  $\ln I$  are plotted on a graph paper a straight line is

obtained. This line intersects the current ( $\ln I$ ) axis at  $\ln I_0$  and its slope  $\Delta V/\Delta \ln I$  may be solved to compute  $\eta$ . (fig.1)

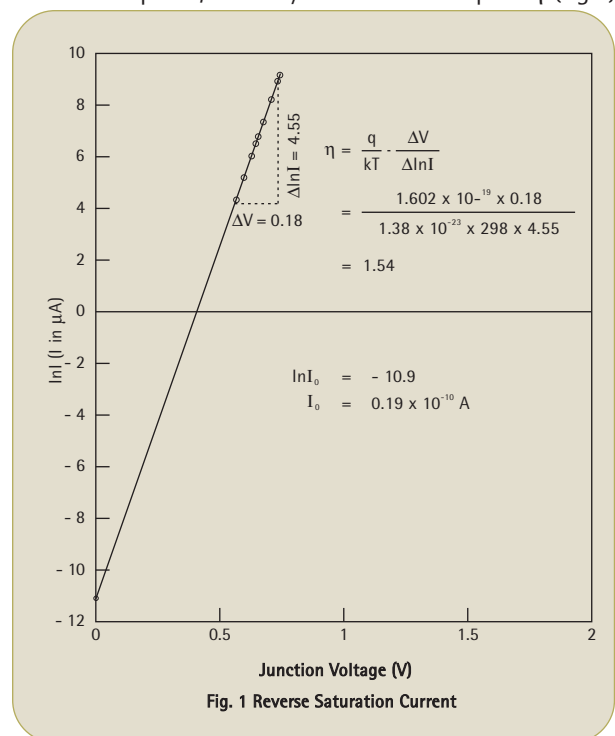

#### (b) Energy band-gap and temperature coefficient of the junction voltage

The P-N junction under test is kept in a small, fast temperature controlled oven. The temperature is

adjustable in the range from room temperature to about 80°C. From the readings of the temperature and junction voltage on digital instruments provided on the panel, the temperature coefficient and energy band-gap are computed. (fig.2)

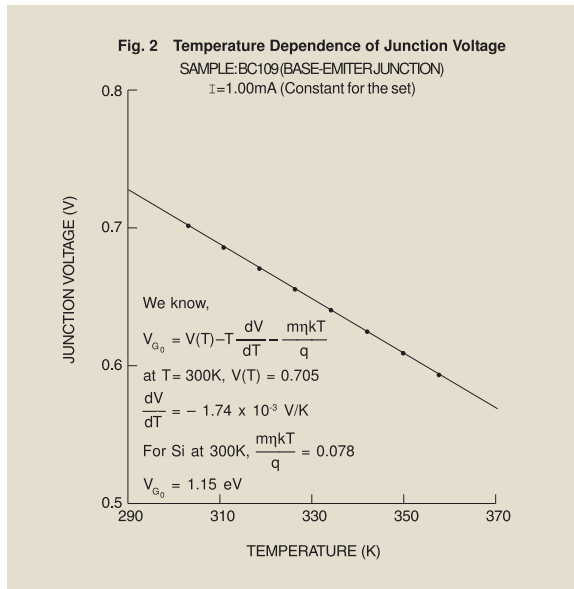

### (c) The Junction Capacitance

The junction capacitance of a typical diode varies in the range 10pf-100pf approximately, as a non-linear function of the reverse voltage. This parameter though important in high frequency circuits, is difficult to measure because of its small value. In the present set-up, the output  $V_1$  and  $V_2$  at two frequencies  $f_1$  &  $f_2$ , where  $f_2 > f_1$ , are obtained at different values of bias voltage to

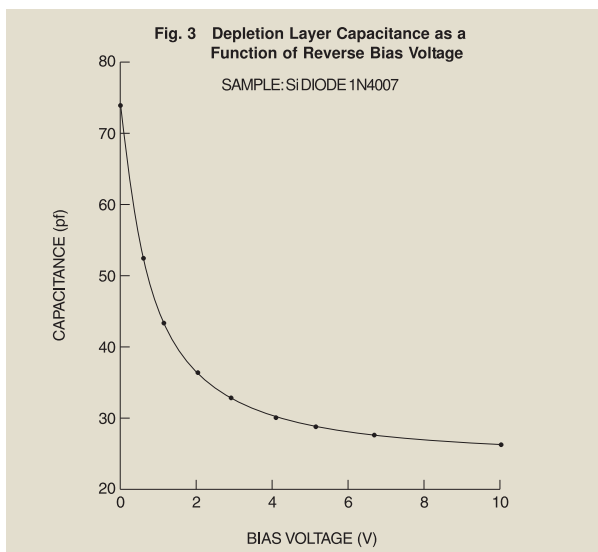

compute the junction capacitance. A typical graph between bias voltage and junction capacitance is shown in fig.3.

The experimental set-up consists of the following

#### (1) Study of P-N Junction, Model PN-1

- 3½ digit DPM for current/temperature measurements.
- 3½ digit DPM for bias voltage/junction voltage measurements.
- Two parts to connect the diode - one for experiment 1 & 2 and other for experiment 3.
- Two fixed frequency oscillators (5KHz & 20KHz) with the same output (200 mV).

#### (2) Fast temperature controlled oven with sensor

#### (3) Set of samples

- Transistor BC109 (base-emitter)-Si
- Transistor AC126 (base-emitter)-Ge
- Diode 1N 5408/1N 4007-Si

The unit is supplied complete with a detailed instruction manual. Sufficient theoretical description is included for a proper understanding. This is followed by a step-by-step procedure and a typical set of readings and results.

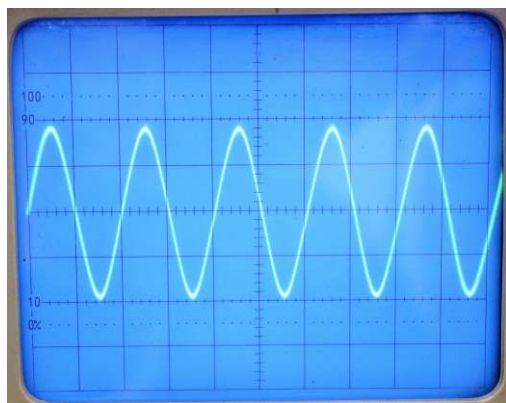
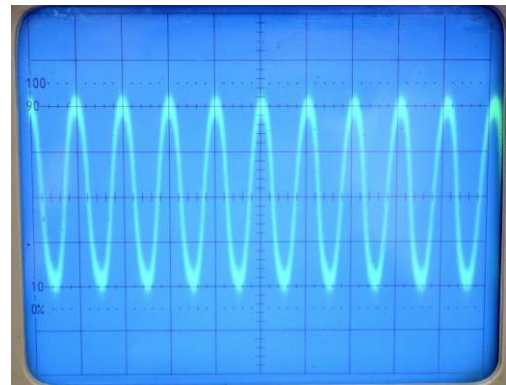

Complete in all respect, except a CRO for capacitance measurement. Typical results obtained are shown in fig. no. 1, 2 & 3.

# DCBC-01

## Diodes Characteristics & Boltzman Constant



- Forward and reverse characteristics of Ge, Si diodes and LEDs
- Study of Zener diode characteristics
- CRO display of forward and reverse characteristics
- Determination of Boltzman Constant

The set-up is provided with a booklet which contains its theory of operation, description, suggestions and discussion of the experiments that may be performed with it.

The experimental set-up consists of the following:

1. Diodes: Rectifier-4007 (Si), Signal diode-1N34 (Ge), Zener 4.7V, LED and transistor BC-109
2. 3½ digit DPM which can measure diode voltage and current through op-amp circuit. This provides near ideal measurements.
3. Circuit to display forward/reverse characteristics of the diodes on a double trace CRO.
4. IC regulated internal power supplies

The experimental set-up is complete in all respect, except a measuring CRO.

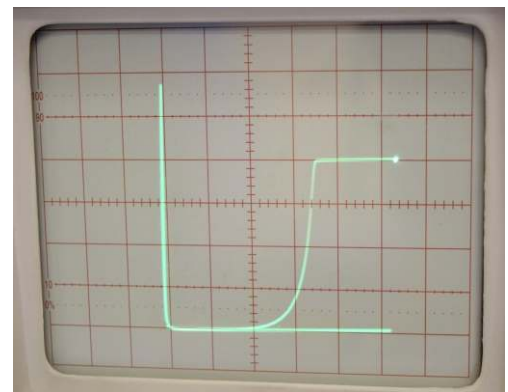

CRO Display

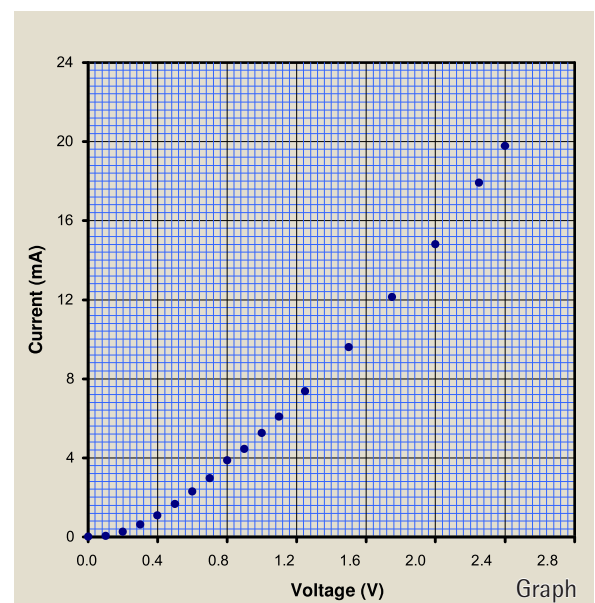

Graph

# Characteristics of Photo Devices

PD-01

SES Instruments Pvt Ltd.

- LDR, Photodiode, Phototransistor and Solar Cell studies
- Variable intensity white light source
- Four range current meter
- I-V and P-V characteristics of Solar Cell. Fill factor evaluation

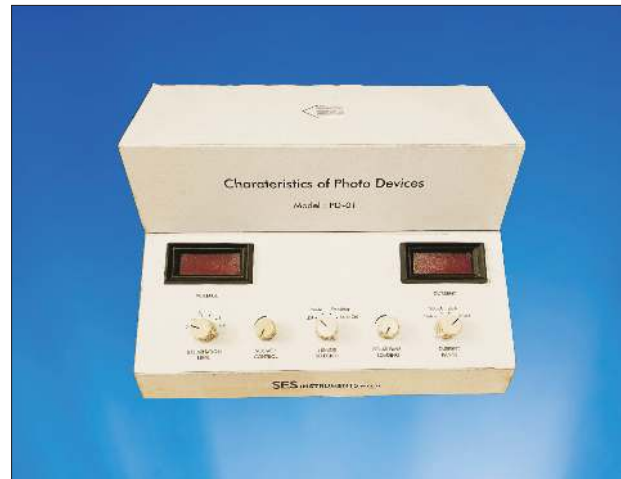

## Introduction

A transducer is a device that converts variations in a physical quantity, such as pressure, temperature, position, speed, etc., into an electrical signal or vice versa. Optical transducers, also known as photoelectric transducers, specifically convert light into an electrical quantity, such as current or voltage. They can be further classified into three types: photo emissive, photoconductive, and photovoltaic transducers.

In Study of Characteristics of Photo Devices, we present an experiment that involves studying the characteristics of four different sensors: LDR (Light Dependent Resistor), photodiode, phototransistor, and a small solar panel. These sensors are used to measure and respond to light intensity. To provide variable intensity light for the sensors, a 3W white LED is utilized as the light source.

One of the key features of the experiment is the automatic selection of circuit configurations from a panel for each chosen experiment. This eliminates the need for users to make any external connections, allowing them to focus solely on conducting the experiment. The experiment entails operating the photo devices at various light intensity levels and recording their performance characteristics. These characteristics are then subjected to detailed analysis.

By conducting this experiment, users can gain valuable insights into the behavior and performance of different optical sensors in response to varying light intensities. This information can be beneficial for various applications in fields such as electronics, automation, and measurement systems.

## Features and Specifications

- The sensors are enclosed inside a protective box located on top of the instrument, ensuring that ambient light does not interfere with the measurements. This design feature enhances the accuracy of the experiment.
- Eliminates the requirement of a dark room for conducting the experiment, providing convenience and flexibility in experimental setup.
- The lower section of the unit contains all the necessary circuits for measuring current and voltage in the experiment. Refer to photograph of the instrument above for a comprehensive panel diagram illustrating the various controls and meters used.
- Equipped with IC regulated power supplies, ensuring stable and reliable power output for the sensors and circuits.
- Includes a detailed manual providing comprehensive instructions and guidelines for conducting the experiment. The manual assists users in understanding the setup, operation, and analysis of the experiment.

# RC-01

## Study of a Transistor Amplifier (RC Coupled)

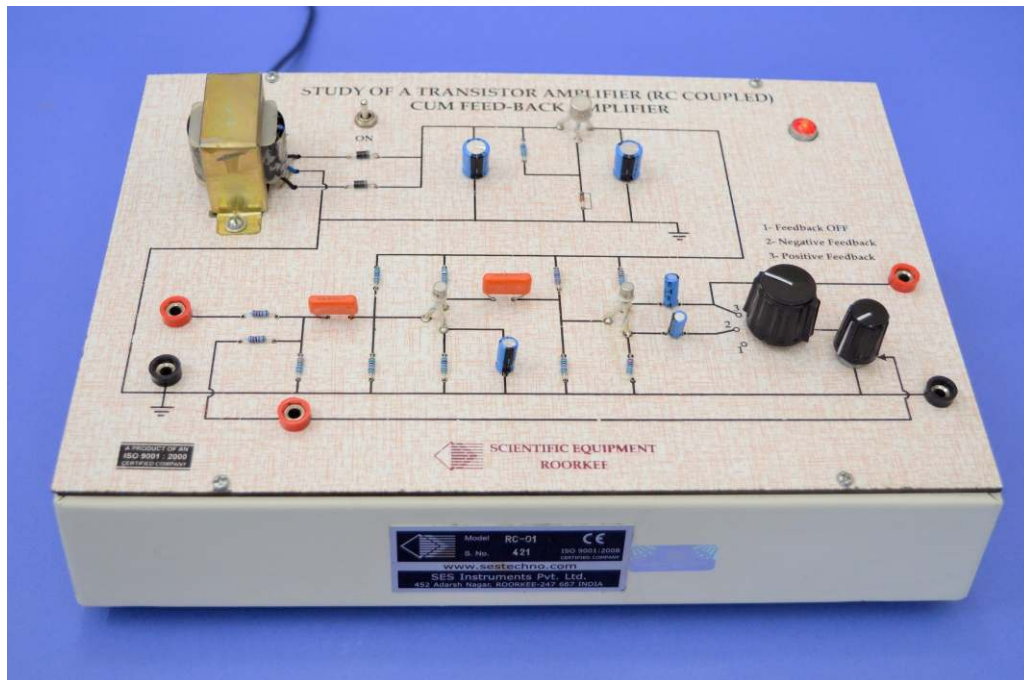

### Features

1. Study of the basic circuit of a RC coupled Amplifier
2. Frequency response of RC coupled Amplifier
3. Effect of negative feedback on the gain and frequency response of the amplifier
4. Effect of positive feedback on the gain and frequency response of the amplifier
5. Verification of the condition of oscillation
6. Study of different classes of amplifier

### Introduction

This is a two stage transistor amplifier with a provision for positive and negative feedback. The amount of feedback is adjustable and with the help of this it is even possible to make the amplifier oscillate. A 9V stabilized power is provided on the same board.

The experimental set-up has been laid down on a decorated bakelite board with an aim of providing an easy understanding to the students. All components are well spread out for clarity and easy repairs and replacement. The set-up is provided with a booklet, which contains its detailed theory of operation, description, specifications, suggestions and discussion on the various experiments that may be performed with it.

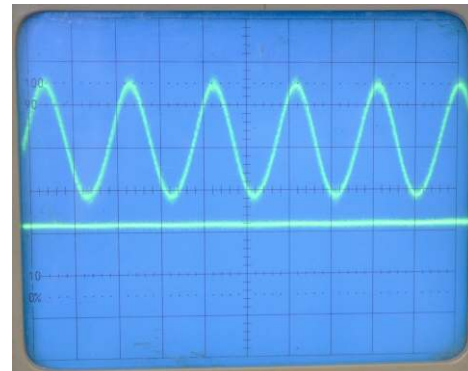
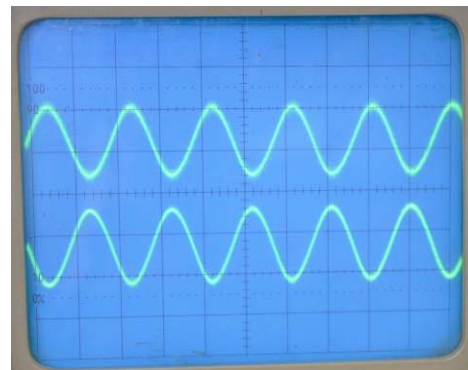

### Measuring/testing instruments required

1. A.C. Millivoltmeter (True R.M.S. A.C. Millivoltmeter, Model: ACM-102)
2. A.F. Oscillator
3. CRO

# MV-01

## Study of Multivibrators

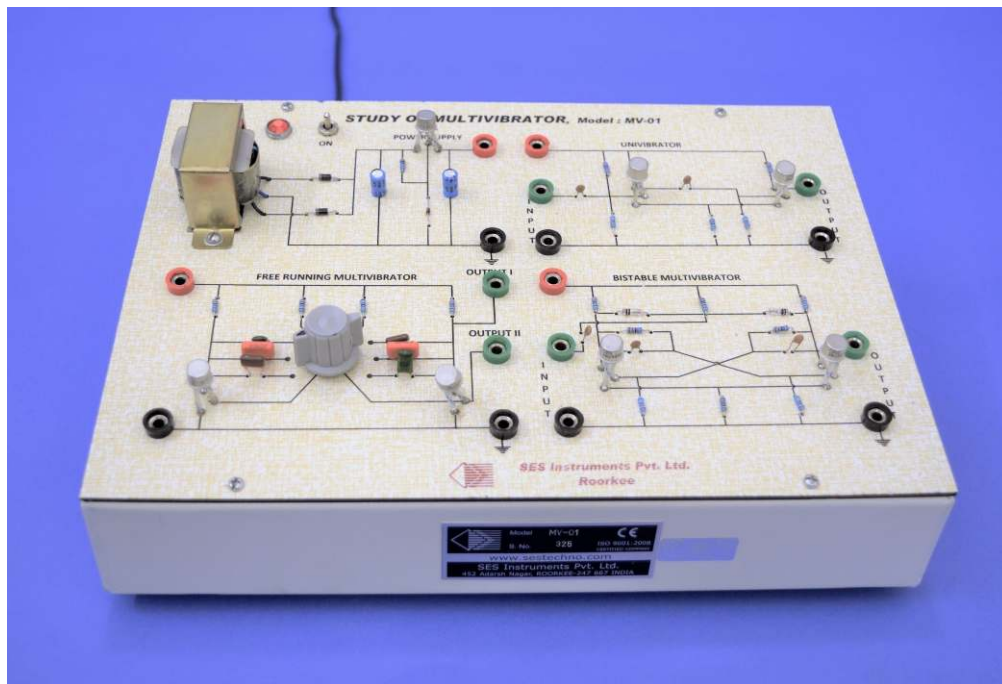

### Features

- Study of a Bistable Multivibrator.
- Study of a Free Running Multivibrator.
- Study of a Univibrator.

The free running multivibrator also serve as a pulse generator for the study of bistable multivibrator and univibrator.

### Introduction

The set-up consists of circuits of three type of multivibrators : (1) Free running multivibrator (2) Bistable multivibrator (3) Univibrator and their stabilized power supply, all mounted on a decorated bakelite board. Usual provisions for convenient inputs and outputs are provided on binding terminals.

The experimental set-up have been laid down on a decorated bakelite board with an aim of providing an easy understanding to the students. All components are well spread out for clarity and easy repairs and replacement. The set-up is provided with a booklet, which contains its detailed theory of operation, description, specifications, suggestions and discussion on the various experiments that may be performed with it.

**The unit is self contained and need no additional accessory, except an Oscilloscope.**

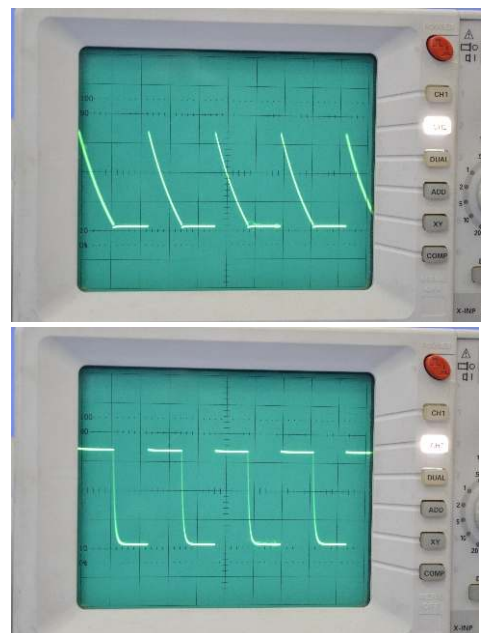

# D-1

## Characteristics of Semiconductors Diodes

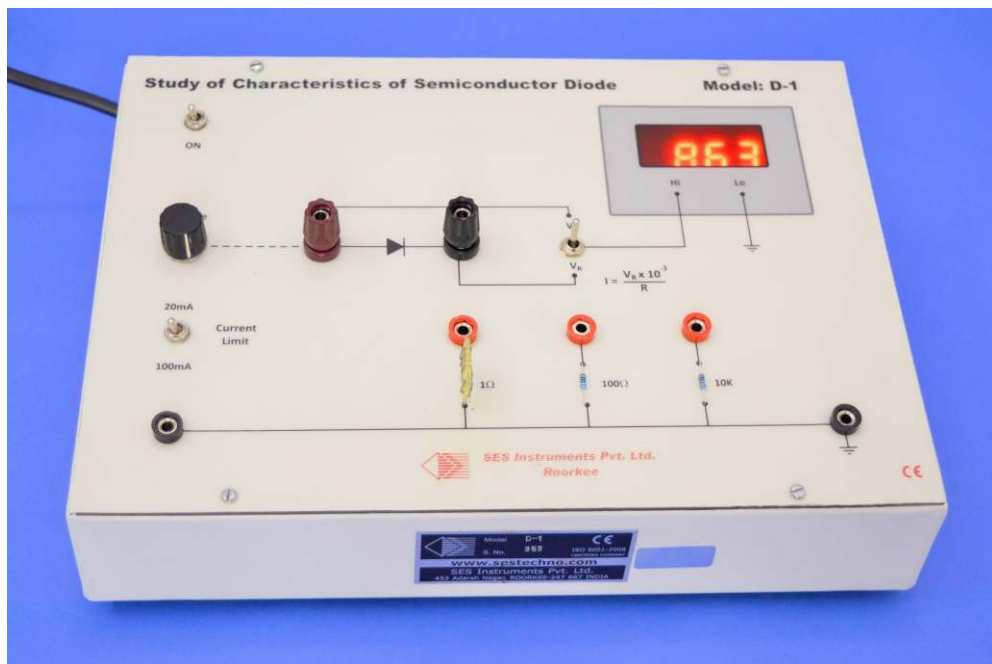

### Features

- Forward and reverse characteristics of Ge, Si diodes and LED's
- Study of Zener diode characteristics

The set-up is provided with a booklet which contains its theory of operation, description, suggestions and discussion of the experiments that may be performed with it.

### The experimental set-up consists of the following

1. Diodes: Rectifier-4007 (Si), Signal diode-1N34 (Ge), Zener 5.1V and LED
2. 3½ digit DPM which can measure voltage (0-20V)
3. Suitable precision resistances are provided for the measurement of forward current, Reverse current, in the range of 10nA to 200mA
4. IC regulated variable power supply (0-12V)

The experimental set-up is complete in all respect.

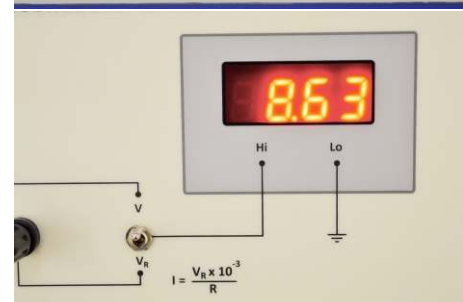

# HP-01

## Study of Hybrid Parameters of a Transistor

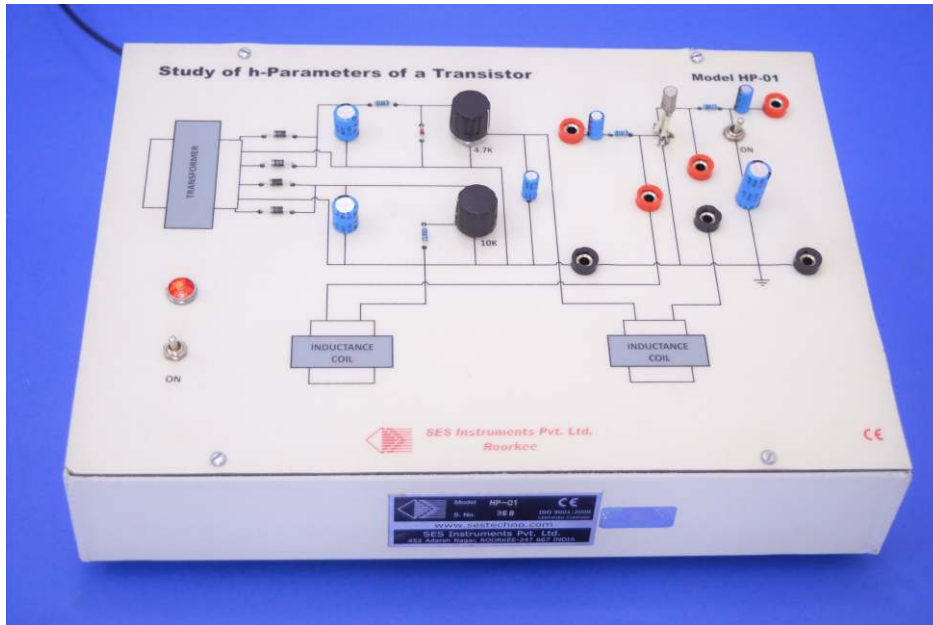

### Features

- Study of  $h_{11}$  parameter (input impedance parameter)
- Study of  $h_{22}$  parameter (output admittance parameter)
- Study of  $h_{21}$  parameter (forward current transfer ratio)
- Study of  $h_{12}$  parameter (reverse voltage feedback ratio)
- Built-in power supply

### Measuring/testing instruments required

- True R.M.S A.C. Millivoltmeter, Model ACM-103 or
- True R.M.S A.C. Millivoltmeter, Model ACM-102 & Oscillator

### Introduction

A transistor has low input impedance and high output impedance and hence the use of Z and Y parameters becomes awkward specially at high frequencies. As a result the hybrid of 'h' parameters are found to be most useful for transistor circuit analysis, because the hybrid parameters form a and high impedance of the transistor. Another advantage is that the parameters  $h_{11}$ ,  $h_{21}$  and  $h_{22}$  almost correspond to the actual operating conditions.

The experimental set-up have been laid down on a decorated bakelite board with an aim of providing an easy understanding to the students. All components are well spread out for clarity and easy repairs and replacement. The set-up is provided with a booklet, which contains its detailed theory of operation, description, specifications, suggestions and discussions on the various experiments that may be performed with it.



# SSPS-02

## Study of a Power Supply (Solid State)

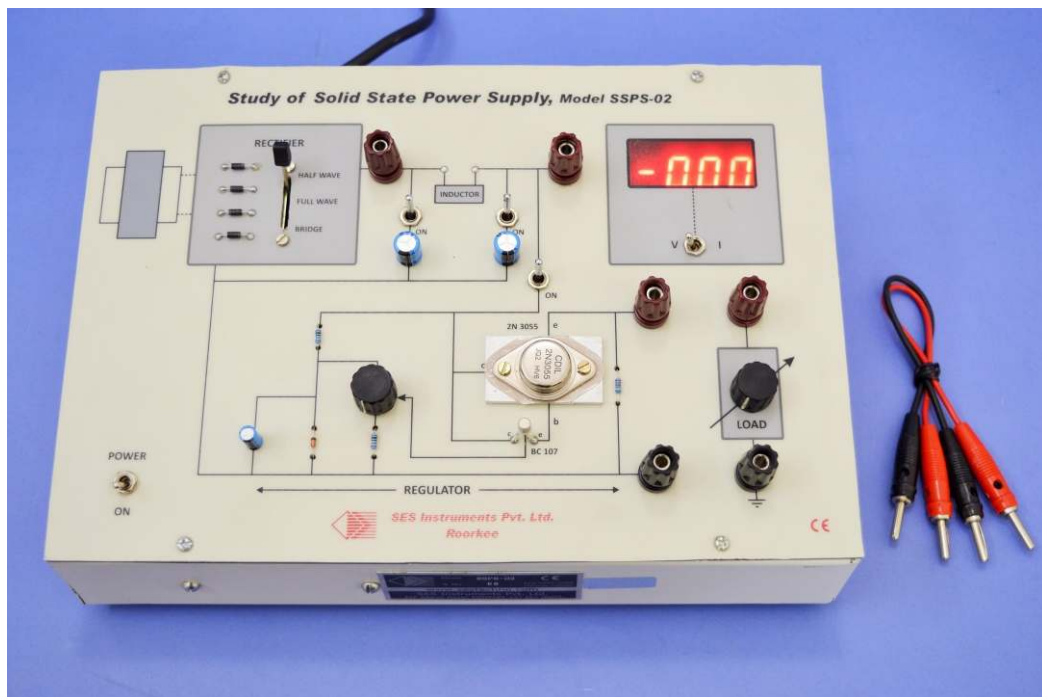

### Features

1. Study of rectification
  - (a) Full wave rectification
  - (b) Half wave rectification
  - (c) Bridge rectification
2. Study of ac component (Ripples)
  - (a) Efficiency of various type of filters L,  $\pi$ , T type etc.
  - (b) The effect of load
  - (c) The effect of regulation
3. Regulation characteristics
  - (a) The effect of load on regulation
  - (b) The effect of change in main's voltage
4. Electronic Load  
To draw the load current smoothly

### Introduction

The Set-up consists of a step-down transformer, a rectifier circuit (can be used as a half-wave or a full-wave rectifier), a filter circuit (an inductance and two capacitors) - the arrangement can be used for the study of various configuration of filters and a regulator circuit. A built-in electronic load is used to smoothly vary the load current while a digital panel meter on the board measures the load current and load voltage.

### Specifications

Output	:	0-12 volts
Max. Current	:	200 mA
Regulation	:	1%
Metering	:	Output Voltage/ Current on the switchable DPM



The experimental set-up is complete in all respect, except a Multimeter and a CRO

# MD-01

## Study of Modulation and Demodulation

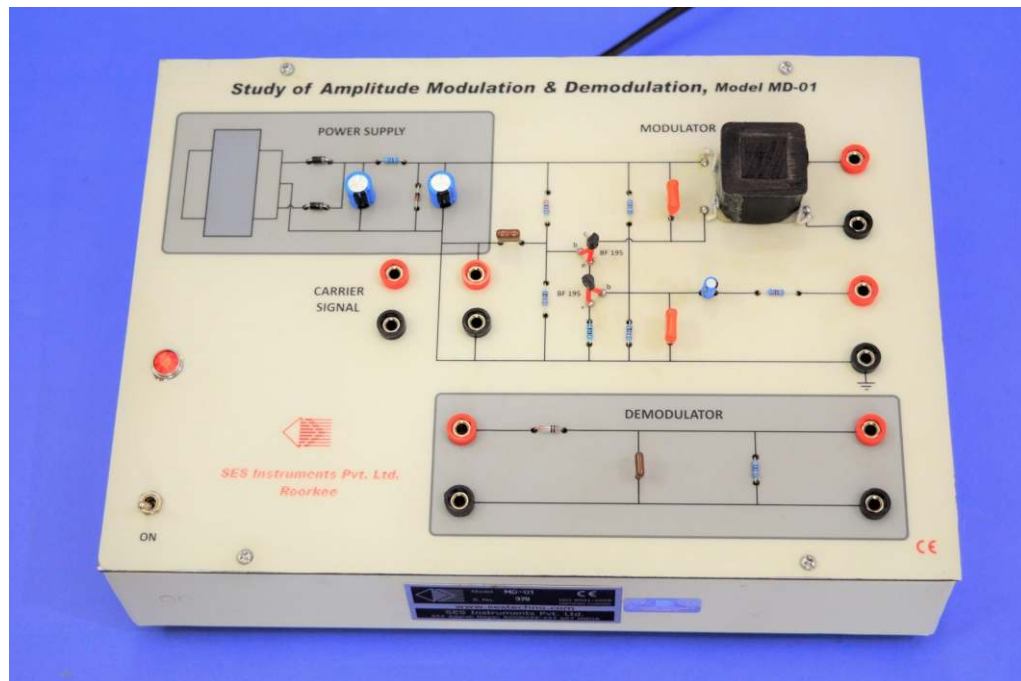

### Features

- Study of carrier signal testing.
- Study of variation of modulated wave with the modulation signal.
- Study of detector circuit.
- Built-in power supply

### Introduction

The set-up consists of modulating and demodulating circuits. It is provided with a fixed frequency (70 KHz) oscillator, which may be used for carrier frequency. This eliminates the need of an R.F. Oscillator. The carrier signal may be given from any other oscillator also if the change in carrier frequency is desired. Since the circuit is designed for comparatively low frequency (70 KHz to 150 KHz) carrier signal, the usual A.F. Frequency Oscilloscope is good enough.

The experimental set-up has been laid-down on a decorated bakelite board with an aim of providing an easy understanding to the students. All components are well spread out for clarity and easy repairs / replacement. The set-up is provided with a booklet, which contains its detailed theory of operation, description, specifications, suggestions and discussion on the various experiments that may be performed with it.

### Measuring/testing instruments required

1. A.F. Oscillator
2. CRO

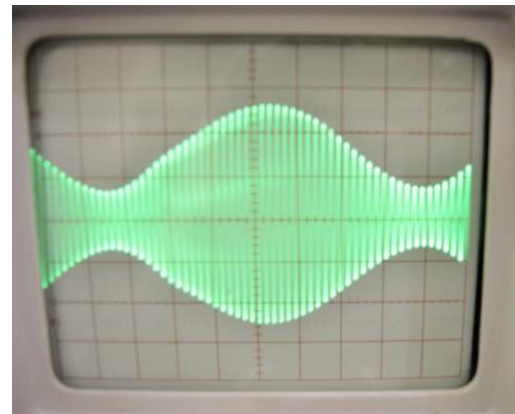

# 741-01

## Study of Basic Operational Amplifier

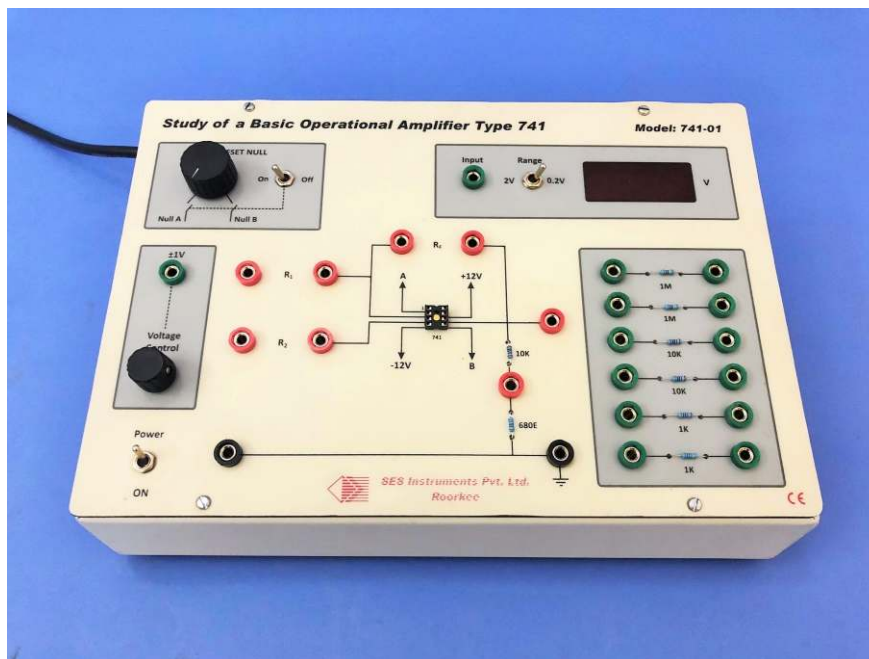

### Features

- Working of the basic circuit
- Measurement of bias currents, offset currents and offset voltage
- Study of inverting and non-inverting amplifier configurations
- Introduction to amplifier drift
- Measurement of CMRR and slew rate
- Study of frequency response (band width)
- Built-in power supply

### Introduction

The term operational amplifier (Op. Amp.) refers to high gain dc amplifier that has a differential input (two input leads) and a single ended output (one output lead). Op. Amps. have characteristics such as high input resistance, low output resistance, high gain, low drift etc., that make them highly suitable for many applications and therefore, wide spread use in electronic circuits.

The experimental set-up on the study of Op. Amp. consists of a 741 IC with facilities for convenient connections, two regulated power supplies ( $\pm 12V$ ), a variable voltage source and a multirange digital voltmeter with  $3\frac{1}{2}$  digit LED display.

The resistances (0.1% metal film) required are mounted on the board separately, which may be connected as required through patch chords. The student can also connect external components, if required.

The set-up is complete in all respect, but a A.F. oscillator would be required for frequency response.

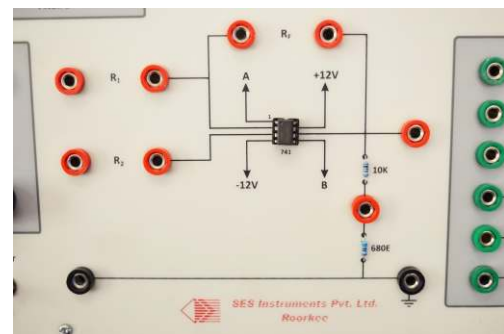

# 741-03

## Study of Operational Amplifier Application

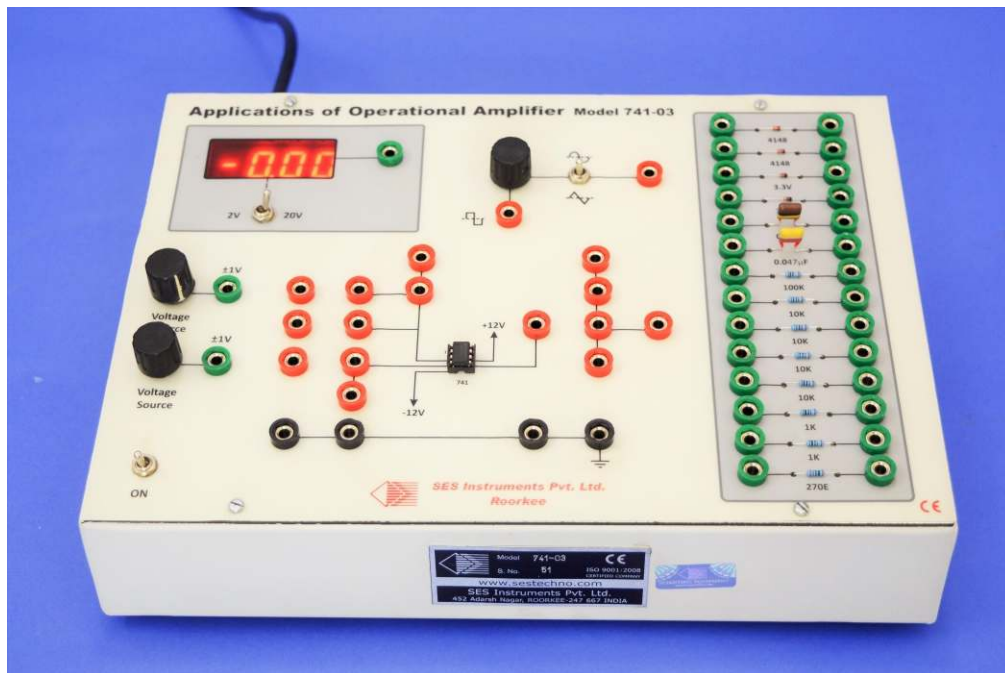

### Features

- Study of linear and non linear applications as
  - Integrator
  - V - I converter
  - Clipper
  - Differentiator
  - I - V converter
  - Clamper
  - Summer
  - Astable Multivibrator
  - Peak Detector
  - Subtractor
  - Precision rectifier
  - Schmitt Trigger
- Built-in power supply
- Built-in square wave and triangular wave Generator
- Built-in current source
- All components for the experiments suggested are available on panel

### Introduction

The operational amplifier (Op. Amp.) is a versatile device that can be used to amplify dc as well as ac input signals and was originally designed for such mathematical functions as addition, subtraction, multiplication, and integration. Thus the name operational amplifier stems from its original use for these mathematical operations. With the addition of suitable external feedback components, the modern day op-

amp can be used for a variety of applications such as Voltage to current converter, oscillator, comparators, clippers, clampers, peak detector, Schmitt trigger and others.

The experimental set-up on the study of Op. Amp. consists of a 741 IC with facilities for convenient connections, two regulated power supplies ( $\pm 12V$ ), two variable voltage source and a multirange digital voltmeter with 3½ digit LED display. The resistances (0.1% metal film), capacitances, diodes etc. as required are mounted on the board separately, which may be connected through patch chords. The student can also connect external components also, if required.

**The set-up is complete in all respect. An extra CRO would however be necessary for waveform studies.**



# 741-05

## Signal Generation Applications of Operational Amplifiers

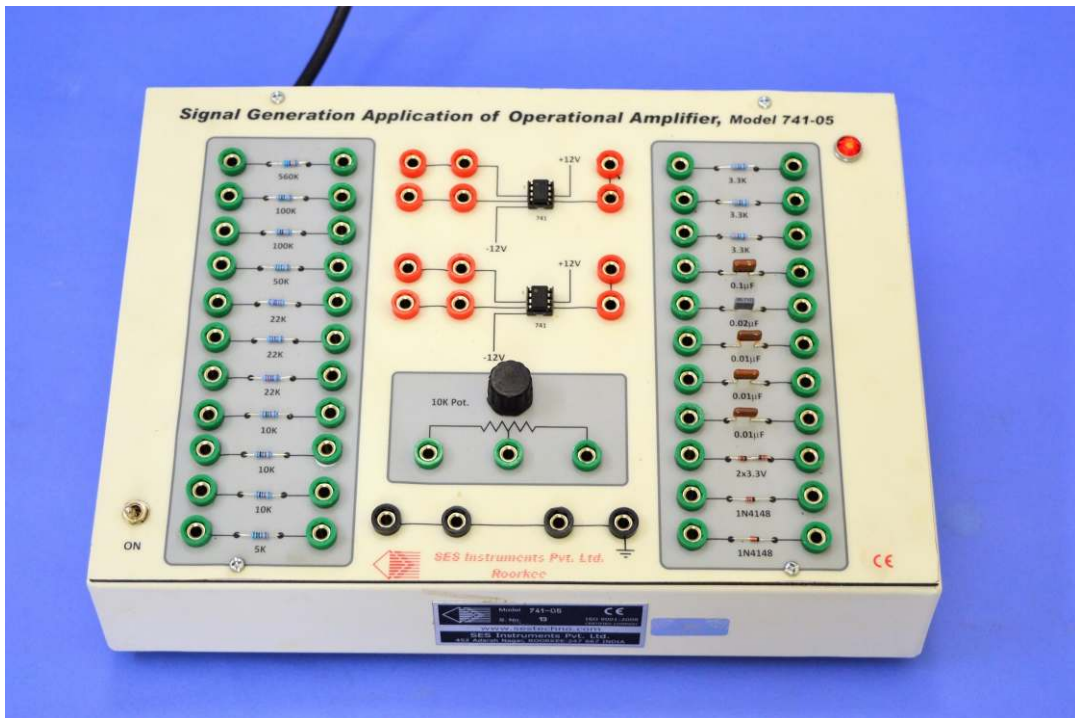

### Features

- Study of different LC oscillator circuits using operational amplifiers type-741
  - Wien-Bridge Oscillator
  - Phase Shift Oscillator
  - Twin-T Oscillator
  - Quadrature Oscillator
  - Square and Triangular Wave Oscillator
  - Sawtooth and Pulse Generator
- All necessary components are available on the panel
- Built-in power supply
- Patch cords and user manual included
- Accessory require – a dual trace oscilloscope

### Introduction

Continuous signals of various kinds form an essential block in the testing of electronic circuits. Signal generation is therefore an important task that needs to be introduced to a student of electronics at an early stage. Particularly important are the medium to low frequency signals that are used so commonly. The present unit is designed to explore the operational amplifier based resistance-capacitor type signal generation circuits of various kinds in the lower kHz region. Besides sinusoidal signals, the study covers square wave, triangular wave, sawtooth and sharp pulse generation. The

description begins with the basic theory of oscillations, viz., the Barkhausen criterion, and discusses various oscillator circuits and their mode of working. Apart from the configurations suggested, additional circuits too may be attempted by the user.

The experimental board comprises of two operational amplifiers and some 24 passive components carefully arranged on it. While the amplifiers are pre-wired with internal power supply, the other components need to be suitably connected using the patch cords provided. Only a dual trace oscilloscope would be required as an accessory. The user manual supplied with the unit covers all technical details for conducting the experiments. References are cited for additional information.



# 741-07

## Study of OP AMP based LC Oscillators

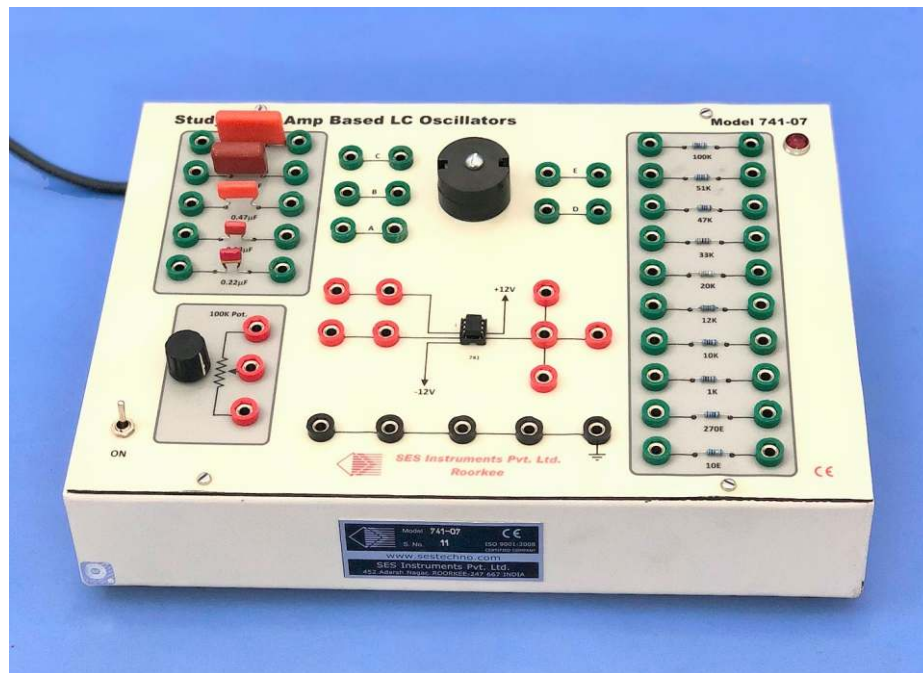

### Features

- Study of different LC oscillator circuits using operational amplifiers type-741
  - Hartley Oscillator
  - Tuned Output Oscillator
  - Colpitts Oscillator
  - Clapps Oscillator
- All necessary components are available on the panel
- Built-in power supply
- Patch cords and user manual included
- Accessory require – a dual trace oscilloscope

component variation by the user and study their effects. The user manual covers a description of the basic theory of oscillations, viz., the Barkhausen criterion, and discusses various oscillator circuits and their mode of working. Of special interest are the mechanism of amplitude stabilization and the loop phase.

The experimental board comprises of an operational amplifiers and some 17 passive components carefully arranged on it to be suitably connected with patchcords. Only a dual trace oscilloscope would be required as an accessory. The user manual supplied with the unit covers all technical details for conducting the experiments.

### Introduction

Sine wave signals at different frequencies find application in the frequency response studies of various electronic circuits and systems. Historically these sine wave signals have been generated using LC tuned circuits and RC circuits, although digitally synthesized signals are now becoming more common. Basic signal generation is therefore an important task that needs to be introduced to a student of electronics at an early stage. Particularly important are the medium to low frequency signals in the audio ranges. Our experimental unit type 741-05 covers RC oscillators while the present unit is designed to explore the operational amplifier based inductance-capacitor type circuits of various kinds in the lower kHz region. The unit has the possibility of a range of



# AF-01

## Study of Active Filters

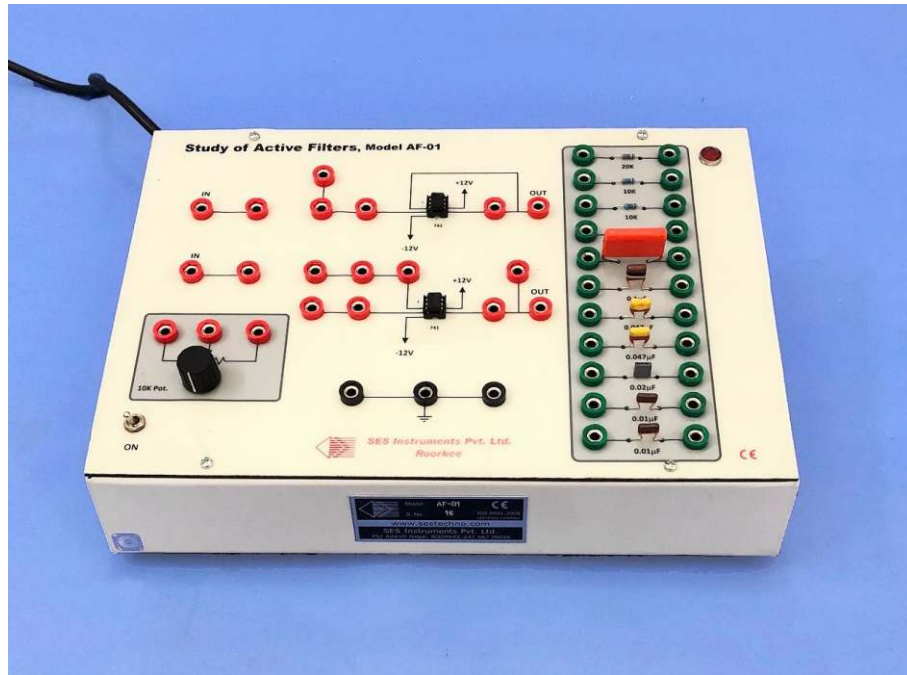

### Features

- Frequency response studies of various active filter circuits using operational amplifiers type-741
  - Lead/Lag compensator
  - Low/High pass filter
  - Band Pass/Band Reject filters
  - All pass filter
  - Twin-T (Notch) filter
  - Adjustable Q Notch filter
- All necessary components are available on the panel
- Built-in power supply
- Patch cords and detailed user manual included
- Accessory required– (i) Function Generator (ii) Dual trace oscilloscope

### Introduction

Filters are circuits which have a varied response to different frequencies and are primarily used in applications where one intends to boost or suppress some frequencies. There is naturally a very large number of filter circuits that are in use. The aim here is to suggest a few basic filters that may be constructed using the components available on the experimental board and then determine their frequency response (Bode diagram). The experimental board comprises of two operational amplifiers and some 17 passive components carefully arranged on it to be suitably connected with patchcords. A function generator and a dual trace

oscilloscope would be required as an accessory for determination of the magnitude and the phase responses. The user manual supplied with the unit covers all technical details for conducting the experiments however it is recommended that the reader goes through a theoretical analysis of the circuits from available literature and note the significant performance characteristics of each filter that may then be verified.



Although any sine wave source may be used for the experiment, we recommend a DDS dual channel function generator Type JDS 6600 which greatly simplifies the measurements.

# 555

## Study of Astable & Monostable Multivibrators

### Study Of Astable & Monostable Multivibrators Using Timer Ic: 555

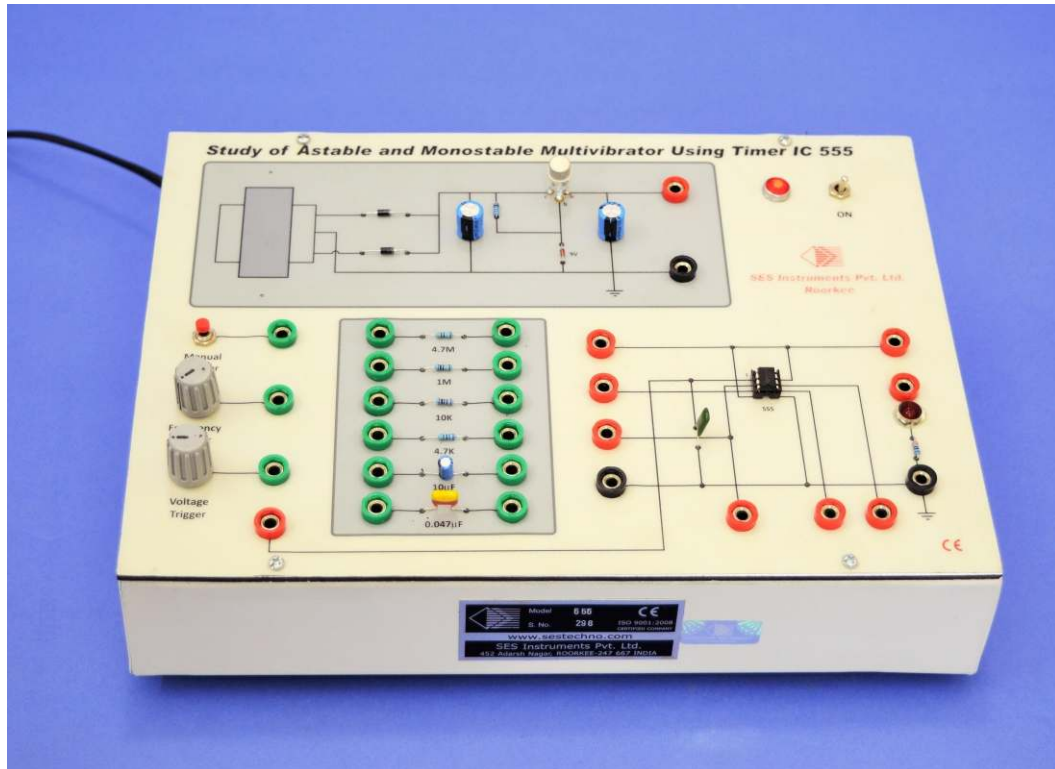

#### Features

- Operation as a free running/ astable multivibrator
- Operation as a monostable multivibrator
- Operation as a preset time delay

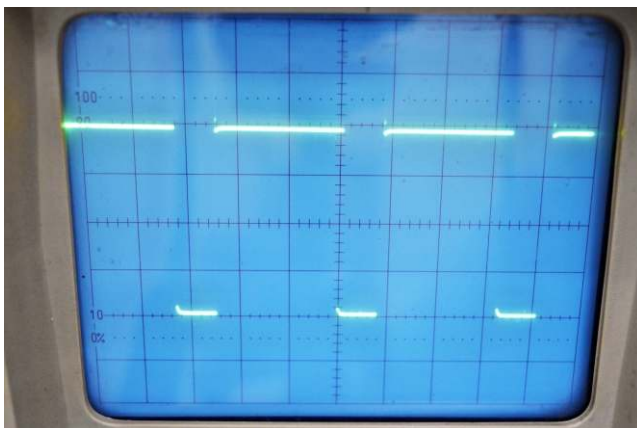

#### Introduction

555 timer is a highly stable integrated circuit capable of functioning as an accurate time-delay generator and as an astable multivibrator or free running multivibrator. When used as an oscillator the frequency and duty cycle are accurately controlled by only two external resistors and a capacitor. Some of its important features are timing from micro-seconds through hours, monostable and astable operation, trigger and reset inputs are logic compatible, and output compatible with CMOS, DTL and TTL (when used with 5V supply).

The set-up consists of 555 IC with facilities for convenient connection at the board, a power supply, built-in facilities for various type of triggers-variable frequency, variable voltage, and manual. The resistors and capacitors required are mounted on the board.

The set-up is complete in all respect, including patch chords

## Study of An Integrated Circuit Regulator

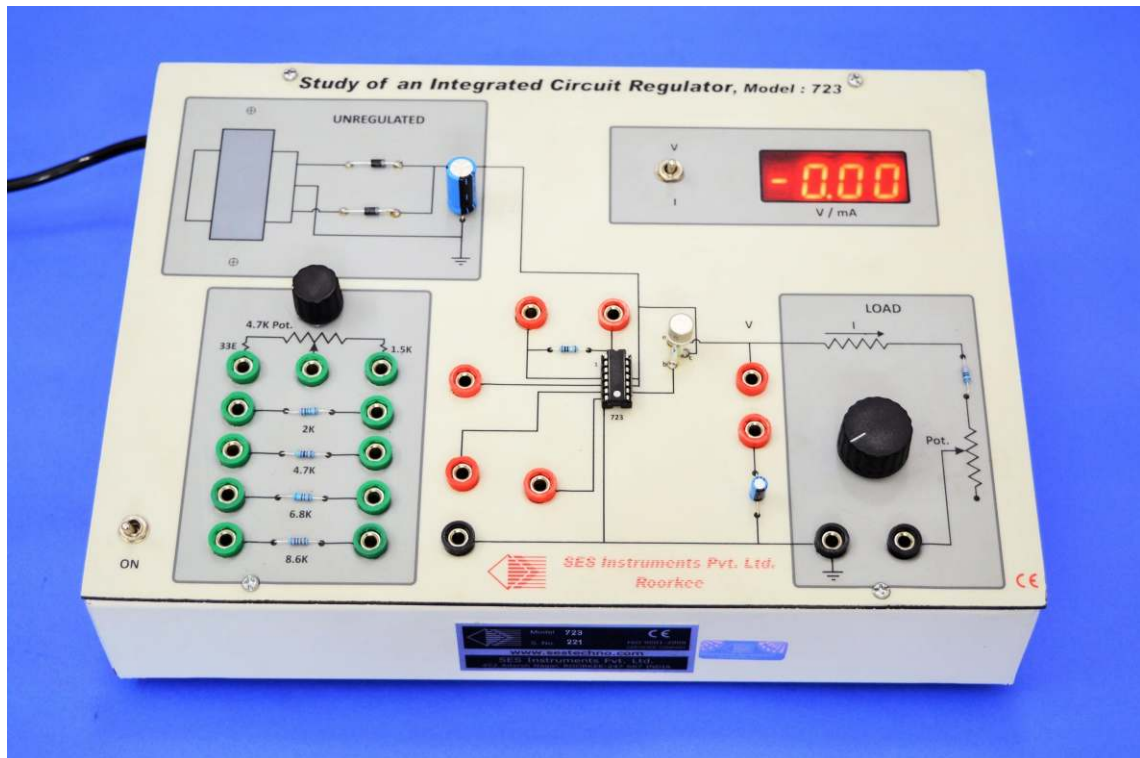

## Features

- Study of 723, working as a voltage regulator
- Study of 723, working as a current regulator

## Introduction

The 723 is a monolithic precision voltage regulator constructed on a single silicon chip. The device consists of a temperature compensated reference, error amplifier, power series pass transistor and current limit circuitry. Some of its important features - adjustable output voltage from 2 to 37V, of either polarity, 0.01% line and 0.03% load regulation, output current upto 150mA without external pass transistor make it a general purpose IC for voltage or current regulation.

The experimental set-up consists of an IC 723 with facilities for convenient connections, an unregulated power supply, voltmeter, an ammeter and all the other components - resistances, potentiometers, variable load etc. required to perform the experiments.

The set-up is complete in all respect including patch cords.



# VSM-1000

## Vibrating Sample Magnetometer



### VSM Measurement System/ Magnetic Measurement Instrumentation

- High sensitivity (Resolution better than  $10^{-4}$  emu)
- Four Measuring Ranges ( $10^2$ , 10, 1,  $10^{-1}$ )
- Low noise and highly stable system
- High speed measurements with precision
- Menu driven easy to use software
- Easy change of sample
- Water cooled electromagnet for increased stability

The SES Vibrating Sample Magnetometer (VSM) measures the magnetization of a sample of magnetic material under an external magnetic field by converting the dipole field of the sample into an ac electrical signal. A vibrator along with its electronics vibrates the sample with a fixed frequency and stabilized amplitude. The sample is driven to vibrate. Due to changes in flux, voltage proportional to the sample's magnetic moment is induced in the pickup coils. By calibrating this voltage to magnetic moment using calibration standards and measuring the magnetic field, the magnetic moment of the sample can be obtained. The software controls the instrument and measures the magnetic moment. Hysteresis Loop can also be drawn through this software and its parameters calculated.

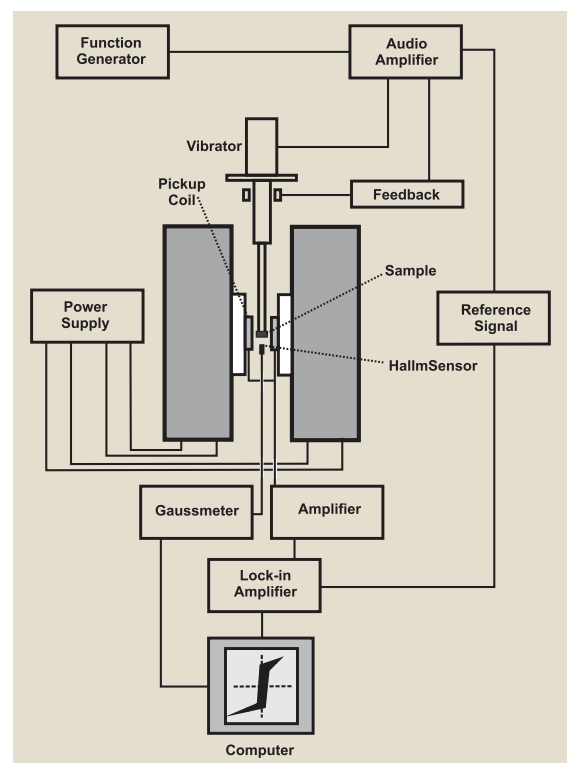

# VSM-1000

## Vibrating Sample Magnetometer

### System Description

#### 1. Magnetic Field System

- a. Electromagnet (Magnetic field is higher than 0.5T at gap of 25mm in iron cores)
- b. Power Supply
- c. Gauss Meter (Range: 20kGauss to 1Gauss )
- d. Embedded Magnetic Flux Detector

#### 2. Control System

- a. Built-in computer systems (with Microsoft Windows)
- b. Built-in Software Interface for Collecting and Analyzing Data "

(Hysteresis loops can be measured automatically to find the saturation, magnetization, coercivity and remanence of magnetic samples.)

- c. Built-in Data Acquisition System

#### 3. Others

- a. Standard Computer with i-core 3 processor and original Windows10 loaded.
- b. Keyboard and Mouse
- c. Calibrations standard samples (99.9% Nickel and HgCo (SCN<sub>4</sub>))

#### 4. Test Results

The different test samples

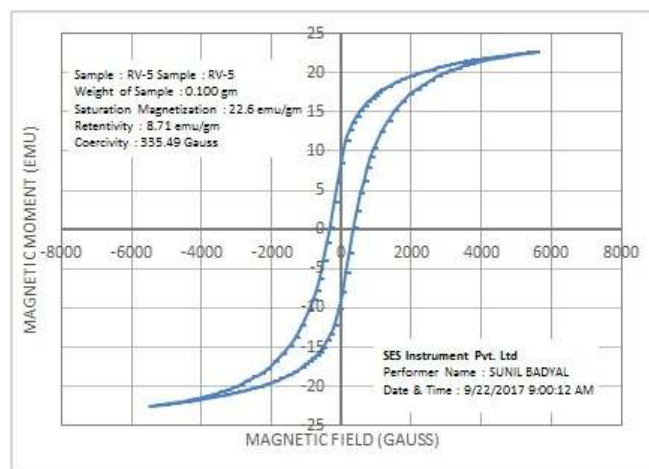
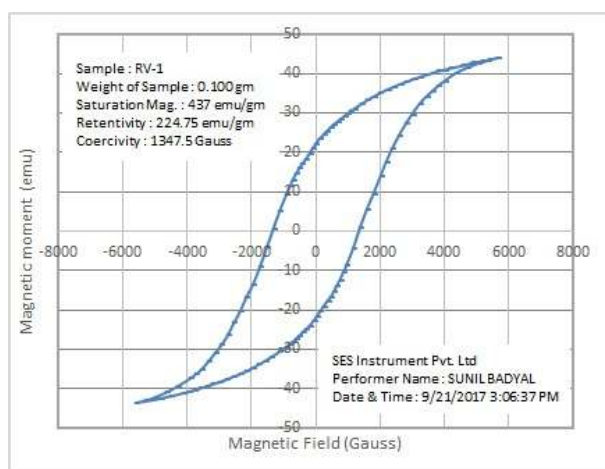
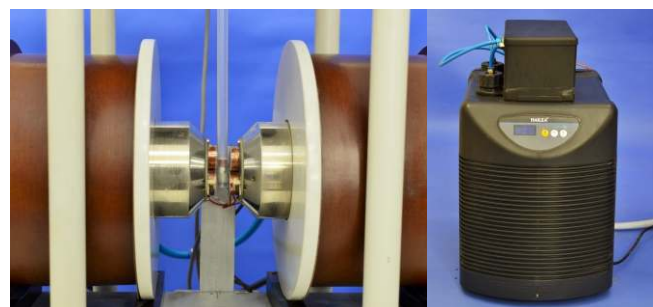
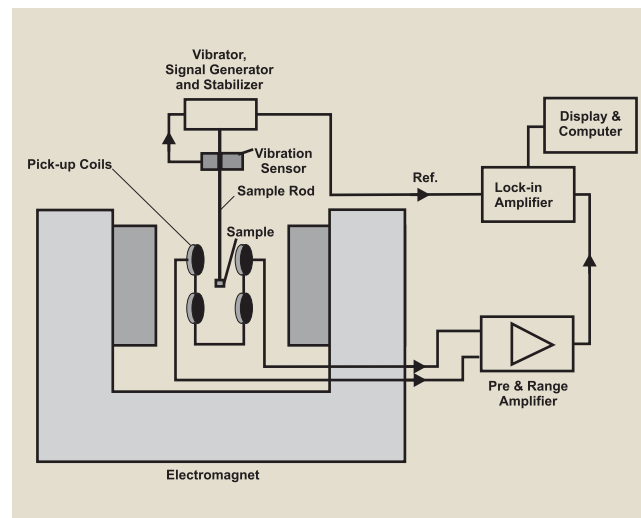

# Our Team Leaders

Ravi Prakash, Managing Director



Ravi Prakash joined SES Instruments Pvt Ltd. after completing his M.Tech. from IIT Roorkee in 1994. Working under his father, Dr. Anand Prakash, then Managing Director of the company he brought various innovative ideas and was successful in expanding the reach of the company in more than 30 countries. The sales and operations expanded by more than 600% in the last 15 years. A quality culture was developed with less than 0.01% product return rate and less than 0.5% warranty support requirement. He led the company in achieving CE and ISO certification. Appointed as Managing Director in 2009, he focused the company efforts towards R&D helping the company launch more than 8 new products. Expanding the production facility and sales network saw a consistent growth of more than 40% per year.

Dr. R. Mitra, R&D Director

Dr. Mitra obtained his Ph.D. from the University of Roorkee (now IIT Roorkee) in the year 1976. The area of his specialization was Control Systems. His earlier education was from IIT Kharagpur, University of Allahabad and University of Lucknow. Besides post-doctoral work at DFVLR in West Germany, he had been in the faculty of University of Technology, Baghdad and Thapar Institute of Engineering and Technology, Patiala. Since 1970 Dr. Mitra is with the Department of Electronics & Computer Engineering, IIT Roorkee, actively involved in teaching and research in the areas of control systems, electronics, microprocessors and electronic instrumentation. After his retirement he is continuing in the department as an emeritus professor. Association with him for more than 42 years has helped us to develop and bring to perfection most of the experiments listed in this catalog. Besides, our diversification to the area of control system, leading to a dozen experiments, has been solely due to his continuous efforts and support.



Dr. Kailash Chandra, Director Technical



Dr. Kailash Chandra did his M.Sc (Physics) in 1962, Ph.D in 1968 from the University of Roorkee( now IIT-Roorkee) and postdoc at Uppsala University Sweden. His research area was Mossbauer spectroscopy where he himself developed the laboratory from scratch and brought to International level. He joined the faculty of Physics at University of Roorkee in 1967 and rose to Professor and Director in 1980 at University Science Instrumentation Centre (USIC) of University of Roorkee. His main interest has always been experimental Physics and Instrumentation. Towards the later part of his active service he started working in Nanoscience and technology and published more than a dozen research papers. His associations with us have proved very vital in the development of many new equipment and experiments.

**Control Laboratory, Instrumentation Lab, Measurement Lab Experiments are also available**

For further details contact our sister concern

**TECHNO INSTRUMENTS**



**SES** INSTRUMENTS PVT. LTD.

452 Adarsh Nagar  
Roorkee-247667  
India